

UIPCM UNIVERSAL INPUT TO PULSE CONVERTER MODULE

FEATURES

- ❖ Optional feedback input for closed loop control
- ❖ Jumper selectable analog input
- ❖ DIP switch selectable input/output pulse types
- ❖ Open collector or 24VAC Triac output available

APPLICATIONS

- ❖ 0 - 20 mA to tri-state floating or PWM
- ❖ 0 - 10V DC to tri-state floating or PWM
- ❖ PWM to tri-state floating
- ❖ Tri-state floating to PWM
- ❖ Phase cut to tri-state floating or PWM

DESCRIPTION

The UIPCM accepts all standard analog input signals, including phase cut, as well as digital pulse width modulated (PWM) and tri-state floating inputs and converts them to a PWM or tri-state floating output. The UIPCM is useful when interfacing to floating input damper actuators, or PWM input devices. It uses state of the art micro controller technology that give it superior control system performance. The universal input allows for a quick and simple solution for virtually all applications. The UIPCM can be user reconfigured when a field change is required. The outputs may be factory configured for either an AC Triac switched output or an open collector DC output.

OPERATION

Two half-wave, filtered, and regulated supplies provide power to the on-board circuitry. The UIPCM uses an embedded micro controller. The micro controller interprets the input signals and provides a corresponding output signal. The analog input may be configured to accept 0- 5V DC, 0-10V DC or 0 to 20mA by making a jumper selection. The pulse inputs will accept pulse width modulated, or tri-state floating signals at time bases of 2.5, 10, 60, and 120 seconds.

The PWM input may also be configured to accept a 10 to 90% phase cut input with a jumper and DIP switch selection. DIP switch settings also select pulse input and output types and time bases. An external feed back input is available for closed loop control. The feed back input is configured for 0-10V DC, however, custom feed back configurations are available upon request. ZERO and SPAN adjustments are available for adjustments to input signals or for sequencing or rescaling applications. The ZERO and SPAN adjustment instructions can be found in the Field Setup and Calibrations.

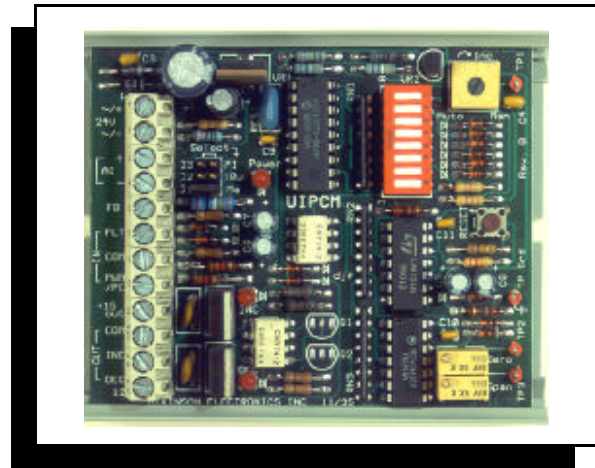

SPECIFICATIONS

SIZE:	4.5" L x 3" W x 1.25" H
MOUNTING:	3" RDI snap-track (supplied)
POWER:	24V AC, ± 10%, 50/60Hz, 2VA
INPUTS:	10 - 90% Phase Cut 0 - 20 mA, 0-5V DC, 0-10V DC PWM or 3 Point Floating @ 2.5, 10, 60 and 120 seconds
FEEDBACK SIGNALS:	STD. 0-10V DC, OPT. 0-5V
OUTPUTS:	PWM or Tri-state @ 2.5, 10, 60 and 120 seconds
OUTPUT RATINGS:	24V AC Triac @ 4Amps Open Collector @ .5Amps
ADJUSTMENTS:	ZERO - 256 step absolute SPAN - 64 step 1/3x to 3x
AMBIENT TEMP:	0 to 85°C

WIRING CONFIGURATION

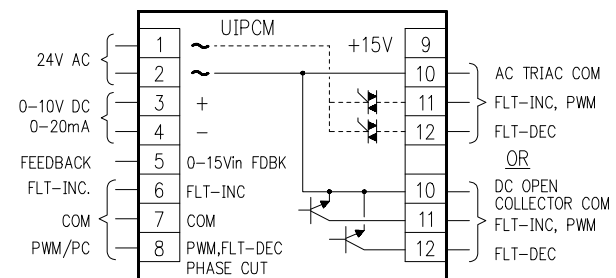

ORDERING INFORMATION

UIPCM/SEL/XX/XX

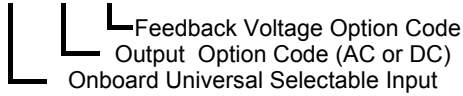

ONBOARD UNIVERSAL SELECTABLE INPUT

- PC - 10-90% Staefa Phase Cut
- mA - 0-20mA input (JP1)
- 5V - 0-5V DC input (JP3)
- 10V - 0-10V DC input (JP2)
- PWM - Pulse Width Modulation input
- FLT - 3 Point Floating (Tri-State) input

OUTPUT CODE OPTIONS

- AC - 24 V AC digital Triac output
- DC - 15 V DC digital open collector output

FEEDBACK VOLTAGE CODE OPTIONS

- 5V - 0 to 5 V DC feedback input signal
- 10V - 0 to 10 V DC feedback input signal (STD)
- 15V - 0 to 15 V DC feedback input signal

ORDERING CODE EXAMPLES

- UIPCM //AC - Universal input to 24V AC tri-state floating or PWM output.
- UIPCM //DC - Universal input to 15V DC tri-state floating or PWM output.

TYPICAL APPLICATIONS

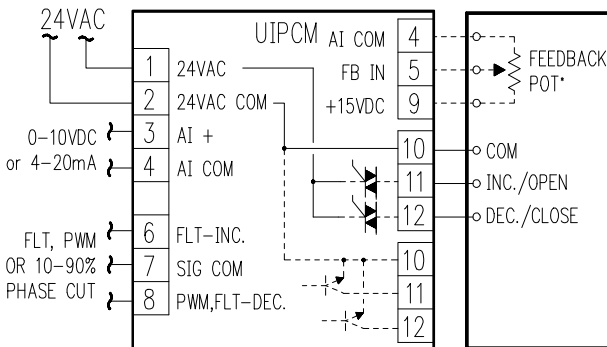

The UIPCM-AC uses two logic triacs to switch the 24V AC outputs. The UIPCM can be configured with an optional feedback input for open or closed loop control.

Call for other calibration ranges and versions.

PHYSICAL CONFIGURATION

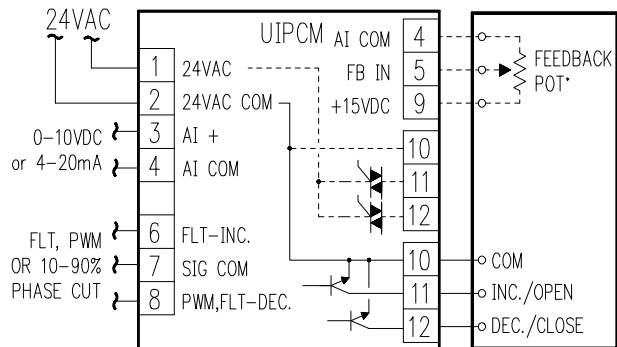
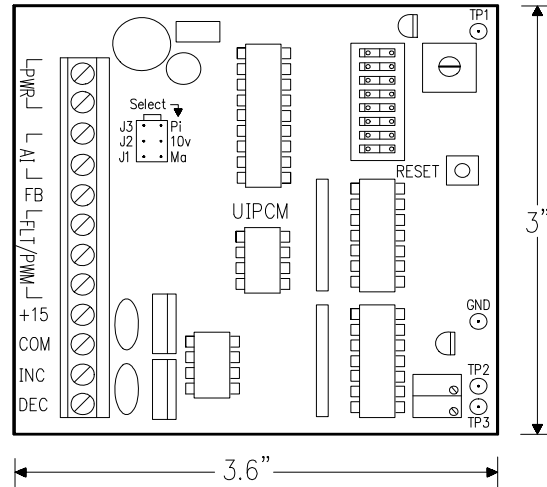

The UIPCM-DC uses two open collector NPN transistors to switch the common in and out, in either PWM or tri-state floating applications.