

Description

The Model 1060 is a three-wire microprocessor-based signal transmitter for use with the strain gage Target inline, insertion or sanitary flowmeters. The Model 1060 standard outputs are a 4-20 mA analog and 0-1000 Hz digital output signals that are proportional to flow rate. RS 232 serial communications allow communication between the Model 1060 and a PC. The Model 1060 can be integrally mounted or remote mounted up to 100 ft.

Technical Information

Functional Specifications

Ambient Temperature	32° to 140°F (0° to 60°C)
Power Input	16 to 30 VDC (3 - wire)
Load Input Impedance	600 ohm @ 24 VDC supply/400 ohm @ 12 VDC supply
Outputs	4-20 mA DC isolated 4 mA represents zero flow and 20 mA is full scale flow 0-1000 Hz square wave 50% duty cycle 12 VDC output proportional to flow rate
Communications	RS 232
Display	None
Low Flow Cutoff	Factory set based on flowmeter turndown
Response Time	0.1 sec std. undamped

Performance Specifications

Accuracy	0.02% of rate
Repeatability	0.01% of rate
Enclosure Protection	NEMA 4X/IP 66
Enclosure Approvals	FM, CSA Class I, Groups B,C,D Class II, Groups E, F,G EEx d IIC

Physical Specifications

Materials of Construction	
Case	Polyester coated aluminum
Electrical Connection	3/4" FNPT

Dimensions (inch)

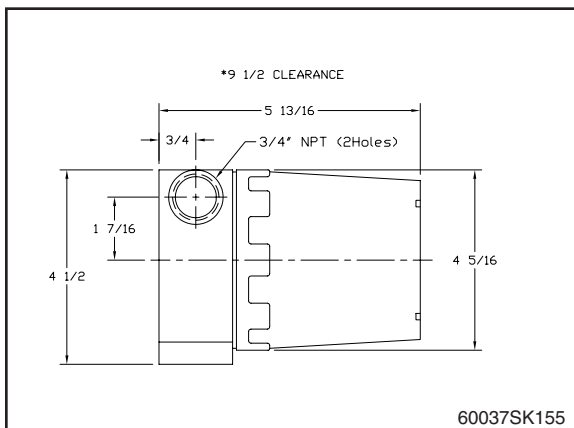

Figure 1

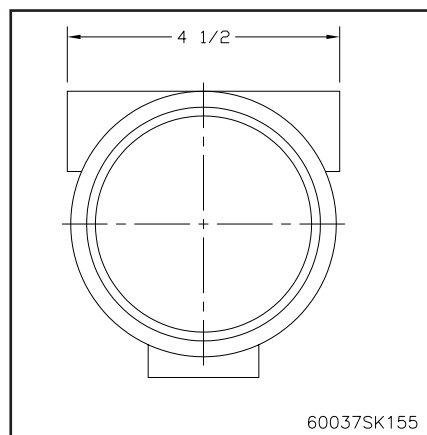

Figure 2

Ordering Information

Specify model number, remote or integral mounting and type of output at the time of ordering.