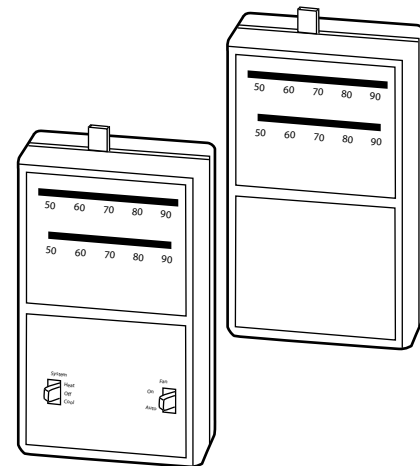

**Non-Digital, On/Off Thermostat  
General Instructions****Application**

The 31-102 model thermostats control heating or cooling applications which require a single pole/double throw (SPDT) system switch, adjustable heat anticipator and fixed cooling anticipator.

The 31-103 model thermostats control heating and cooling applications with adjustable heat anticipator and fixed cooling anticipator. Includes a "Heat-Off-Cool" system switch and "On-Auto" fan switch.

**31-102 & 31-103 Series****Features**

- A bi-metal activated mercury bulb is used as the switching mechanism
- Mounted directly on wall or standard outlet box with thermometer
- Adjustable heat anticipator
- Fahrenheit and Celsius models

# SPECIFICATIONS

## Inputs

**Power Input:** 24 to 30 Vac, 1.0 amp.  
**Heat Anticipator:** 24 Vac, 0.3 to 1.2 amps.  
**Cool Anticipator:** 5°K

## Outputs

**Mechanical:**  
**Setpoint Adjustment Range,** 50 to 90°F (10 to 32°C).  
**Setpoint Differential,** 2°F.

## Environment

**Temperature Limits:**  
**Shipping & Storage,** 0 to 120°F (18 to 4°C).  
**Operating,** 32 to 110°F (0 to 43°C).  
**Humidity:** 95% RH non-condensing.  
**Location:** NEMA Type 1.

Table-1 Model Chart.

Model	Description
31-102	Standard low voltage thermostat in Fahrenheit.
31-103	"Heat-Off-Cool" system switch and "On-Auto" fan switch in Fahrenheit.

## TYPICAL APPLICATION (wiring diagram)

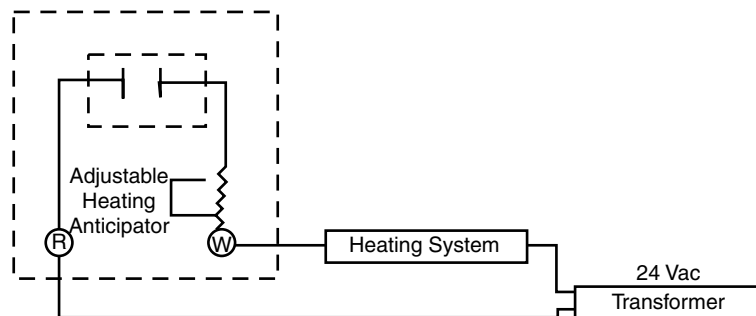

Figure-1 Typical Application for Heating Thermostat 31-102 (No System or Fan Switches).

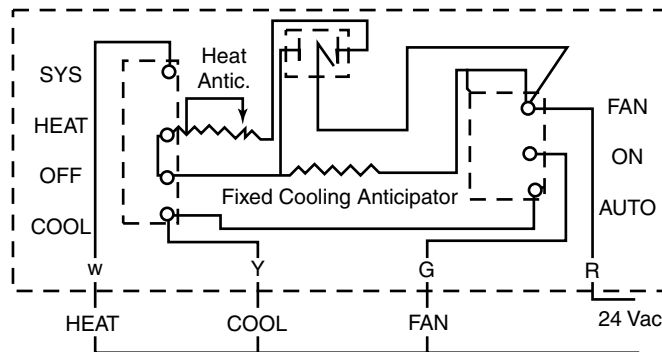

Figure-2 Typical Application for Heating/Cooling Thermostat 31-103 (System: Heat-Off-Cool; Fan: On-Auto).

# INSTALLATION

## Inspection

Inspect the package for damage. If damaged, notify the appropriate carrier immediately. If undamaged, open the package and inspect the device for obvious damage. Return damaged products.

## Requirements

- Tools (not provided)
  - Level
  - Screwdriver
  - Digital multimeter
- Training: Installer must be a qualified, experienced technician
- Other accessories as appropriate

## Precautions

### General

#### ▼ **WARNING**

---

- Electrical shock hazard! Disconnect power before installation to prevent electrical shock or equipment damage.
  - Make all connections in accordance with the electrical wiring diagram and in accordance with national and local electrical codes.
- 

#### ▼ **CAUTION**

---

- Avoid locations where excessive moisture, corrosive fumes, explosive vapors, or vibration are present.
  - Avoid electrical noise interference. Do not install near large conductors, electrical machinery, or welding equipment.
- 

### Federal Communications Commission (FCC)

#### **NOTE**

---

This equipment has been tested and found to comply with the limits for a Class B digital device, pursuant to Part 15 of the FCC Rules. These limits are designed to provide reasonable protection against harmful interference in residential installations. This equipment generates, uses, and can radiate radio frequency energy and may cause harmful interference if not installed and used in accordance with the instructions. Even when instructions are followed, there is no guarantee that interference will not occur in a particular installation. If this equipment causes harmful interference to radio and television reception—which can be determined by turning the equipment off and on—the user is encouraged to try to correct the interference by one or more of the following measures:

- Reorient or relocate the receiving antenna.
  - Increase the separation between the equipment and receiver.
  - Connect the equipment to an outlet on a circuit different from that to which the receiver is connected.
  - Consult the dealer or an experienced radio/television technician for help.
- 

### Canadian Department of Communications (DOC)

#### **NOTE**

---

This class B digital apparatus meets all requirements of the Canadian Interference-Causing Equipment Regulations.

Cet appareil numérique de la classe B respecte toutes les exigences du Règlement sur le matériel brouilleur du Canada.

### European Standard EN 55022

#### ▼ **WARNING**

---

This is a class B (European Classification) product. In a domestic environment this product may cause radio interference in which case the user may be required to take adequate measures.

---

## Mounting

1. Remove the cover of the thermostat by pulling gently at the top or bottom away from base.
2. Disconnect the power supply.
3. Locate the thermostat approximately five feet above the floor level.
4. Level the thermostat and attach to wall.

---

**NOTE**

Do not install where anything can obstruct the air flow around thermostat. Avoid external heat sources.

---

5. Connect electrical wires to the terminal screws.

---

**NOTE**

Wiring must not interfere with the operation of the thermostat.

---

6. Recheck to insure that the thermostat is level.

## Wiring

See Figure-1 and Figure-2 for typical wiring applications.

### Heat Anticipator

The heat anticipator is an adjustable resistor which preheats the thermostat bimetal as the space temperature approaches set point. This helps prevent overshoot or exceeding the set point.

Set adjustable heat anticipator to match the current draw in the heat circuit. For shorter "On" times move the heat anticipator pointer clockwise. Do not move more than two divisions from initial setting when setting for shorter "On" times. For longer "On" times move heat anticipator pointer counter clockwise.

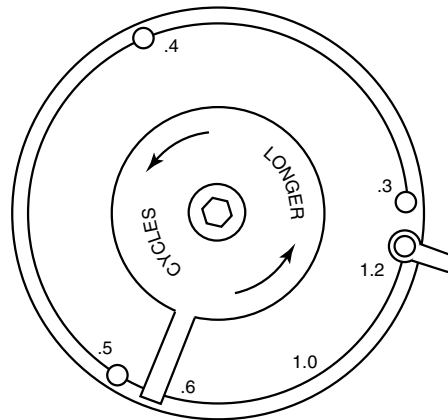

Figure-3 Heat Anticipator.

---

**NOTE**

The cooling anticipator is fixed at 5 K ohms. The cooling anticipator is not adjustable. It preheats the bimetal to prevent temperature drop too far below set point.

---

---

**▼ CAUTION**

Do not short (or jumper) terminals on the primary control in the heating system. The thermostat may be damaged.

---

## CHECKOUT

**System Switch:** Heat = heating only.

Cool = cooling only.

**Fan Switch:** On = continuous fan.

Auto = fan runs on demand.

Verify that the thermostat is level.

### Heating

1. Verify heat anticipator setting.
2. Set switches to Heat and Auto. Set point should be adjusted below the room temperature.
3. Adjust the set point slowly upward until the thermostat switch closes. The fan will start up. This should be within 2F degrees of room temperature.

### Cooling

1. Set switches to cool and auto. Set point should be adjusted above room temperature.
2. Adjust set point slowly downward until thermostat switch opens. The fan will start up. This should be within 2F degrees of room temperature.

## THEORY OF OPERATION

A mercury switch is attached to a bi-metallic strip that expands when it is heated and contracts when it is cooled. As the bimetal strip moves the mercury in the glass vial shifts from one end to the other making or breaking the heating or cooling switch.

## MAINTENANCE

The 31-10X series requires no maintenance. Replace defective modules.

Regular maintenance of the total system is recommended to assure sustained, optimum performance.

## FIELD REPAIR

None. Replace any damaged or failed components with functional replacements.

## DIMENSIONAL DATA

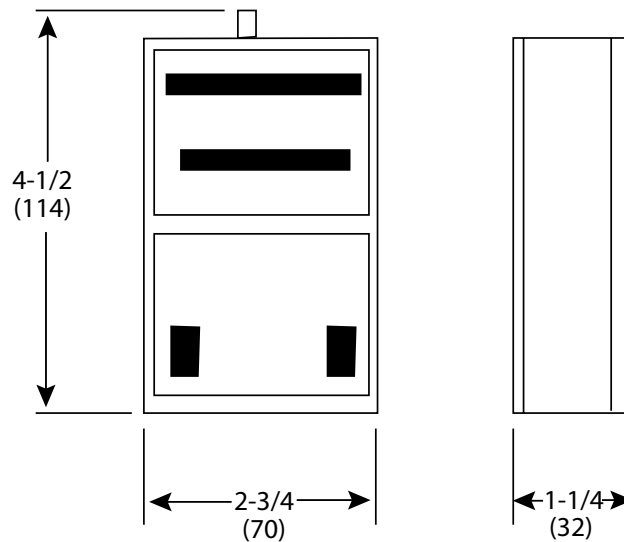

Figure-4 31-102 and 31-103 Dimensions.