

Product Data

A/ASCS Series Split-Core Adjustable Current “Status” Switches

Product Description

The A/ASCS and A/ASCSX series current switches are available in a split-core with either Normally-Open (N/O) or Normally-Closed (N/C) output configurations. All of these sensors will have a solid-state output with an adjustable trip point (setpoint). These current switches are ideal for providing status information on any type of AC current using equipment.

These current switches should be used in applications in which a current switch with adjustable trip point is required. A change in the operating current may indicate motor failure, belt loss/slippage, or mechanical failure. Any time one of these events occurs, the current can significantly increase or decrease, thus tripping the sensor, and notifying the Building Management System of an alarm condition.

The A/ASCS and A/ASCSX series current switches can be used to monitor devices with a maximum continuous operating current of 200 to 250 Amps depending on the model. These current switches will not need to be externally powered, since the power for the switch is induced from the conductor being monitored. Another great feature of the A/ASCS and A/ASCSX series current switches is that they include a Red and Green LED that will indicate the “Status” of the switch contacts.

Product Specifications

Sensor Power	Induced from monitored conductor
Amperage Rating	See Ordering Info on Back
Operating Frequency	40 to 1 kHz
Isolation Voltage	2,200 VAC
Max. Sensing Current Voltage	600 VAC
Output Switch Rating	A/ASCS (N/O): 0.3A @ 200 VAC/VDC A/ASCSX (N/C): 0.15A @ 300 VAC/VDC
Status LED Indication	Red LED - Above Trip Point Green LED - Below Trip Point
Aperture (Hole) Size	0.75", Accepts up to 350 MCM Cables
DIN Rail Size	35mm
Unit Weight	0.21 lbs
Operating Temperature Range	-15 to 40°C (5 to 104°F)
Operating Humidity Range	0 to 95% RH, non-condensing
Hysteresis (Dead Band)	10% Setpoint, Typical

Note: DO NOT use the LED’s to indicate whether the sensors have power applied to them.

Current

Attributes:

- Split-Core design is suited for retrofit applications
- Red and Green status LED’s
- Integral Din-rail mounting flange
- Models rated to 200 and 250 Amps
- Limited 5 year warranty
- UL94-5VB (enclosure rating)

Applications:

- Monitoring overload, underloads, and normal operating conditions
- Monitoring belt loss/ slippage
- Monitoring Filter Status
- Rated for industrial use

Dimensions

Split-Core

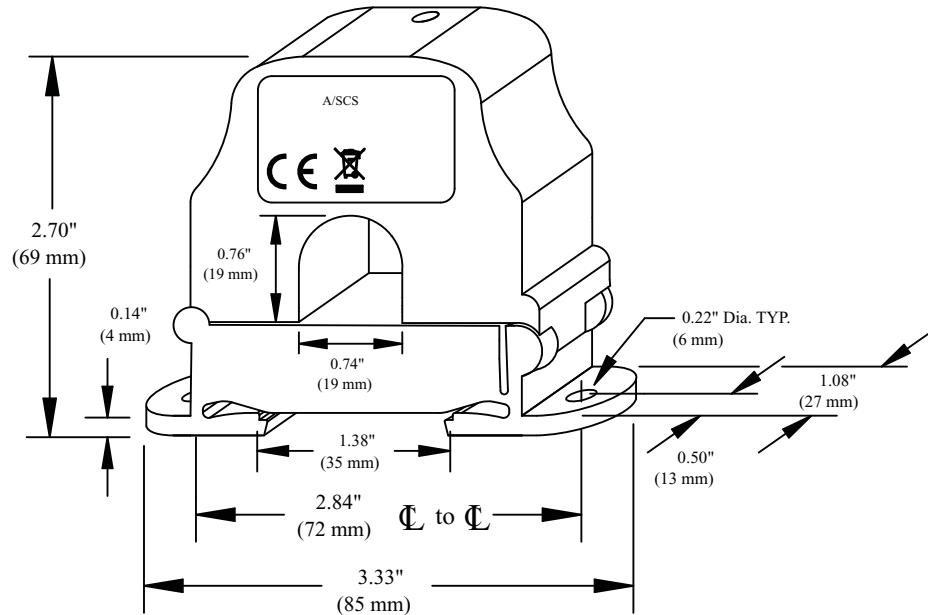

Ordering Information

Model #	Description	Adjustable Trip Point	Output Switch Rating
A/ASCS	Split-Core, Current Switch, N/O, 0-200A	3.00-200 Amps	0.30A @ 200 VAC/VDC
A/ASCS-L	Split-Core Current Switch, N/O, 0-200A	2.00-200 Amps	0.30A @ 200 VAC/VDC
A/ASCSX	Split-Core Current Switch, N/C, 0-250A	3.00-250 Amps	0.15A @ 300 VAC/VDC
A/ASCSX-L	Split-Core Current Switch, N/C, 0-250A	2.50-250 Amps	0.15A @ 300 VAC/VDC



Warning: Not intended to be used in Life & Safety Applications or for use in any hazardous locations.