

FEATURES

- ❖ 24V AC or DC operation
- ❖ Optically Isolated input
- ❖ Zero & Span potentiometers
- ❖ Small size 1.10" by 2.19"
- ❖ Two mounting options

APPLICATIONS

- ❖ Converts Phase cut to drive valve or damper actuators.
- ❖ Converts Phase cut to drive most VFD's
- ❖ Provides Phase cut isolation for multiple zone valves

DESCRIPTION

The ASM2 was designed as a phase cut to analog signal scaling module. The ASM2's phase cut input is optically isolated allowing the output to be connected to devices that use one side on the 24V AC power as common. The ASM2 utilizes the full phase cut signal to produce it's 0 to 10V DC output. It can be snap - track mounted for panel use or be potted with 12" pig-tail leads for field use. (See mounting options).

OPERATION

The ASM2 uses a half-wave rectifier for 24V AC/DC power input, with terminal 2 being common for the power supply and output common. The phase cut signal passes through an opto-isolator, then through a linearization filter, and on to two op-amp stages where it is scaled to the desired output signal.

WIRING CONFIGURATION

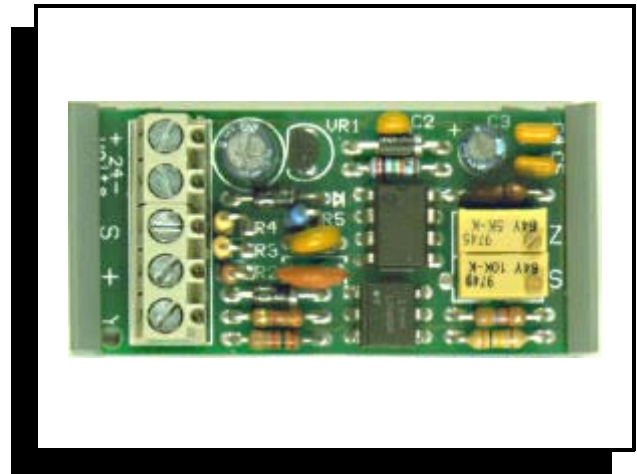
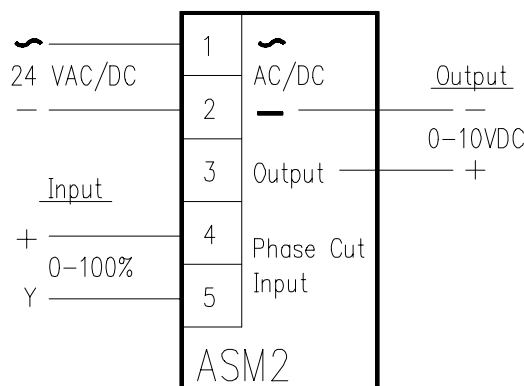

SPECIFICATIONS

SIZE:	1.10" L x 2.19" W x .75" H
MOUNTING:	2.187" RDI snap-track (supplied) or 2"L x 1"W Double sided foam tape
POWER:	24V AC, ± 10%, 50/60Hz, 0.6VA 24V DC @ 25mA (or filtered DC)
INPUT:	0 to 20V DC Phase cut
INPUT IMPEDANCE:	± 3.6KΩ
ACTION:	Dir. with 2 Hz filtering.
OUTPUT:	0 to 5 to 10V DC - Adjustable
ADJUSTMENTS:	ZERO & SPAN ± 20%
AMBIENT TEMP:	0 to 50° C.

ORDERING INFORMATION

ASM2/XXX/IX

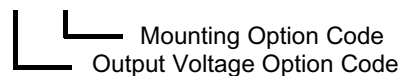

OUTPUT CODE OPTIONS

5V	-	0 to 5VDC
10V	-	0 to 10VDC
PC	-	0 to 20V phase cut

MOUNTING CODE OPTIONS

S	-	2.187" Snap Track
P	-	Potted enclosure double stick foam tape

PHYSICAL CONFIGURATION

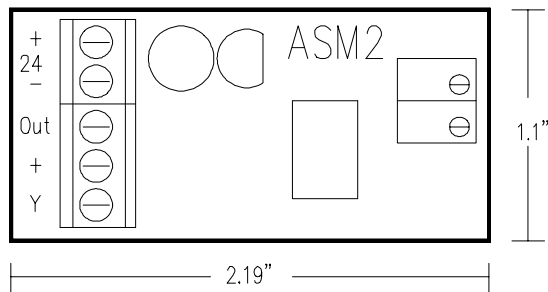

APPLICATION 1 - ACTUATOR INTERFACE - PHASE CUT TO 10V DC CONVERSION

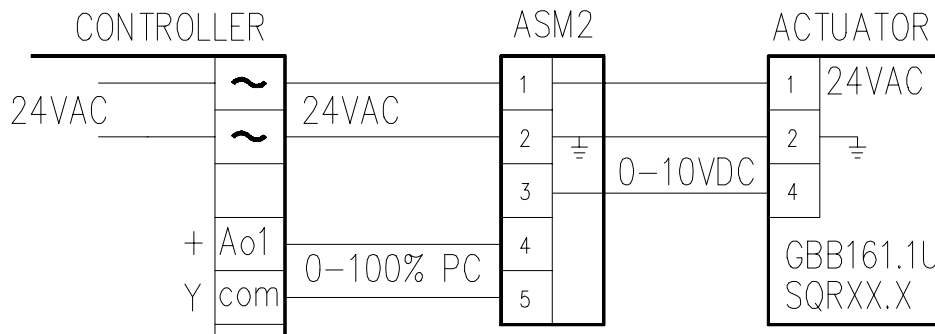

The ASM2/10V converts STAEFA's phase cut signal (0 to 100%) to a 0 to 10V DC output signal to drive Landis or Belimo damper actuators. The ASM2's phase cut input is optically isolated configured to accept the phase cut (+) & (Y) signal, the output signal is referenced to terminal 2 of the 24V AC/DC input.

APPLICATION 2 - VFD INTERFACE - PHASE CUT TO 10V DC CONVERSION

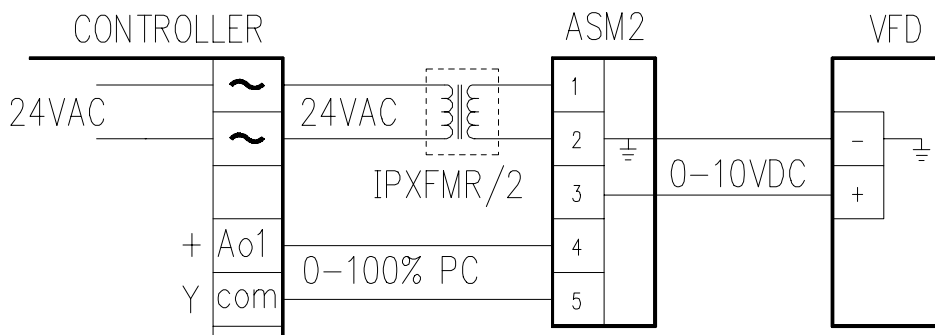

The ASM2/10V converts STAEFA's phase cut signal (0 to 100%) to a 0 to 10V DC output signal to drive a VFD. The ASM2's phase cut input is optically isolated configured to accept the phase cut (+) & (Y) signal, the output signal is referenced to terminal 2 of the 24V AC input which should be transformer isolated from the 24V AC powering the controller to avoid ground loop and/or noise problems generated by the VFD.

Call for other calibration ranges and versions.

APPLICATION 3 - ACTUATOR INTERFACE - PHASE CUT TO PHASE CUT ISOLATOR

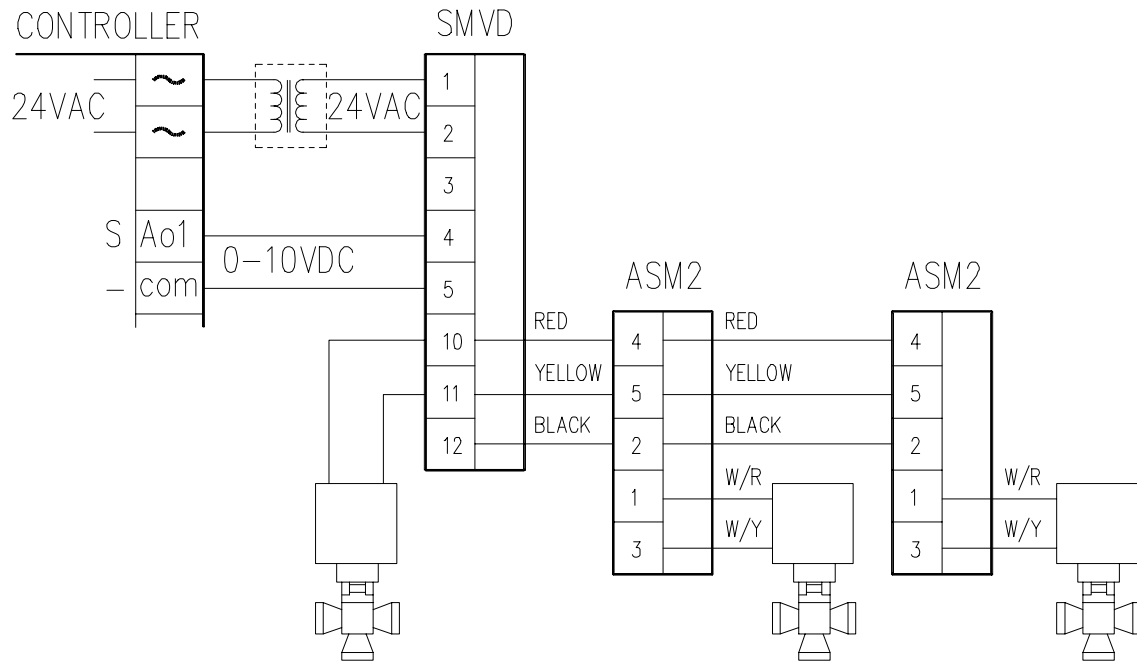

The SMVD converts the 0-10V DC or 4-20mA signal to a phase cut signal to drive the first Staefa zone valve and an ASM2/PC/PC/ISO and it's Staefa zone valve. The ASM2 is powered by the SMVD's bridge rectifier and provides an isolated phase cut signal a second zone valve. The only limitation to the number of ASM2's and zone valves is the wattage of the SMVD driver. A SMVD/UNI/40W can drive a total of four AMS1 valve actuators and three ASM2 isolators, an SMVD/UNI/80W can drive 10 valves. The AMS1 zone valve actuator is rated at 8 watts each. NOTE an isolation transformer is used when the controllers output common has the same potential as one side of the 24VAC power line .

Call for other calibration ranges and versions.