

Ammonia (NH₃) Analog Gas Transmitters



DESCRIPTION

Microprocessor-based gas transmitters with analog output signal for the detection of ammonia (NH₃) in the ambient air.

APPLICATION

To sense ammonia (NH₃) in a wide variety of commercial and industrial applications such as chiller equipment rooms, food storages, freezers, arenas, brewers and ventilation systems, etc. and transmit to any compatible electronic analog control, DDC/PLC control or automation system.

FEATURES

- For low temperature applications, -40°F (-40°C)
- Temperature compensated
- Continuous monitoring
- (0)4-20 mA, (0)2-10 VDC output, selectable
- Polarity protected
- Two-stage relay output control, optional
- Digital display, optional
- Electrochemical gas sensor, gas specific
- Easy plug-in sensor
- RFI/EMI protected
- Modular plug-in technology
- Easy maintenance

SPECIFICATIONS

Electrical

Power supply	24 VAC ± 15%, 50/60 Hz, or 17-28 VDC, polarity protected
Power consumption	22 mA (0.6 VA), max.
- w/relay package	35 mA (1.0 VA), max.
- w/heater	235 mA (6 VA), max.
RFI/EMI protection	5.0 W @ 1 ft. (0.31 m) radiated

Sensor Performance

Gas detected	Ammonia (NH ₃)
Sensor element	Electrochemical, diffusion
Range	0-300 ppm or 0-1000 ppm, fixed
Resolution	
- AT-1120	4 ppm
- AT-1125 "low temp"	< 15 ppm
Repeatability	
- AT-1120	< 3% of reading
- AT-1125 "low temp"	< 5% of reading
Long term sensitivity drift	
- AT-1120	< 5% / 6 months
- AT-1125 "low temp"	< 10% / 6 months
Response time	
- AT-1120	t ₉₀ < 35 sec.
- AT-1125 "low temp"	t ₅₀ < 20 sec., t ₉₀ < 120 sec.
Sensor life expectancy	
- AT-1120	24 months
- AT-1125 "low temp"	18 months, at normal operating environment
Sensor coverage	2,000 sq.ft., max. 3,000 sq.ft. (180 m ² , max. 280 m ²), under "ideal conditions"

Installation Location

Mounting height 1 foot (0.3 m) below ceiling

Type of Control

General Continuous proportional analog sensor signal output

PolyGard AT-1120/25 V3



NRTL Certification to STD
UL 61010-1
"Pending"



Analog output	(0)4-20 mA, load < 500 Ω; (0)2-10 VDC, load > 50K Ω; jumper selectable, polarity protected
Optional contact outputs	(2) relays, potential free
Environmental	
Permissible ambient	
- working temperature	
AT-1120	14°F to 104°F (-10°C to 40°C)
AT-1125	-40°F to 50°F (-40°C to 10°C)
- storage temperature	41°F to 85°F (5°C to 30°C)
- storage time	3 months, max.
- humidity	15 to 90% RH, non-condensing
- working pressure	Atmospheric ± 10%
Physical	
Enclosure, standard	
- material	Galvanized steel w/zinc coating, corrosion resistant
- color	Light gray
- protection	NEMA 1 (IP 42), general purpose
- installation	Wall (surface) mounted, or single gang electrical box
Dimensions (H x W x D)	5.59 x 5.59 x 2.48 in. (142 x 142 x 63 mm)

SPECIFICATIONS

Physical (cont...)

Cable entry	1 hole for 1/2 in. conduit for wall (surface) mounting, and 1 hole on back side of base plate for single gang electrical box mounting
Wire connection	Terminal blocks, screw type for lead wire
Wire size	Min. 24 AWG (0.25 mm ²), Max. 14 AWG (2.5 mm ²)
Wire distance	
- mA signal	Max. loop resistance 500 Ω (= wire resistance plus controller input resistance)
- V signal	1,500 ft (500 m), max. w/20 AWG (0.5 mm ²) wire
Weight	0.8 lbs. (0.36 kg)
Calibration	Adjustment via onboard zero and gain potentiometers

Approvals/Listings

- unit rating	NRTL Certification to STD ANSI/UL 61010-1 – “Pending” CE EMV-Compliance 2004/108/EWG, low voltage directives 73/23/EWG
---------------	---

Warranty

Two years material and workmanship, 12 months normal exposure for sensor element

ORDERING INFORMATION

AT-1120 - 0 - 000 - 1 (Product label “AT-1120/25-x-xxx-x V3”)

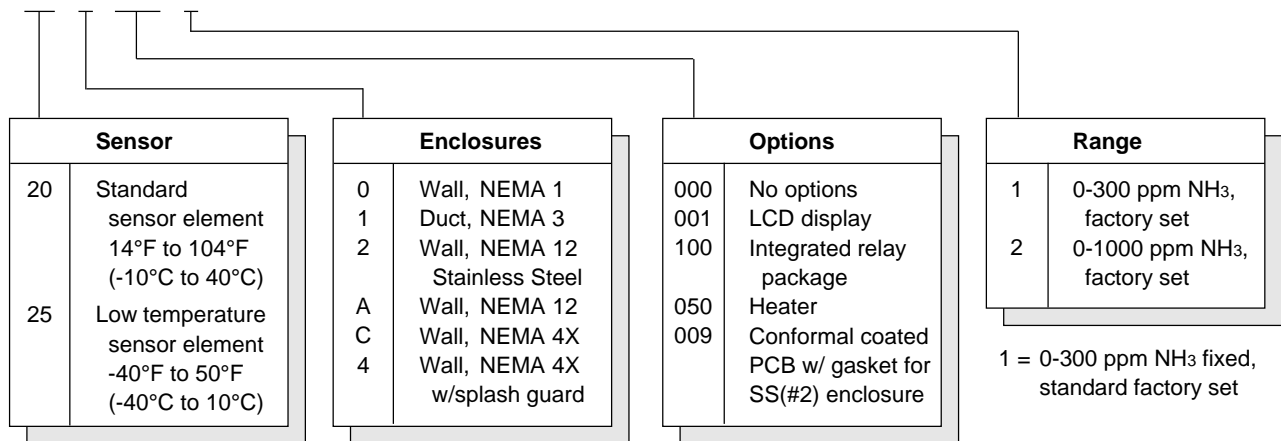

20 = Standard sensor

0 = Standard enclosure

000 = No options

Note: Relay package only for AT-1120 version

1 = 0-300 ppm NH₃ fixed, standard factory set

OPTIONS

<p>Digital Display</p> <p>Liquid crystal display "LCD", w/o backlight, two lines, 16 characters, 1/10 digit resolution</p> <p>Display NH₃ ppm values</p> <p>Permissible ambient - working temperature</p>	<p>Liquid crystal display "LCD", w/o backlight, two lines, 16 characters, 1/10 digit resolution</p> <p>NH₃ ppm values</p> <p>-4°F to 158° (-20°C to 70°C)</p>	<p>Wall mounted "4"</p> <p>- material - color - installation - dimensions</p> <p>- cable entry</p>	<p>NEMA 4X (IP 65), w/splash guard ABS UL94 V0 Light gray Wall (surface) mount 4.80 x 4.72 x 3.42 in. (122 x 120 x 87 mm) (1) PG 13.5 compression fitting, removeable, hole fits 1/2 in. conduit conductor</p>
Enclosures			
<p>Duct mounted "1"</p> <p>- w/probe</p> <p>- cable entry</p>	<p>NEMA 3 (IP45) 7/8 in. (22 mm) diameter and 7.16 in. (182 mm) length 1 hole for 1/2 in. conduit</p>	<p>Relay Package "Only for AT-1120 version"</p> <p>Type</p>	<p>(1) SPDT (R1), and (1) SPST-NC or SPST-NO (R2), jumper selectable 30 VAC/VDC, 0.5 A, max.</p>
<p>Stainless Steel "2" (Wall mounted)</p> <p>- material - color - dimensions (H x W x D)</p>	<p>NEMA 12 (IP55) Stainless steel V2A Natural, brushed 4.5 x 5.35 x 1.8 in. (113 x 135 x 45 mm)</p>	<p>Contact rating Setpoint (factory set)</p> <p>- 0-300 ppm version</p>	<p>Lo/SPDT = 80 ppm* Hi/SPST = 250 ppm* Lo/SPDT = 250 ppm* Hi/SPST = 800 ppm*</p>
<p>Wall mounted "A"</p> <p>- material</p> <p>- conformity - color - installation</p> <p>- dimensions (H x W x D)</p> <p>- cable entry</p>	<p>NEMA 12 (IP55) Polycarbonate, UL 94-HB, fire-retardant UL 50 Light gray Wall (surface) mounted, or single gang electrical box 5.12 x 3.70 x 2.25 in. (130 x 94 x 57 mm) 1 hole for 1/2 in. conduit for wall (surface) mounting, and 1 hole on back side of base plate for single gang electrical box mounting</p>	<p>- 0-1000 ppm version</p> <p>Switching differential (factory set)</p>	<p>15 ppm* * other values on special request at time of ordering</p>
<p>- enclosure approval</p>	<p>UL Listed, E208470 CSA Certified, E208470</p>	<p>Relay mode (factory set)</p>	<p>De-energized for each relay, energized (fail-safe) mode on special request</p>
<p>Wall mounted "C"</p> <p>- material</p> <p>- conformity - color - gas inlet - installation - dimensions (H x W x D)</p> <p>- cable entry</p> <p>- enclosure approval</p>	<p>NEMA 4X (IP65) Polycarbonate, UL 94-HB, fire-retardant UL 50 Light gray Special moisture filter protection Wall (surface) mount 5.12 x 5.12 x 2.95 in. (130 x 130 x 75 mm) (1) PG 13.5 compression fitting, removeable, hole fits 1/2 in. conduit conductor</p> <p>UL Listed, E208470 CSA Certified, E208470</p>	<p>Status indicator Relay approval</p> <p>Heater, built-in</p> <p>Ambient temperature Power consumption Thermostatic control</p>	<p>(2) LEDs, one for each relay UL Recognized, E41515 CSA, C22.2 No. 0, No. 14 (File No. LR31928) For low temperature environment, and using the standard sensor element -40°F (-40°C) 0.2 A (5 VA), max. 32°F (0°C) ± 5°F (3°C)</p>

WIRING CONFIGURATION

AT-1120/25

4-20 mA signal, 2-wire, loop-powered, 24 VDC

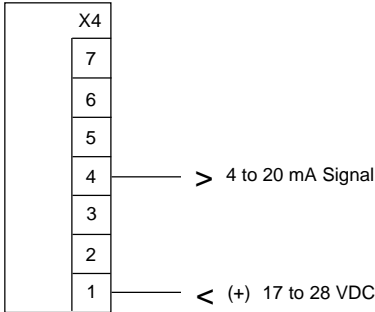

AT-1120/25

(0)2-10 VDC signal, 3-wire, 24 VAC or 24 VDC

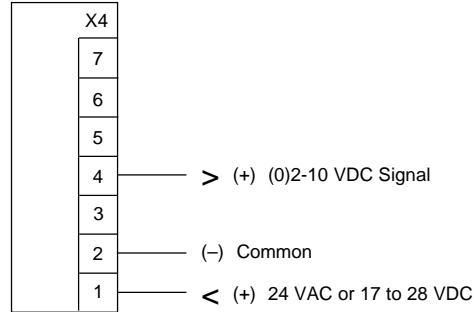

AT-1120/25

(0)4-20 mA signal, 3-wire, 24 VAC or 24 VDC**

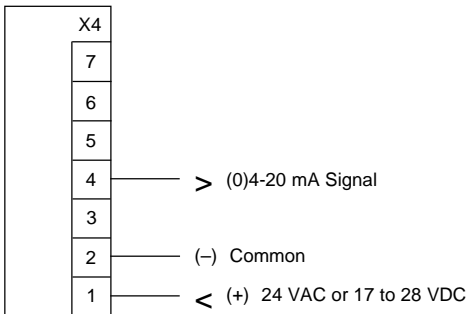

Jumper output signal range selectors:

- V-A Over both pins = VDC
Pins not covered = mA
- 0-20% Over both pins = 4-20 mA / 2-10 VDC
Pins not covered = 0-20 mA / 0-10 VDC

Notes:

2-wire loop-powered wire configuration allow only 4-20 mA signal.

Signal range jumper selection:

- V-A Pins not covered
- 0-20% Pins both covered

Optional relay package (available for AT-1120 versions only)

(0)4-20 mA signal, 3-wire, 24 VAC or 24 VDC**

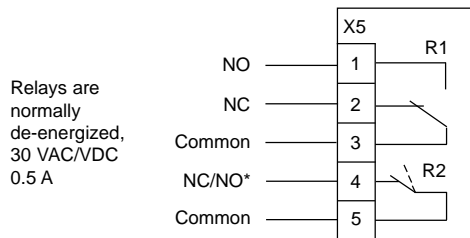

** For (0)4-20 mA signal with optional relay package, LCD and/or heater, the 3-wire configuration must be applied.

Twisted, shielded wire is recommended for 2- or 3-wire configurations.

Shield should be grounded only at the controller. DO NOT ground shield at both ends!

With optional heater:

The wiring must be sized appropriately for a power of 0.3 A, 24 VDC.

*Jumper SPST relay NC/NO selector:

- NC Covers top two pins = SPST-NC
- NO Covers bottom two pins = SPST-NO

Note: When using AT-1120 transmitter w/relay package as a stand-alone unit (no connection to a controller), pins on jumpers "V-A" and "0-20%" must be covered.

See Jumper output signal range selectors.