

FEATURES

- ❖ Input to output isolation
- ❖ 27, 40, or 80 watts output power
- ❖ Fused 24V AC power supply
- ❖ Input and power LED indication
- ❖ Input and power LED indication

APPLICATIONS

- ❖ MA/V DC to phase cut conversion
- ❖ DDC control of Staefa magnetic valves
- ❖ Phase cut signal scaling & sequencing
- ❖ High or low signal selection
- ❖ Minimum position override

DESCRIPTION

The DCIM-PCD (Digital Controller Interface Module - Phase Cut Driver) is used when interfacing between DDC controllers and Staefa magnetic valves or damper actuators. The DCIM can convert 4 to 20 mA or 0 to 10V DC to phase cut, and perform special phase cut to phase cut operations. The DCIM-PCD is available with a 27 watt, a 40 watt, or an 80 watt output power rating.

OPERATION

The DCIM main board consists of a 24V AC full-wave bridge rectifier, 20V DC regulated supply, two input sections and an amplifier section, and phase cut output section. The two inputs can be factory configured as both isolated, or as one isolated and one non-isolated. The isolated inputs can be either 0 to 20V phase cut, or 4 to 20mA. The non-isolated input will accept 0 to 10V DC. After the input signal is isolated, the amplifier section performs all signal conditioning (high or low signal selection, scaling, inverting, and sequencing). This conditioned signal then drives the phase-cut output section.

- The standard output ranges are as follows:
- 2 to 10V phase cut for damper actuators
 - 6 to 18V phase cut for Staefa magnetic valves
 - 1 to 17V phase cut for the Staefa AM1S valves
 - 0 to 20V phase cut full scale

It is **RECOMMENDED** that a 24V AC isolation transformer be used when the following condition exist:

- * 0 to 10V input signal comes from a device that uses a half-wave rectifier and is powered by the same 24V AC source as the DCIM-PCD.

Note: A half-wave power supply is being employed when the signal reference or common is the same as one side of the AC power source. This can be checked by measuring the resistance between the signal common terminal and the AC supply terminals. If either one measures approximately Zero ohms, then the power supply section in half-wave.



SPECIFICATIONS

SIZE:	4" L x 3" W x 1.5" H
MOUNTING:	3" RDI snap-track (supplied).
POWER:	24V AC \pm 10% 50/60Hz, 2VA* *NOTE: When sizing the power transformer the power rating of the valve must be added.
INPUT SIGNALS:	0 to 20V phase cut isolated 4-20mA isolated DC voltage 100K ohms isolation
OUTPUT SIGNALS:	0-20V phase cut 27, 40, & 80 watts (For 120W see SMVD)
ACTION:	Dir./Rev. with 2 Hz Filtering
ADJUSTMENT:	ZERO & SPAN \pm 20%
AMBIENT TEMP:	0 to 50°C.

WIRING CONFIGURATION

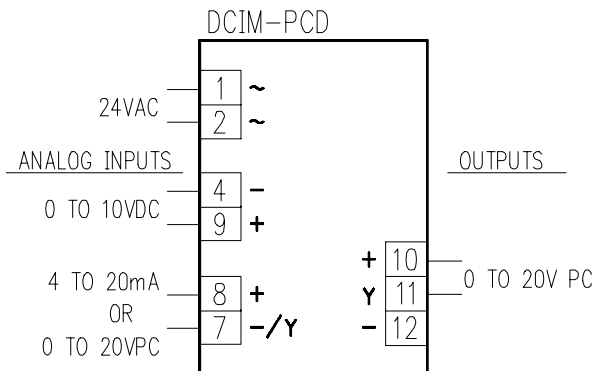

ORDERING INFORMATION

DCIM-PCD/XX/PCX-X/XXX

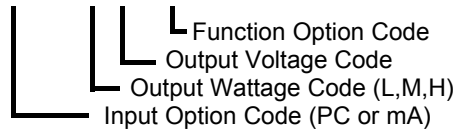

INPUT CODE OPTIONS

- PC - 10 - 90% phase cut isolated input
- mA - 4 - 20mA isolated input
- 135Ω - 135Ω, 2 wire potentiometer

*Note: Both the Minimum Position Pot and 0 to 10V DC input come standard as a second input on both phase cut and 4 to 20mA versions of the DCIM-PCD.

OUTPUT WATTAGE CODE OPTIONS

- L - 27 watts, phase cut low power
- M - 40 watts, phase cut medium power
- H - 80 watts, phase cut high power

OUTPUT VOLTAGE CODE OPTIONS

- 10 - 0-10V DC phase cut for damper motors
- 16 - 6-18V DC phase cut for magnetic valves
- 17 - 2-17V DC phase cut for AM1S actuators
- 20 - 0-20V DC phase cut full range

FUNCTION CODE OPERATION

- HS - High select of 2 input signals
- LS - Low select of 2 input signals
- AVE - Average of 2 input signals
- AMP - Isolated power amplifier

Note: for the following Function Codes it is RECOMMENDED to USE the SMVD interface module.

- INV - Inverted amplifier only
- SEQ - Sequencing on phase cut signals.
- SIV - Scaling / inverting on phase cut signals

ORDERING CODE EXAMPLES

- DCIM/MA/PCM-16 - 4 to 20mA & 0 to 10V DC input, 6 to 18V phase cut output, 40 watt valve driver. Field adjustable.
- DCIM/PC/PCL-16 - 10 to 90% phase cut & 0 to 10V DC input, 6 to 18V phase cut output, 27 watt. Field adjustable.
- DCIM/PC-PC/PCM-16-L - Lowest of two (2) 10 to 90% phase cut input signals, 6 to 18V phase cut output, 40 watt. Output voltage range is field adjustable.
- DCIM/MA-MA/PCL-20-L - Lowest of two (2) 4-20ma input signals, 0 to 20V phase cut output, 27 watt. Output voltage range is field adjustable.

Call for other calibration ranges and versions.

PHYSICAL CONFIGURATION

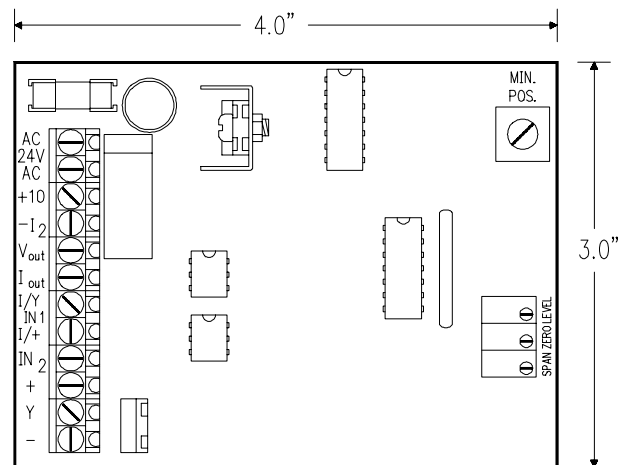

STAEFA'S RECOMMENDED WIRE LENGTH & SIZE CHART

NORMAL POWER	COPPER WIRE SIZE			
	18GA	16GA	14GA	12GA
27W	50'	75'	100'	120'
40W	40'	60'	75'	100'
80W	20'	30'	40'	60'

APPLICATION 1 - PHASE CUT AMPLIFIER / ISOLATOR

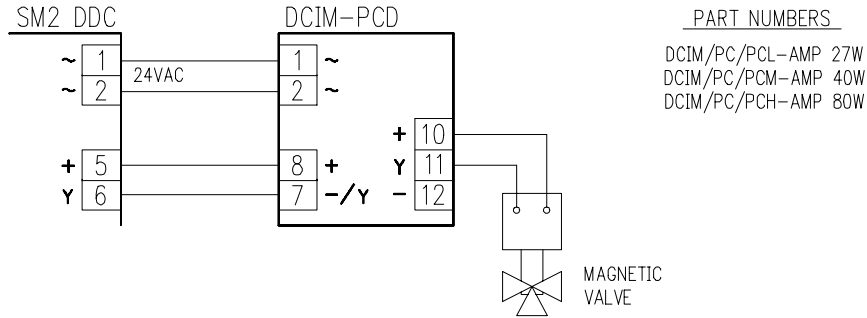

The DCIM/PC/PCL or PCM-AMP version is powered by the same transformer as the DDC controller and receives the phase cut signal through an opto-isolator. The isolator's output is used to drive the phase cut output transistor which can drive up to 3 1/8" magnetic valves (M3P80F 80 watt). The "amp" version has no on-board scaling.

APPLICATION 2 - PHASE CUT SCALING / INVERTING

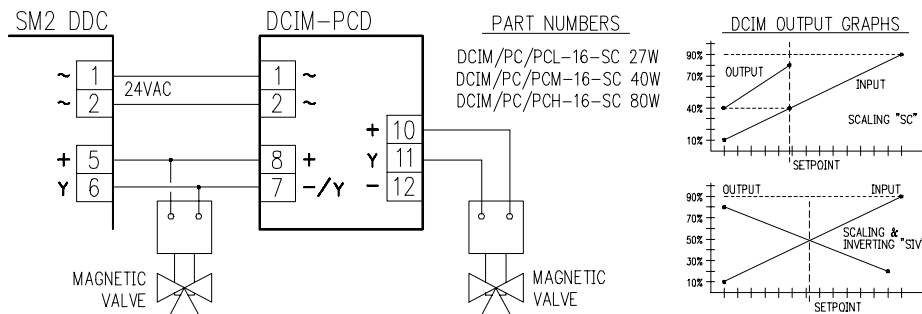

The DCIM phase cut scaling or inverting module converts the phase cut input signal to a DC voltage. This voltage is scaled or inverted to drive the phase cut output section so that sequencing or inverting action is possible. The scaling version would be used for two valves in sequence from the same input signal. One application would be 1/3, 2/3 steam valves. The inverting version would be for heating and cooling valves from the same output signal with the heating valve closed before the cooling valve starts to open.

APPLICATION 3 - PHASE CUT SIGNAL INVERTING

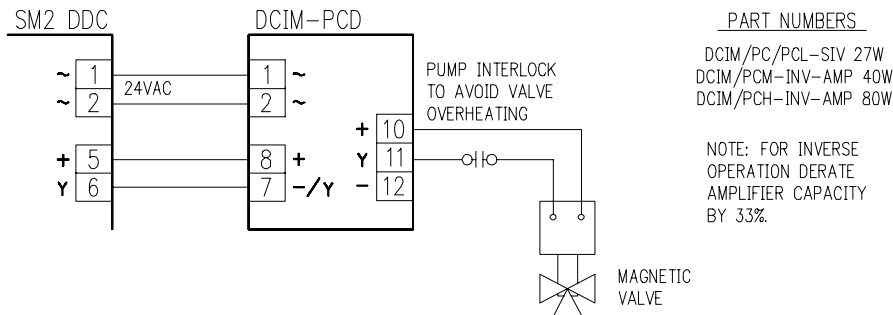

Phase cut signals can be inverted to operate control valves that are piped normally open. This normally open piping is not recommended because of bottom port leakage. However, if it is required, the DCIM should have extra current carrying capacity because the valve will normally operate in the 16 to 18 volt range. A pump interlock should be included to kill the power to the control valve so the valve does not overheat itself and the DCIM, when heating or cooling is not required.

Call for other calibration ranges and versions.

APPLICATION 4 - PHASE CUT WITH MINIMUM POSITION OVERRIDE INTERLOCK

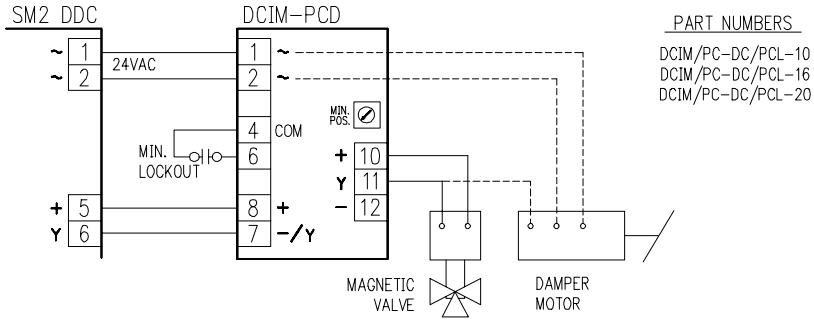

The DCIM module can receive both a 10 - 90% phase cut signal and a minimum position or override signal from either the on board minimum position potentiometer or an external 0 to 10V DC signal from a minimum position 5KΩ potentiometer. The onboard minimum position signal is fed out on terminal #6, where it can be interlocked through a status relay to terminal #4, when the relay energizes the minimum position signal goes to zero.

APPLICATION 5 - PHASE CUT WITH EXTERNAL MINIMUM POSITION POTENTIOMETER

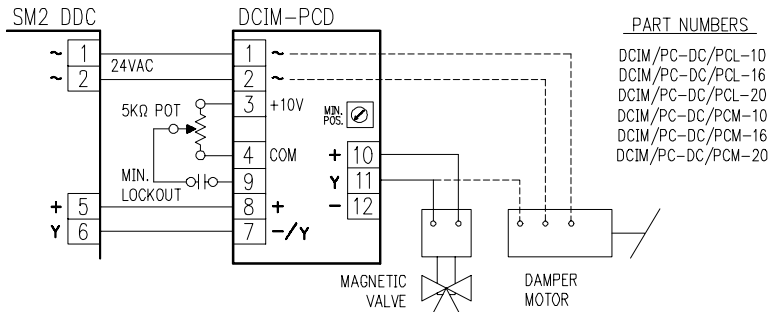

The DCIM module can receive both a 10 - 90% phase cut signal and a minimum position or override signal from an external 0 to 10V DC signal or an external minimum position potentiometer (5KΩ min.). The external minimum signal is through relay contacts and into terminal #9, when the relay de-energizes the minimum position signal goes to zero. The 5KΩ potentiometer connects to terminals #3 (+10V DC) and #4 (COM) with the wiper connecting to the interlock (status) relay, then to terminal #9.

APPLICATION 6 - 135Ω TO PHASE CUT CONVERSION

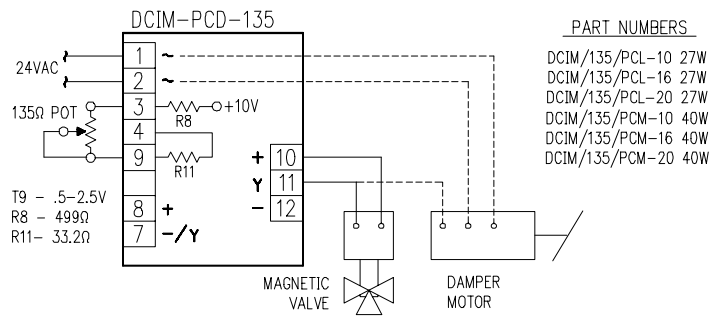

The DCIM/135Ω/PCX-X module is configured for a 135Ω, 2 wire potentiometer input, has two series resistors (R8 499Ω on board) between the 10V DC supply and terminal #3, and (R11 33.2Ω on board) between terminal #9 and common. The positive leg of the 135Ω pot connects to terminal #3 and the wiper connects to terminal #9. For a 3 wire pot connect both the common and wiper leg of the 135Ω pot to terminal #9.

Call for other calibration ranges and versions.

APPLICATION 7 - VOLTAGE / CURRENT TO PHASE CUT CONVERSION

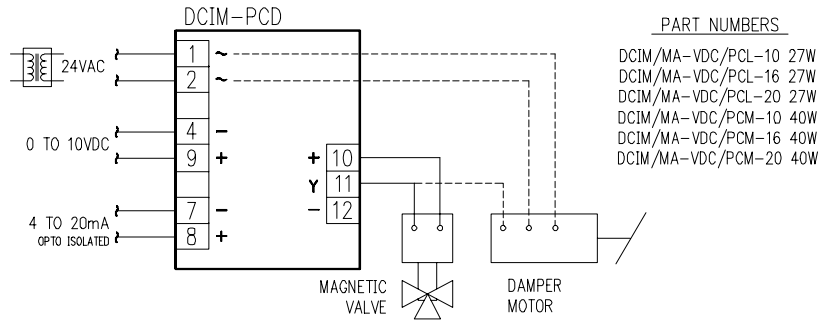

The DCIM board comes configured with both voltage and current inputs standard. The 4 to 20 mA (current) input is optically isolated and has a 500Ω input impedance, the 0 to 10V DC input has 10KΩ impedance. Phase cut utilizes a full-wave bridge rectifier, thus if the 0 to 10V DC input signal (-) is common to one leg of the AC power, then an isolation transformer is required, sized for both the DCIM and the valve.

APPLICATION 8 - TWO PHASE CUT SIGNALS LOW / HIGH SELECT TO PHASE CUT OUTPUT

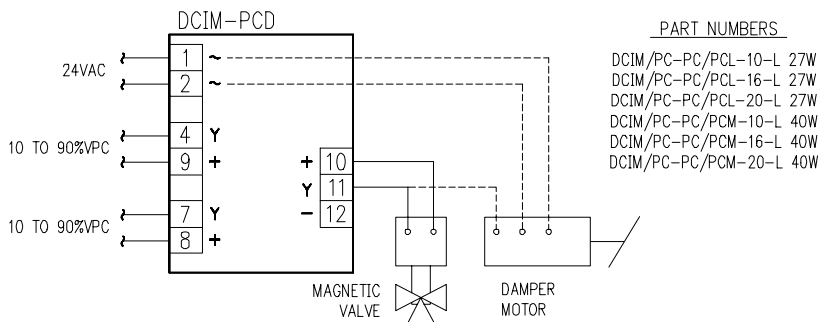

The DCIM/PC-PC/PCX-X has two isolated phase cut inputs and can be configured for either high or low signal select. Both inputs are converted to a DC signal fed into the high/low select circuitry. This signal drives the AMP and phase cut output section. Zero and span adjustments allow for field calibration.

APPLICATION 9 - TWO MA SIGNALS LOW / HIGH SELECT TO PHASE CUT OUTPUT

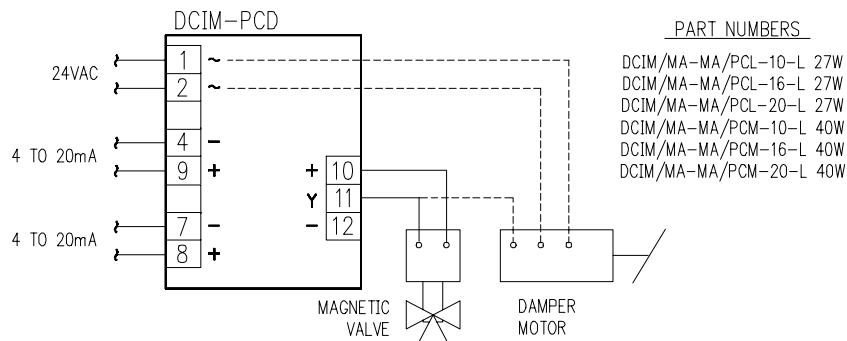

The DCIM/MA-MA/PCX-X is made the same as above however, it has two isolated mA inputs instead of phase cut. All other functions are identical.

Call for other calibration ranges and versions.

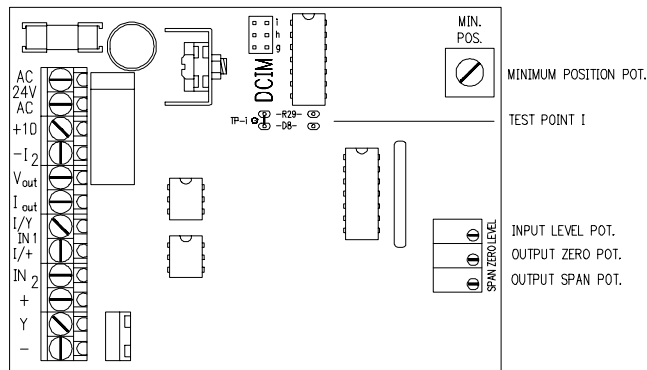
CALIBRATION TEST POINTS AND ADJUSTMENTS

There are four potentiometers on the DCIM module:

- 1 - Minimum position pot (single turn upper left hand corner)
- 2 - Level pot (Factory set for 2.5V DC at TPI with maximum input applied to terminals 7 & 8)
- 3 - Span pot used for Factory and field calibrations.
- 4 - Zero pot used for factory and field calibrations.

All field calibrations are made with the zero and span potentiometers **only**.

- Zero adjustment, clockwise, decreases output level, and is made with 100% input signal applied.
- Span adjustment, clockwise, increases signal differential, and is made with 0% input signal applied.

- Step 1 - Adjust minimum position pot all the way counter clockwise.
- Step 2 - Power board and apply maximum (100%) input signal. Adjust the Zero potentiometer to achieve the desired output level.
- Step 3 - Apply minimum (0%) input signal and adjust the Span potentiometer to achieve 75 to 80% of the desired output level.
- Step 4 - Apply maximum (100%) input signal. Adjust Zero potentiometer 75 to 80% of the desired output level.
- Step 5 - Repeat steps 3 & 4 until desired output is achieved.

* Only make adjustments of 75%-80% of the difference between the current output and the desired output, at a time. There is some inter-reaction between the ZERO and SPAN stages, and over-adjustment will occur if 100% adjustment is made to either potentiometer.

**Note: For phase cut inputs, a 10% phase cut input signal represents the minimum signal, and a 90% phase cut input signal represents the maximum signal. This is due to non-linearities in the phase cut signal that occur between 0 to 10% and again from 90 to 100%.