

FEATURES

- ❖ Easy to read numbers
- ❖ On-board power supply
- ❖ Field calibration adjustments
- ❖ Ordering choice of LCD or LED Display
- ❖ Compact size

APPLICATIONS

- ❖ Temperature indication
- ❖ Humidity indication
- ❖ Percentage of operation display
- ❖ Differential pressure indication

DESCRIPTION

The DIM3 is a 3½ digit panel meter that can be ordered in either a **LCD** or **LED** version. The DIM3 will display 000 to 1999 with the decimal available in any of the four possible positions. The DIM3 has larger digits that are easy to read at a distance. It has an on-board power supply for stand alone sensor operation.

OPERATION

The displays used on the DIM3 are the Datal's DMS-30 series digital panel meter. A sub-board is attached to the back of the meter that houses the power supply and input scaling circuitry. Stand alone sensors can be powered from the DIM3's supply by indicating the sensor type when ordering. The meter is factory calibrated, however ZERO and SPAN potentiometers are available for field adjustments. Please see field calibration and adjustments for instructions.

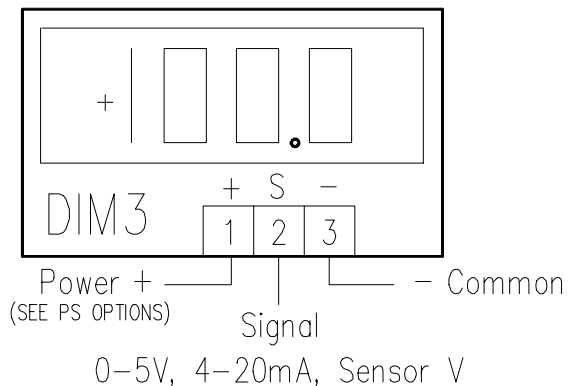
WIRING CONFIGURATION**SPECIFICATIONS**

SIZE:	2.17" W x 0.92" H x 1" D
MOUNTING:	Mount through 2.12"W x 0.88"H rectangular opening with a retaining clip or bezel option. (See Physical Configuration).
POWER:	+5V DC Standard +15V to 24V AC/DC optional
INPUT SIGNALS:	0-5V DC, 0-10V DC, 0-15V DC, 4-20mA, non-isolated AD590 sensor RTD sensors (100, 1k, 2k, & 10kΩ) Staefa sensors (all)
INPUT IMPEDANCE:	>1 meg ohms sensor inputs 200KΩ for voltage inputs 250Ω for 4-20mA input
LCD DISPLAY:	Datal part # DMS-30LCD 0.4" high 3½ digit LCD model.
LED DISPLAY:	Datal part # DMS-30PC 0.56" high 3½ digit LED model.
OUTPUT:	3½ digit display 0.000 - 1.999 optional 00.00 - 19.99 optional 000.0 - 199.9 standard 0000 - 1999 optional
ADJUSTMENTS:	ZERO & SPAN ± 20%
ACCURACY:	0.1% with linear input signal.
AMBIENT TEMP:	0-50°C

ORDERING INFORMATION

DIM3-XXX/XX/XXX/XXX/XXX-XXX

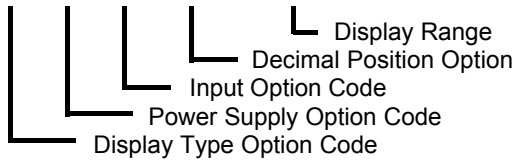

DISPLAY OPTION CODE

LCD	-	Liquid Crystal Display
LED	-	Light Emitting Diode (RED)

POWER SUPPLY OPTION CODES

05	-	5V DC
06	-	6V DC
24	-	9-24V AC or DC

INPUT OPTION CODES

1-5V	-	1-5V DC input signal
5V	-	0-5V DC input signal
10V	-	0-10V DC input signal
15V	-	0-15V DC input signal
mA-50	-	4-20mA input w/50Ω load
mA-249	-	4-20mA input w/249Ω load
AD590	-	Analog Devices AD590 sensor
RTD ○	-	RTD sensor ○
SCS □	-	Staefa sensors □
CUST	-	Custom sensor ★

- (specify RTD type, and temp. coefficient when ordering).
- (specify Staefa sensor type when ordering).
- ★(specify custom sensor signal and range when ordering).

DISPLAY OUTPUT RANGES

DP0	-	000 - 1999	no decimal point
DP1	-	00.0 - 199.9	displays 10th's
DP2	-	0.00 - 19.99	displays 100th's
DP3	-	.000 - 1.999	displays 1000th's

ORDERING CODE EXAMPLES

DIM3-LCD/ 05 / mA / DP1 / 000.0-100.0
 DIM3-LED/ 05 / 10VDC / DP2 / 00.00-19.99
 DIM3-LED/ 24 / RTD-1K / DP1 / 39 to 101°F
 DIM3-LED/ 24 / AD590 / DP1 / 39 to 101°F
 DIM3-LCD/ 05 / T-30X / DP1 / 39 to 101°F

Call for other calibration ranges and versions.

PHYSICAL CONFIGURATION

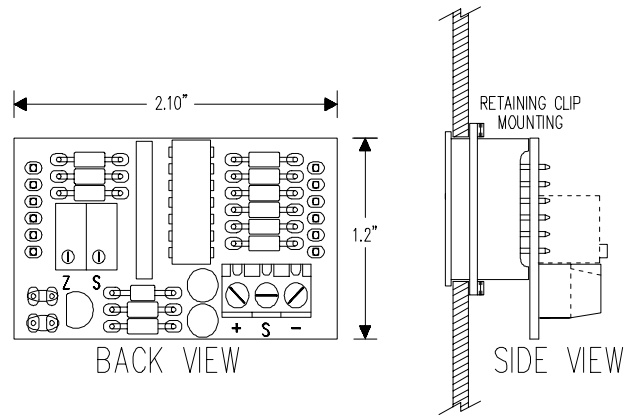

PANEL CUTOUT DETAIL

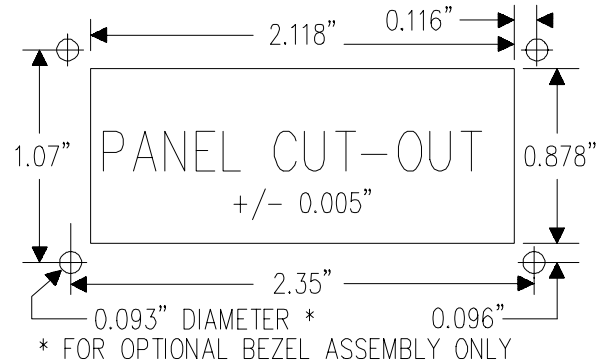

BEZEL MOUNTING DETAIL

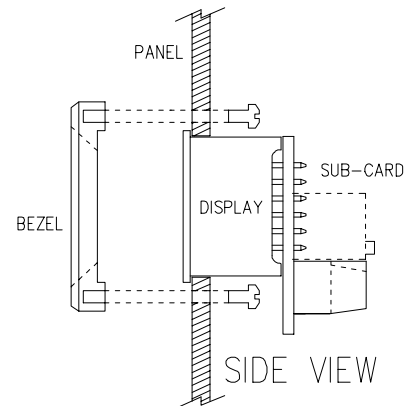

Optional Bezel mount Data # DMS-BZL1 & DMS-BZL2
 SEE panel cutout detail for mounting screws placement.

APPLICATION - 1 AD590 TEMPERATURE INDICATION

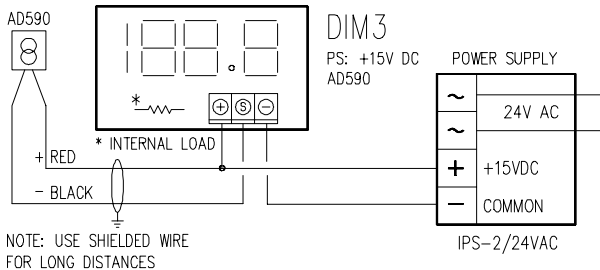

The DIM3 can be factory configured for an AD590 temperature sensor. Both the AD590 and DIM3 are powered by a 15 or 24V DC supply. The AD590's current signal is converted to a voltage by a 10kΩ .1% internal dropping resistor on the DIM3.

APPLICATION - 2 RTD-1K TEMPERATURE INDICATION

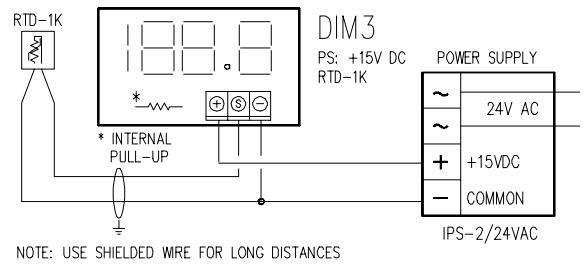

The DIM3 can be factory configured for an RTD-1K temperature sensor, with an internal pull-up resistor referenced to the 5 volt supply for stand alone operation. The DIM3 can also be factory configured for 5V, 15V or 24V DC power supply operation.

APPLICATION - 3 VOLTAGE SIGNAL INDICATION

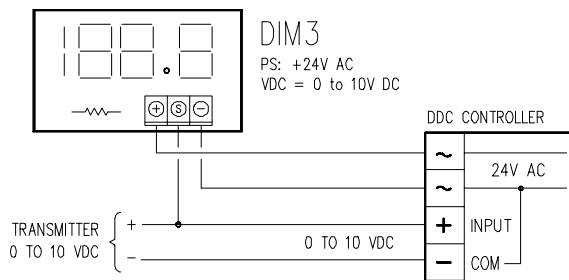

The DIM3 can be factory configured for a variety of voltage inputs. Standard input voltage signals are 1 to 5V DC, 0 to 5V DC and 0 to 10V DC.

APPLICATION - 4 4 to 20mA SIGNAL INDICATION

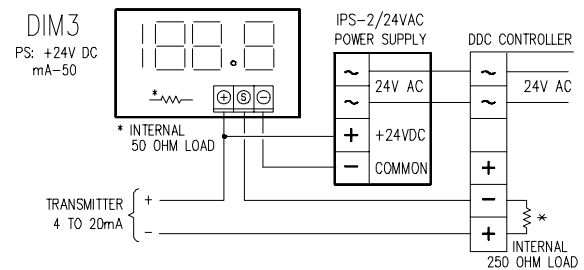

The DIM3 can be factory configured for 4 to 20mA input signals with 50Ω, 100Ω, or 250Ω load resistance. The DIM3 DDC controller are connected in series with transmitter.

APPLICATION - 5 MULTIPLE SIGNAL INDICATION WITH DIM 3 AND UNIVERSAL CHANNEL SELECTOR (UI8CH)

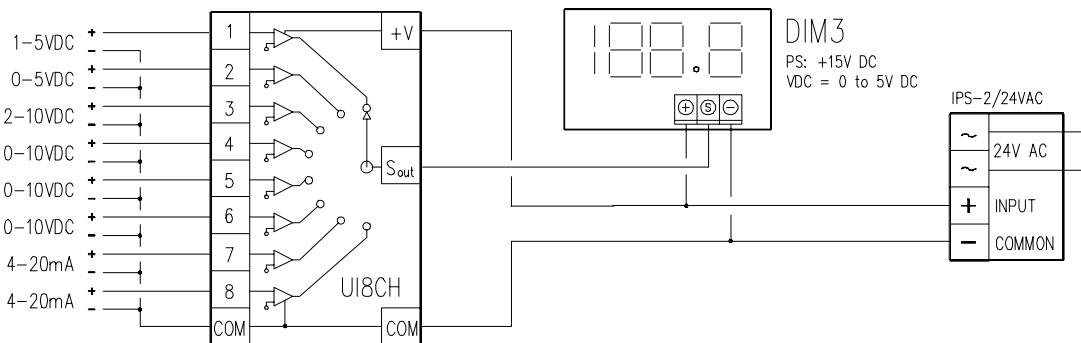

The DIM3 in conjunction with the UI8CH can display eight different temperature or voltage signals. The DIM3 is configured for the lowest and highest display value to be indicated. The UI8CH is customized for the various input signals to provide signal scaling, pull-up resistors for sensors, or load resistors for current signals. The UI8CH has ZERO and SPAN potentiometers for each channel for field calibration.

Call for other calibration ranges and versions.

APPLICATION - 6 4 to 20mA SIGNAL INDICATION

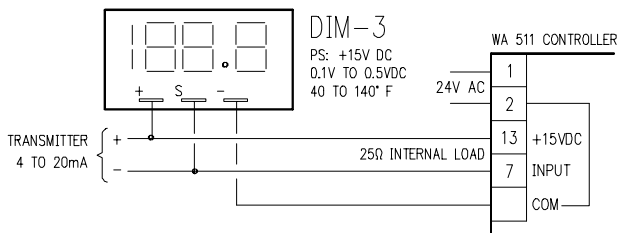

The DIM3's input can be factory configured to accept the voltage drop from the WA 511 controller's 4 to 20mA input internal load resistor (24.9Ω). The DIM3 power supply is configured to accept 15V DC from the controller.

APPLICATION - 7 4 to 20mA SIGNAL INDICATION

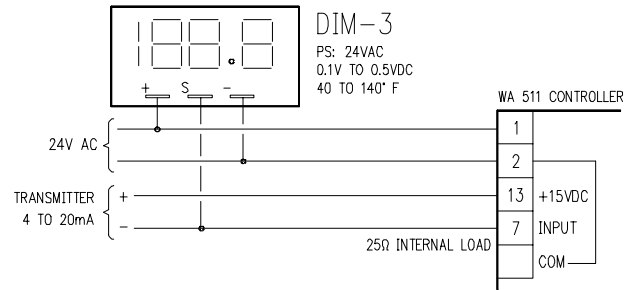

The DIM3's input can be factory configured to accept the voltage drop from the WA 511 controller's 4 to 20mA input internal load resistor (24.9Ω). The DIM3 power supply is configured to accept the same 24V AC as the controller.

APPLICATION - 8 KLIMO T-40 SIGNAL INDICATION

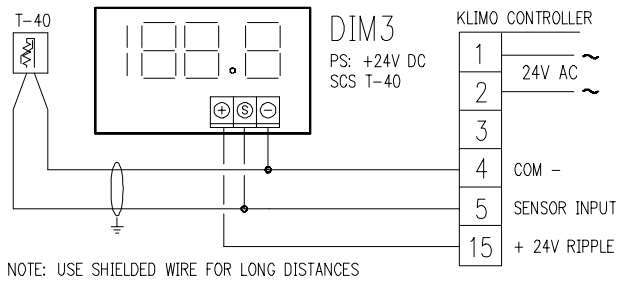

The DIM3's input is factory configured to accept the voltage from the Klimo controller's T-40 sensor input. The DIM3 power supply is configured to accept 9-24V AC/DC. The Dim3 uses a half-wave rectifier and **MUST** be connected to the Klimo's + phase cut terminal (24V ripple voltage) for power. If connected to 24V AC terminals it will cause damage to the Klimo controller.

Call for other calibration ranges and versions.