

FEATURES

- ❖ Jumper selectable analog input
- ❖ Jumper selectable output pulse timing
- ❖ Two 24V AC pwm Triac outputs

APPLICATIONS

- ❖ 0 - 20 mA to pulse width modulation
- ❖ 0 - 10V DC to pulse width modulation
- ❖ Phase cut to pulse width modulation
- ❖ Dual PWM valve or damper operation

DESCRIPTION

The DPCM is a 2 channel analog to pulse width modulation controller module built on the DFCM PC board. It's available in two versions; voltage and milli-Amp input to PWM 24V AC triac outputs, and phase cut input to PWM 24V AC triac outputs. The DPCM has two output time bases for each of the independent PWM outputs. The DPCM uses state of the art micro controller technology that provides superior system performance. The DPCM is useful when interfacing to PWM damper actuators, valves, or other PWM input devices.

OPERATION

The DFCM's 24V AC input uses a half-wave rectifier configuration, which is filtered and regulated to provide power for the on-board circuitry and to supply a 15V DC reference voltage on terminal 7. The DPCM uses an embedded micro controller to interpret the input signals and provide a corresponding PWM output signals. The analog inputs may be configured to accept 2-10V DC or 4 to 20mA signal by making a jumper selection on the voltage version. The phase cut version accepts a 10 to 90% phase cut signal. The PWM output signals can be configured for either of two time bases, 10 or 30 seconds, other time bases are available upon request.

The DPCM scales the analog input signal to 1 to 5V DC for the micro controller. It is then processed digitally and a PWM output signal is generated. The PWM output is updated every 10 or 30 seconds based on time base jumper selected, an 100% input will result in a pulse that is 85% of the selected time base.

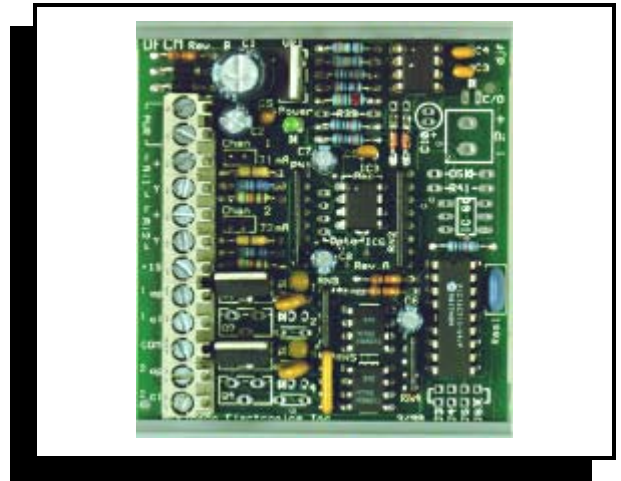

SPECIFICATIONS

SIZE:	2.75" L x 3" W x 1.1" H
MOUNTING:	3" RDI snap-track (supplied)
POWER:	24V AC, ±10%, 50/60Hz, 2VA
INPUTS:	10 - 90% Phase Cut 4 - 20 mA, 2 - 10V DC
OUTPUTS:	PWM @ 10 and 30 seconds Other time bases available upon Request.
OUTPUT RATINGS:	24V AC Triac @ 4Amps
AMBIENT TEMP:	0 to 50° C

WIRING CONFIGURATION

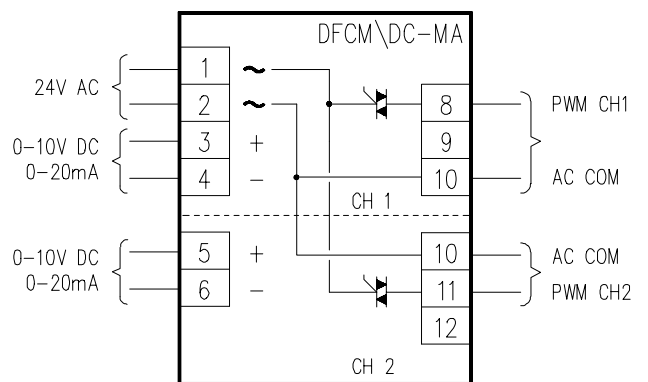

ORDERING INFORMATION

DPCM/XXX/PWM/XXX

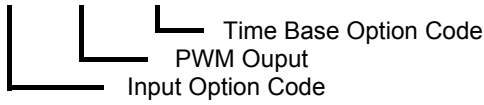

INPUT ORDERING CODE

- V-mA - 2 to 10V DC, 4 to 20mA inputs.
- PC - 10 to 90% phase cut, (isolated).

OPTION ORDERING CODE

- TB1 - 10 sec and 30 sec PWM time base
- TVC - "CONTROLLI" Thermic valve program
- TBC - Custom PWM time base ranges (2.5, 5, 10, 15, 30, 60, & 120 seconds).
- Op1 - Tracking or change over option.

PHYSICAL CONFIGURATION

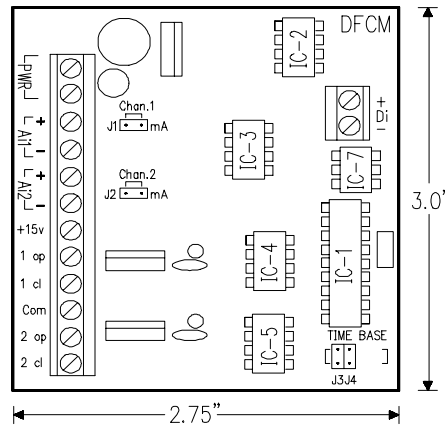

JUMPER DEFINITION

- J1 - Ch 1 voltage & mA input selection jumper. (Open - 2 to 10V, Closed - 4 to 20mA input).
- J2 - Ch 2 voltage & mA input selection jumper. (Open - 2 to 10V, Closed - 4 to 20mA input).
- J3 - Ch 1 output time base. (Open - 10 sec base, Closed - 30 sec base).
- J4 - Ch 2 output time base. (Open - 10 sec base, Closed - 30 sec base).
- J6 - Manual change over option, Ch 2's output controlled by Ch 1's input and will track Ch 1's output (same as Op1).

ORDERING CODE EXAMPLES

- DPCM/V-mA/TB1 - 2 to 10V DC or 4 to 20mA input to 24V AC PWM 10/30 second output pulse.
- DPCM/PC/TB1 - 10 to 90% phase cut input to 24V AC PWM 10/30 second output pulse.
- DPCM/PC/TBC-OP1 - 10 to 90% phase cut input & optional isolated change over input with custom PWM time base (specify two time base values, changes made in software in the micro controller).

APPLICATION 1 - DUAL ANALOG INPUT TO DUAL PWM OUTPUT

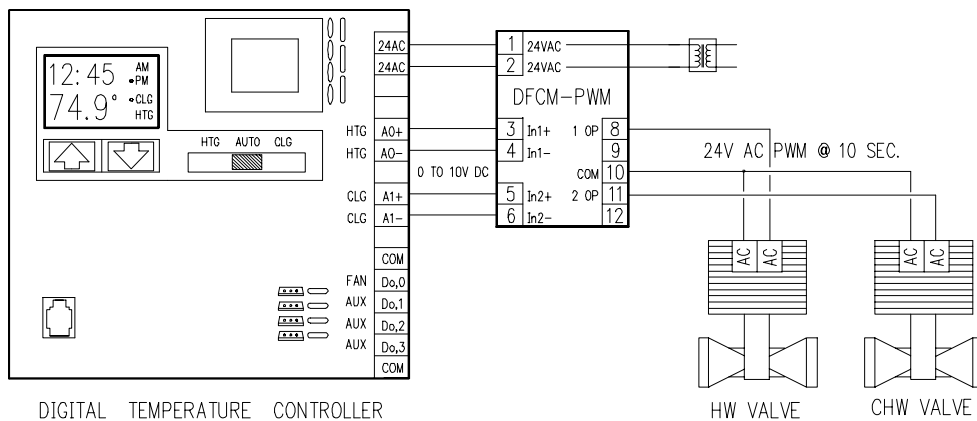

The DPCM/ V-mA is used to convert an analog input signal to a pulse width modulated (PWM) output. Select the jumper for the desired input for each channel, 2 to 10V DC (J1, J2 are open), or 4 to 20mA (J1, J2 are closed). The DPCM outputs uses a triac for each PWM output, rated @ 4 Amps, to switch the 24V AC. The output is updated every 10 or 30 seconds, based on the time base jumper selected (Ch1-J3, Ch2-J4). A 100% call for adjustment will give a 85% of the output time base selected.

APPLICATION 2 - DUAL ANALOG INPUT TO DUAL PWM OUTPUT TO DRIVE THERMIC VALVES

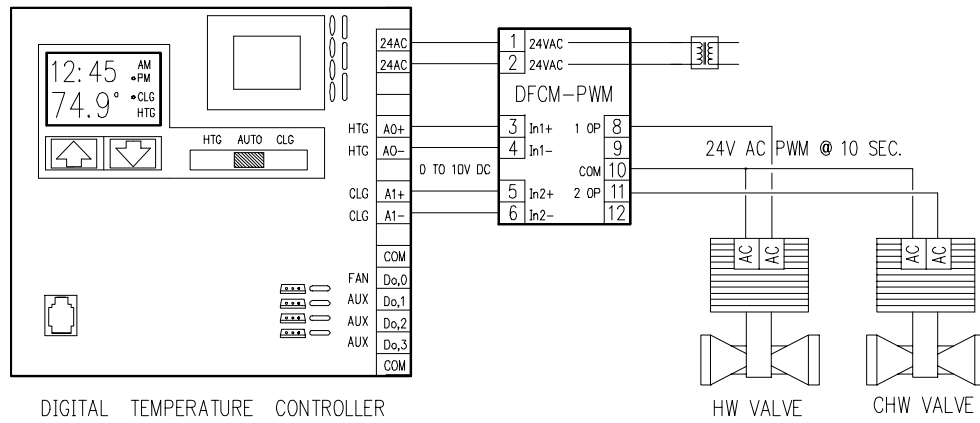

The DPCM/V-MA/TVC is used to convert an analog input signal to a pulse width modulated (PWM) output. Select the jumper for the desired input for each channel, 2 to 10V DC (J1, J2 are open), or 4 to 20mA (J1, J2 are closed). The DPCM outputs uses a triac for each PWM output, rated @ 4 Amps, to switch the 24V AC. The output is updated every 10 or 30 seconds, based on the time base jumper selected (Ch1-J3, Ch2-J4).

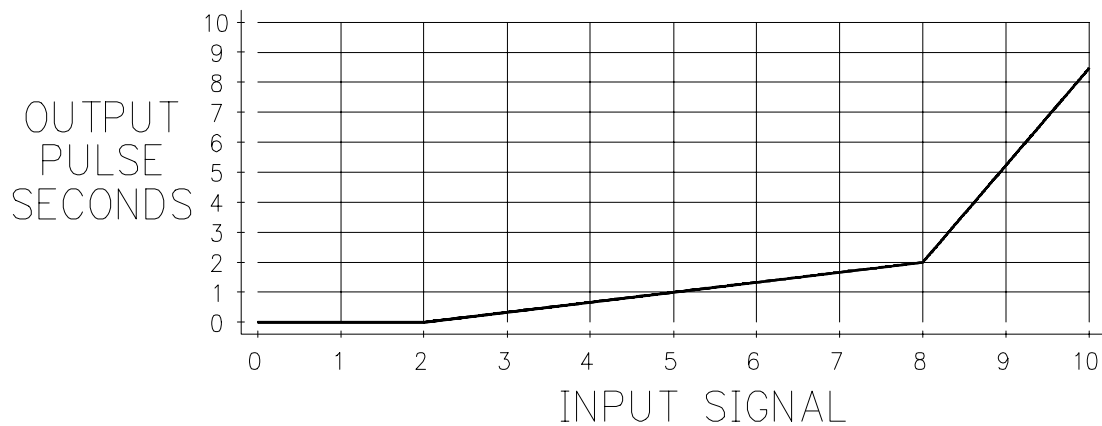

The DPCM/XX/TVC has a modified program that has been adjusted for the characteristics of a "CONTROLLI"® Thermic valve model #MVA 4.3. Once the thermic valve has warmed up, it only takes about a one second pulse in a 10 second window to maintain it's position. The thermic valve will fully open with a 2 second pulse every 10 seconds over a 13 minute period. At about 5½ minutes the valve begin to open, at 7 minutes it's about ¼ open, at 8½ minutes it's ½ open, at 10½ minutes it's ¾ open, and at 13 minutes it's full open. The output of the DPCM has been optimized to provide a wider range of control with the ability to provide a longer pulse signal when driving the valve from a fully closed or cold state.