

# Combustible RS-485 Digital Gas Transmitters



## DESCRIPTION

Digital RS-485 communicating, addressable gas transmitters, for the detection of combustible gases and vapors in the ambient air for direct daisy-chain/multi-drop link to the DGCx5 digital controller.

## APPLICATION

To sense a wide variety of combustible gases and vapors in commercial applications, such as boiler rooms (i.e. Methane), dry cell battery rooms (i.e. Hydrogen), gas/fuel spill locations (i.e. Gasoline, Hexane), laboratories and industries (i.e. Butane, Propane) and transmit to the DGCx5 central controller unit.

## FEATURES

- RS-485 serial communication
- Continuous monitoring
- Easy plug-in sensor
- Catalytic bead pellistor, long-life
- Temperature compensated
- Performance tested sensor to UL 2075
- 4-20 mA input from remote analog transmitter
- Polarity protected
- Overload & short circuit protected
- RFI/EMI protected
- Modular plug-in technology
- Easy maintenance

Combustible Gases/Vapors		% v/v*
Acetone	(CH <sub>3</sub> ) <sub>2</sub> CO	2.6
Ammonia	NH <sub>3</sub>	15.0
Benzene	C <sub>6</sub> H <sub>6</sub>	1.2
Ethylene	C <sub>2</sub> H <sub>4</sub>	2.3
Ethyl Acetate	CH <sub>3</sub> COOC <sub>2</sub> H <sub>5</sub>	2.2
Ethyl Alcohol	C <sub>2</sub> H <sub>5</sub> OH	3.3
Hydrogen	H <sub>2</sub>	4.0
Isopropyl Alcohol	(CH <sub>3</sub> ) <sub>2</sub> CHOH	2.2
Jet A	-	1.4
JP8	-	0.9
Methane	CH <sub>4</sub>	5.0
Methanol	CH <sub>3</sub> OH	6.7
Methyl Ethyl Ketone	C <sub>4</sub> H <sub>8</sub> O	1.9
n-Butane	C <sub>4</sub> H <sub>10</sub>	1.8
n-Heptane	C <sub>7</sub> H <sub>16</sub>	1.05
n-Hexane	C <sub>6</sub> H <sub>14</sub>	1.1
n-Octane	C <sub>8</sub> H <sub>18</sub>	0.95
n-Pentane	C <sub>5</sub> H <sub>12</sub>	1.4
Propane	C <sub>3</sub> H <sub>8</sub>	2.1
Toluene	C <sub>7</sub> H <sub>8</sub>	1.2

\* x% v/v = 100% LEL  
LEL = Lower Explosive Limit  
v/v = Volume by Volume

## SPECIFICATIONS

### Electrical

Power supply 16-28 VDC, polarity protected  
Power consumption, w/o options 35 mA (0.85 VA), max  
RFI/EMI protection 5.0 W @ 1 ft. (0.31 m) radiated

### Sensor Performance

Gas detected Combustible gases and vapors (refer to table)



NRTL Performance Tested & Certified  
Conforms to STD UL 2075

Sensor element Catalytic bead (pellistor), diffusion  
Range 0-100% LEL  
Detection Limit 0.5% LEL  
Accuracy ± 1% of reading  
Repeatability ± 2% of reading  
Long term zero point drift < 0.4% LEL<sub>methane</sub>/month  
Long term sensitivity drift < 2% LEL<sub>methane</sub>/month  
Response time t<sub>90</sub> < 10 sec.<sub>methane</sub>  
Sensor life expectancy 3 years, normal operating environ.  
Sensor coverage Dependent on the target gas

### Installation Location

Mounting height Dependent on the target gas

### Type of Control

General Continuous proportional sensor signal

Output signal for serial communication Digital, RS-485, proprietary protocol, 19200 baud

AT series remote gas transmitter input capability  
- analog input (1) 4-20 mA, overload and short circuit protected  
- power output 24 VDC, max. load 50 mA

## SPECIFICATIONS

### Environmental

Permissible ambient

- working temperature 14°F to 122°F (-10°C to 50°C)
- storage temperature 41°F to 104°F (5°C to 40°C)
- humidity 5 to 95% RH, non-condensing
- working pressure Atmospheric  $\pm$  20%

### Physical

Enclosure, standard

- material Galvanized steel w/zinc coating, corrosion resistant
- color Light gray
- protection NEMA 1 (IP 42), general purpose
- installation Wall (surface) mounted, or single gang electrical box

Dimensions (H x W x D) 5.59 x 5.59 x 2.48 in.  
(142 x 142 x 63 mm)

Cable entry 1 hole for 1/2 in. conduit for wall (surface) mounting, and 1 hole on back side of base plate for single gang electrical box mounting

Wire connection Terminal blocks, screw type for lead wire

Wire size Min. 24 AWG (0.25 mm<sup>2</sup>),  
Max. 14 AWG (2.5 mm<sup>2</sup>)  
*"Each terminal connection can handle two 18 AWG wires"*

Weight 0.7 lbs. (0.3 kg)

### Approvals/Listings

- unit rating<sup>▲</sup> NRTL Performance Tested & Certified  
Conforms to STD ANSI/UL 2075 CE  
EMV-Compliance 2004/108/EWG,  
low voltage directives 73/23/EWG

### Warranty

Two years material and workmanship

## OPTIONS

### Enclosures

#### Duct mounted "1"

- w/probe\* NEMA 3 (IP45)  
7/8 in. (22 mm) diameter and  
7.16 in. (182 mm) length  
1 hole for 1/2 in. conduit

#### Wall mounted "A"

- material NEMA 12 (IP55)  
Polycarbonate,  
UL 94-HB, fire-retardant  
UL 50
- conformity Light gray
- color Wall (surface) mounted, or  
single gang electrical box
- installation 5.12 x 3.70 x 2.25 in.  
(130 x 94 x 57 mm)
- dimensions (H x W x D) 1 hole for 1/2 in. conduit for wall  
(surface) mounting and 1 hole on  
back side of base plate for single  
gang electrical box mounting
- cable entry UL Listed, E208470  
CSA Certified, E208470
- enclosure approval NEMA 4X (IP65)

#### Wall mounted "C"

- material Polycarbonate,  
UL 94-HB, fire-retardant  
UL 50
- conformity Light gray
- color Special moisture filter protection
- gas inlet Wall (surface) mount
- installation 5.12 x 5.12 x 2.95 in.  
(130 x 130 x 75 mm)
- dimensions (H x W x D) (1) PG 13.5 compression fitting,  
removeable, hole fits 1/2 in.  
conduit conductor
- cable entry UL Listed, E208470  
CSA Certified, E208470
- enclosure approval NEMA 4X (IP65), w/splash guard

#### Wall mounted "4"\*

- material ABS UL94 V0
- color Light gray
- installation Wall (surface) mount
- dimensions (H x W x D) 4.80 x 4.72 x 3.42 in.  
(122 x 120 x 87 mm)
- cable entry (1) PG 13.5 compression fitting,  
removeable, hole fits 1/2 in.  
conduit conductor

### Heater, built-in

- Ambient temperature For low temperature environment  
-40°F (-40°C)
- Power consumption 0.2 A (5 VA), max.
- Thermostatic control 32°F (0°C)  $\pm$  5°F (3°C)

(▲) Performance tested with Methane and Propane gases

(\*) Duct's probe element and enclosure type "4" are not a part of the NRTL STD 2075 Certification

**ORDERING INFORMATION**

DT5 - 33xx - 0 - 1 0 4 1 (Product label "DT5-33xx-x-1xx1 V1")

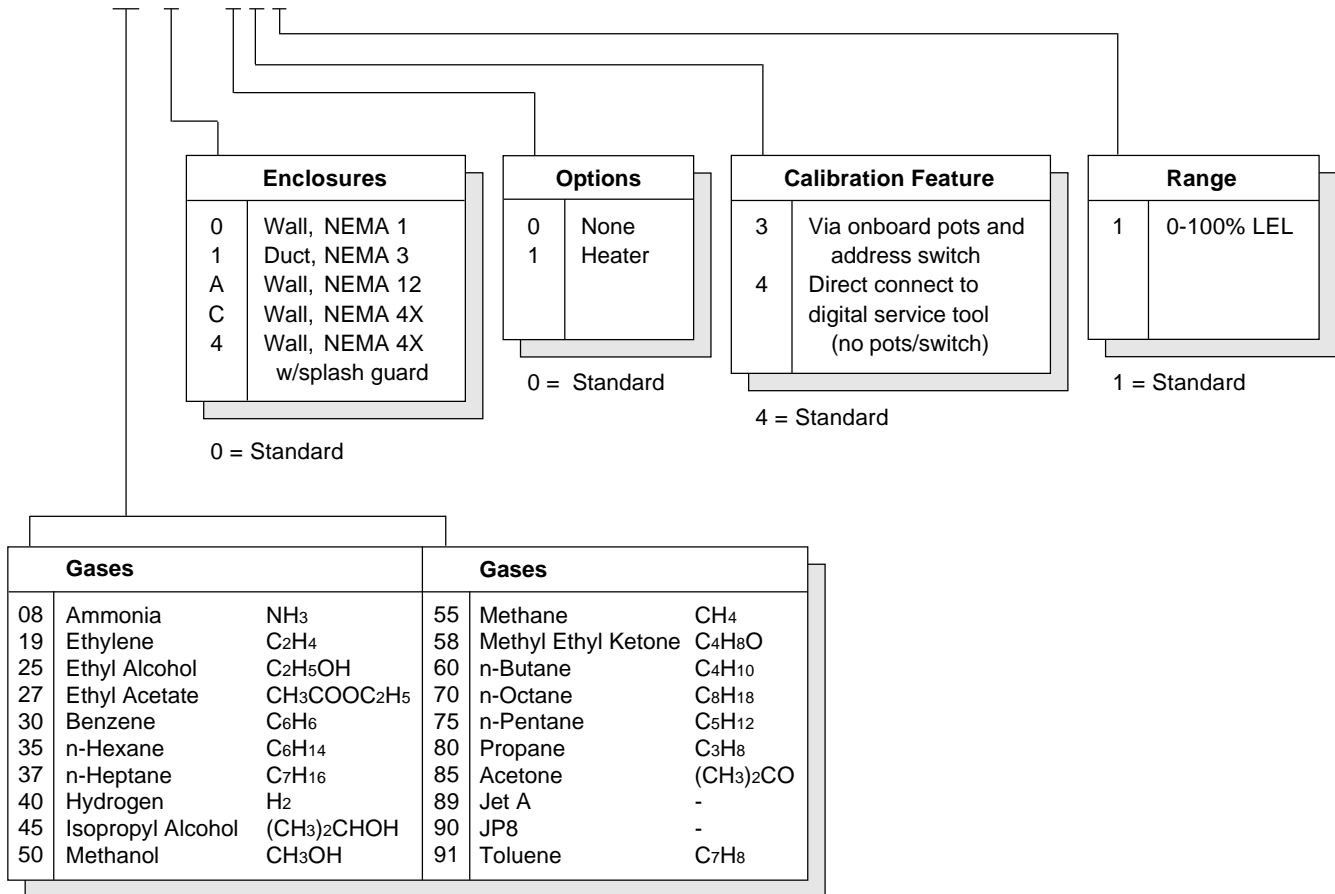

**WIRING CONFIGURATION**

DT5-3300

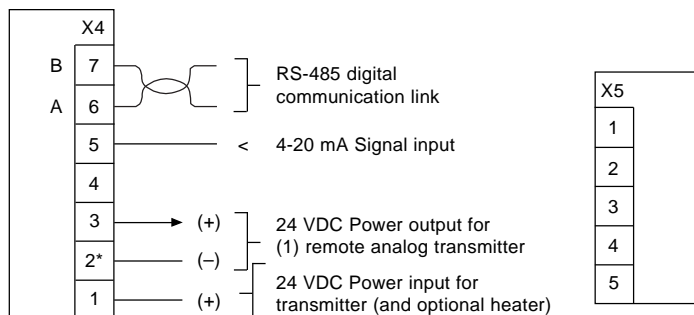

Notes:

- No wiring connection to terminal block X5

\* Terminal X4 No. 2, common (-), for both power input and output

**FIELD WIRING CONFIGURATION**

**4-20 mA analog transmitter piggybacked via RS-485 digital transmitter**

**DT5-3300**  
RS-485

**AT-11.. Version 3**  
4-20 mA loop powered

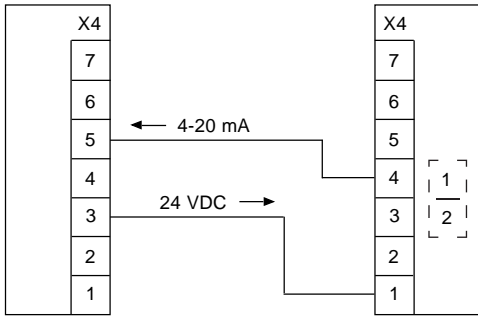

**DT5-3300**  
RS-485

**AT-33.. Version 3**  
4-20 mA, 3-wire

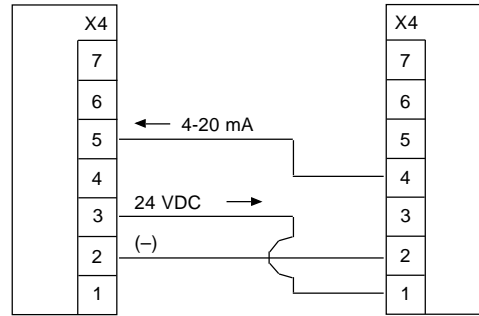

RS-485 digital communication and 24 VDC power supply, trunk/bus configuration

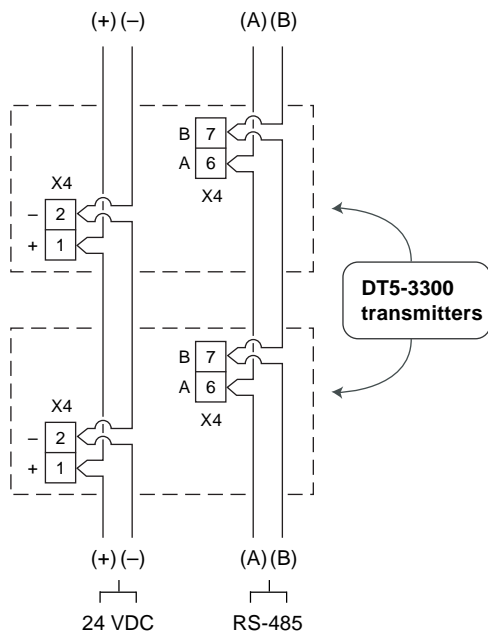

**Notes:**

- Use shielded twisted pair RS-485 cables with a minimum wire size of 18 AWG (0.75 mm<sup>2</sup>).
- Maximum daisy-chain trunk length is 2,900 ft. (900 m).
- Implement daisy-chain (multi-drop) communication and power supply between transmitter(s) and controller.
- Do not connect power to **A** and **B**; this may damage the transmitters and possibly the trunk protector "CON" linked on the same daisy-chain trunk.
- Daisy-chain between transmitters and controller **A** to **A**, **B** to **B**. Do not cross **A** to **B**, this creates malfunction of communication.
- No ground connections required for shielded cable, transmitters, and controller enclosure.
- Do not use high voltage lines in the same RS-485 communication cable conduit.

**With optional heater:**

The wiring and DC power supply must be sized appropriately for a power of 0.3 A, 24 VDC!