

DESCRIPTION

Electro-mechanical humidistats, to detect and control relative humidity in the air.

APPLICATION

To sense the relative humidity level in air, and for low- or line-voltage on/off single-stage control of humidifiers, dehumidifiers, compressors, solenoids, valves, relays, and other electrical equipment in commercial and industrial environments, i.e., offices, computer rooms, food storage warehouses, greenhouses, indoor swimming pools; dairy-, textile-, paper- and printing plants, and many more.

FEATURES

- Continuous monitoring
- Humid- or dehumidification on/off control
- Switched output, SPDT, 24...250 VAC, 15(8)A
- Scaled setpoint knob
- Easy to install
- Enclosures NEMA13 or NEMA4X
- Maintenance-free in clean air applications



“Probe sensing element can be saturated without damage”

SPECIFICATIONS

Sensor Performance

Relative humidity in air	0-100% rH (rF)
- operating range	30-100% rH (rF)
- condition	non-aggressive air
Sensor element	Polyga® bands of multi-synthetic fibers, water-resistant, washable, saturation without damage
Accuracy	
- above 50% rH (rF)	± 3-3.5% rH (rF)
- below 50% rH (rF)	± 4.0% rH (rF)
Permissible air velocity, maximum	1575 ft/min (8 m/sec); with gauze protection: 2970 ft/min (15 m/sec)
Response time	< 120 sec for 63% step change, at 394 ft/min (2 m/sec)

Type of Control

General	On/Off, single stage control, with (1) microswitch output
Stage level/setpoint	Field adjustable over the full operating range
- dial knob range	30-100% rH (rF)
- hysteresis/switching differential	4-5% rH (rF), fixed
Microswitch	SPDT, airtight
- contact rating	24...250 VAC, 15(8)A

Environmental

Permissible ambient	
- working temperature	32°F to 140°F (0°C to 60°C)
- storage temperature	-22°F to 140°F (-30°C to 60°C)
- humidity	0-95% rH (rF), non-condensing
- working pressure	Atmospheric ± 10%

Physical

Enclosure (base & cover)	
- material	ABS, fire-retardant
- color	White and light grey
- protection	Refer to the section: “Ordering Information”
Probe	
- material	High-grade steel, perforated, non-corroding
Installation	Probe into duct mount
Dimensions (HxWxD)	
- enclosure	4.73 x 3.15 x 2.84 in. (120 x 80 x 72 mm)
- probe	Ø 0.63 - Ø 0.79 x 8.67 in. (Ø 16 - Ø 20 x 220 mm)
Cable entry	(1) M20 compression fitting, removable, hole fits 1/2 in conduit connector
Wire connection	Terminal block, screw type for lead wire
Wire size	Max. 14 AWG (2.5 mm ²)
Weight	1.6 lbs. (0.7 kg)
Approvals / Listings	CE
Electromagnetic compatibility (EMC)	
- resistance interference, conformity	EN50082-2
- interference emission, conformity	EN50081-2
Warranty	18 months material and workmanship

ORDERING INFORMATION

	Humidistat, probe duct mount, single-stage
HG80	- w/external setpoint dial knob, NEMA13 (IP54)
HG80I	- w/internal setpoint dial, NEMA4X (IP64)
	<u>Accessory</u>
CH-VEL-GAUZE	High velocity duct probe protector, gauze to be used between: 1,575 ft/min (8 m/sec) and 2,970 ft/min (15 m/sec)

WIRING CONFIGURATION

HG80/80I

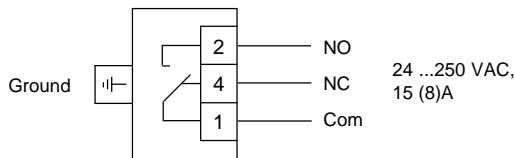

Sensing rH (rF)

- Below setpoint = 1 to 4 (humidification)
- Above setpoint = 1 to 2 (dehumidification)

Contacts Closed

INSTALLATION

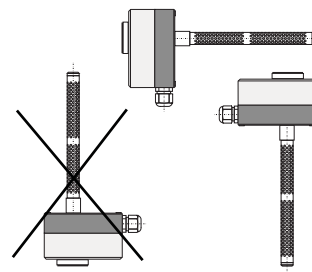
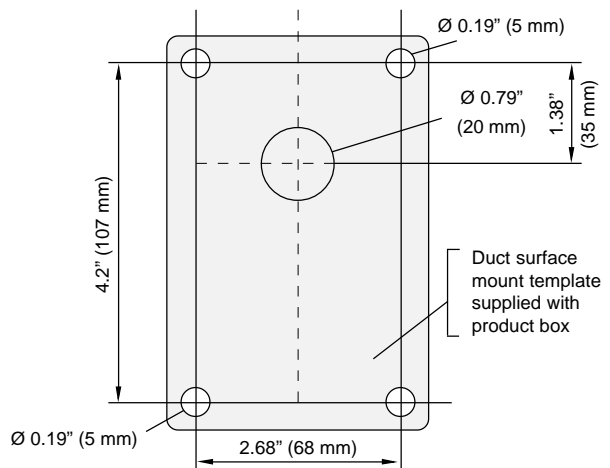

Attention

- Must avoid chemically aggressive atmosphere.
- Humidistat probe must be appropriately exposed to ventilation.

MOUNTING POSITION GUIDELINES

- Position: Designed for duct mounting in any position, except with the probe tip pointed up.
- Duct Diameter: Recommended minimum diameter (round ducts) or width (square ducts) is 10 in. (256 mm).
- Air Stratification (when the unit is mounted on the discharge side of the fan): Recommended location is at least 8 ft. (2.4 m) downstream from humidification equipment, where duct air and water vapor are sufficiently mixed. Avoid areas where the probe may be exposed to condensation.

DUCT PROBE ASSEMBLY & MOUNTING INSTRUCTIONS

1. Remove any excess insulation from the duct that prevents the probe from extending a minimum of 3 in. (76 mm) into the air stream.
2. Use the hole saw to make a 1/2 in. (12.7 mm) hole in the duct for inserting the probe.
3. Pull the plastic cover off the housing.
4. Insert the probe into the duct, and use the housing as a template to mark the location of the holes for the mounting for the mounting screws.
5. Remove the unit, and drill a 1/8 in. (3 mm) hole for each mounting screw.



IMPORTANT:

Remove the unit before drilling to prevent any metal remnants from falling onto the circuit board.

Seal any holes created during installation to help reduce drafts and for more accurate humidity readings.

6. Use a gasket, sealer, or other means to seal the area around the 1/2 in. (12.7 mm) hole between the unit and the duct.
7. Reinsert the probe, and secure the housing to the duct using the two No. 8 screws provided.

WIRING GUIDELINES



WARNING: Electrical Shock Hazard

Disconnect the power supply before wiring connections are made to prevent possible electrical shock or damage to the equipment.

Observe the following when wiring either type of element:

- Do not run low voltage wiring in the same conduit as line voltage wiring or other conductors that supply highly inductive loads.
- Use 10 or 14 AWG wire.
- Make all wiring connections in accordance with the National Electrical Code and all local regulations.

DUCT PROBE WIRING INSTRUCTIONS

To wire a duct probe model:

1. Reroute the wires from the controller to the unit through the conduit hole in the housing.
2. Break out the appropriate knockout from the cover with pliers to accommodate the wiring or conduit if used.
3. Connect the wires to the appropriate terminals of the wiring block.
4. Press the cover onto the base.