

Used in conjunction with any of our flow monitor or transmitter, non-magnetic flow sensors provide an accurate reading of the rate of liquid flow as well as total accumulated flow. A number of sensor models are offered, which cover applications for a wide range of pipe sizes and pressure/temperature specifications.

The flow sensors generate a frequency which is proportional to flow rate. An internal preamplifier allows the pulse signal to travel up to 2000 feet without further amplification. Power to operate the sensor is provided by the flow monitor. The impeller bearing assembly, shaft and O-rings are replaceable in the field.

The flow sensors feature a closed, six-bladed impeller design, using a proprietary, non-magnetic sensing technology. The forward-swept impeller shape provides higher, more constant torque than four-bladed impeller designs, and is less prone to fouling by water-borne debris. The forward-curved shape, coupled with the absence of magnetic drag, provides improved operation and repeatability, even at lower flow rates. As the liquid flow turns the impeller, a low impedance signal is transmitted with a frequency proportional to the flow rate.

Sensors of similar type are interchangeable, so there is no need for recalibration after servicing or replacement.

### Model I-228PV

These models feature a modified PVC tee with solvent weld socket end connections, and a removable, PPS or PVDF sensor insert. Sizes of 1 1/2", 2", 3" and 4" are available.

### Electronic Types

INTEC Controls provides several basic sensor configurations using the same impeller element. This allows for a wide range of applications and pipe sizes. Sensors are normally supplied with 20 feet of 2-conductor 20 AWG shielded U.L. type PTLC 105°C cable. All I-200 series sensor electrical components are self-contained. Pressure/temperature ratings for the various models are contained in the *Specifications* section of this manual. These models can be further described as follows:

#### "Standard" Sensor

Designed for indoor or protected area applications such as HVAC, pump control, and industrial process monitoring where the flow rates are between 0.5-30 feet/second and temperatures are below 140°F. Standard sensors are supplied with 20 feet of 2-conductor 20 AWG shielded U.L. type PTLC 105°C cable.



#### "IR" Sensor

Designed for below grade applications such as irrigation, municipal, and groundwater monitoring where the flow rates are between 0.5-30 feet/second and temperatures are below 140°F. IR sensors are supplied with two single conductor, 18 AWG solid copper wire leads 48 inches in length with U.L. Style 116666 direct burial insulation.

#### "FM/CSA" Sensor

Designed for indoor or protected area applications where intrinsic safety is required and the flow rates are between 0.5-30 feet/second and temperatures are below 140°F. FM/CSA sensors are supplied with 20 feet of 2-conductor 20 AWG shielded U.L. type PTLC 105°C cable. These sensors must be used with an approved safety barrier.

#### "Magnetic" Sensor

Designed for use with the Series I-1400 battery powered flow monitor in above or below or grade applications such as irrigation, municipal, and groundwater monitoring where the flow rates are between 1-30 feet/second and temperatures are below 140°F.



APPROVED

Not a controlled document.

# Specifications

## Wetted Materials (except tees)

- See Ordering Matrix

## Tee for I-228PV

- Schedule 80 PVC per ASTM D-2462 and D-2467. Virgin, unplasticized PVC resin, Type 1 cell classification 12454-B. Fittings and solvent carry approval for potable water by NSF and IAMPO.

## Pressure, Temperature Ratings

- Depends on hardware configurations. See Diagrams at end of this section.

## Recommended Design Flow Range

- ½ to 30 ft/sec

## Accuracy

- ± 1.0% of full scale over recommended design flow range

## Repeatability

- ± 0.3% of full scale over recommended design flow range

## Linearity

- ± 0.2% of full scale over recommended design flow range

## Transducer Excitation

- Quiescent current 600uA@8VDC to 35VDC max.
- Quiescent voltage ( $V_{high}$ )  
Supply Voltage - (600uA \* Supply impedance)
- ON State ( $V_{Low}$ ) Max. 1.2VDC@40mA current limit (15Ω+0.7VDC)

## Output Frequency

- 3.2 Hz to 200 Hz

## Output Pulse Width

- 5 msec ±25%

## Electrical Cable for Standard Sensor Electronics

- 20 feet of 2-conductor 20 AWG shielded U.L. type PTLC wire provided for connection to display or analog transmitter unit. Rated to 105°C. May be extended to a maximum of 2000 feet with similar cable and insulation appropriate for application.

## Electrical Cable for IR Sensor Electronics

- 48 inches of U.L. Style 116666 copper solid AWG 18 wire w/direct burial insulation. Rated to 105°C.

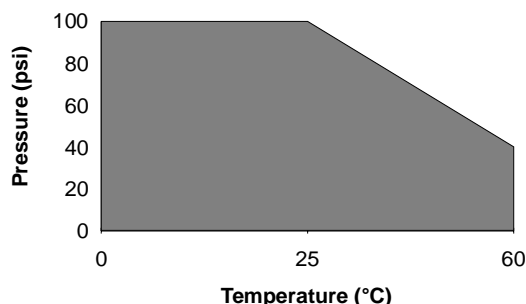

## I-200 Series Plastic Tee Sensors Matrix (1½" to 4")

Example: I-2		x	x	x	x	x	-	x	x	x	x
<b>Style</b>	Tee Mounted	28									
<b>Material</b>	PVC		PV								
	CPVC		CPV								
<b>Size</b>	1.5"		15								
	2"		20								
	3"		30								
	4"		40								
<b>Electronics Housing</b>	PPS		0								
	PVDF		1								
<b>ELECTRONICS</b>	Standard		5								
	IR-Irrigation (not available with PVDF sensors)		6								
	Magnetic		2								
	FM/CSA Approved		4								
<b>O-RING</b>	Viton		0								
	EPDM		1								
	Kalrez		2								
	Food Grade Silicone		3								
	Neoprene		4								
	Chemraz		5								
	Teflon Encapsulated Viton		6								
	Teflon Encapsulated Silicone		7								
	Buna N		8								
<b>SHAFT</b>	Zirconia Ceramic		0								
	Hastalloy C		1								
	Tungsten Carbide		2								
	Titanium		3								
	Monel		5								
	316 Stainless Steel		6								
	Tantalum		7								
<b>IMPELLER</b>	Nylon		1								
	Tefzel		2								
<b>BEARING</b>	Pennlon		1								
	Tefzel		2								
	Teflon		3								

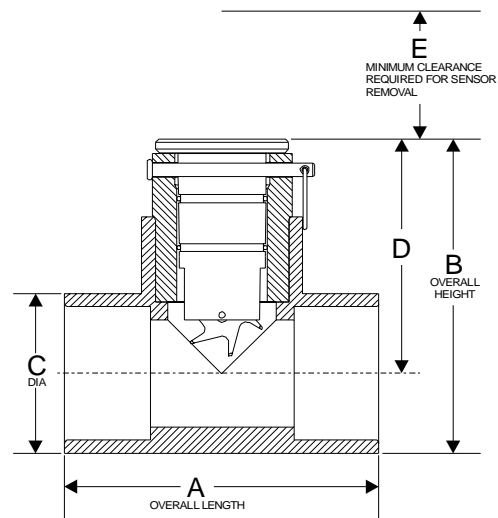

Series No. Complete	I-220PV1500-1211	I-220PV2000-1211	I-220PV3000-1211	I-220PV4000-1211
A	5.0" (127mm)	5.63 (143mm)	6.50" (165mm)	7.38" (187mm)
B	5.16" (131mm)	5.64" (143mm)	6.83" (173mm)	6.83" (199mm)
C	2.38" (60mm)	2.88" (73mm)	4.23" (107mm)	5.38" (137mm)
D	3.97" (101mm)	4.20" (107mm)	4.68" (119mm)	5.10" (130mm)
E	5.0" (127mm)	5.0" (127mm)	5.0" (127mm)	5.0" (127mm)

Not a controlled document.