

The Series I-340 Btu transmitter is an economical, compact device for sub-metering applications.

The I-340 calculates thermal energy by measuring liquid flow in a closed pipe system and measuring temperature at the inlet and outlet points. The I-340 requires two 10 kΩ thermistors for temperature input. The flow input may be provided by any pulse or sine wave signal flow sensors.

The onboard microcontroller and digital circuitry make precise measurements and produce accurate drift-free outputs. The I-340 is programmed using Windows® based software and an I-A301 programming cable. Calibration information for the flow sensor, units of measurement and output scaling may be downloaded prior to installation or in the field. While the unit is connected to a PC or laptop computer, real-time flow rate, flow total, both temperature readings, energy rate and energy total are available.

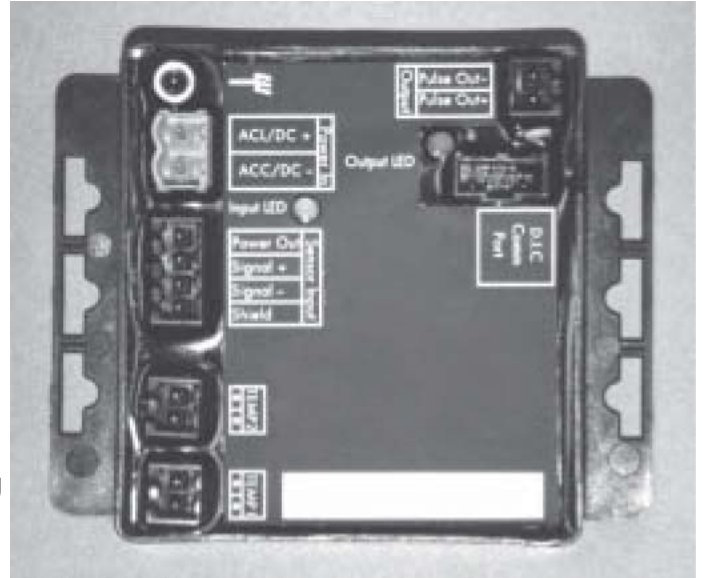

		<b>EXAMPLE:</b>   I-340   -   xx
<b>SERIES</b>	Btu Transmitter	I-340
<b>OPTIONS</b>	Transmitter Only	00
	W / Metal Enclosure	02
	W / Plastic Enclosure	03
	W / DIN Rail Mounting Clips	04

**Transmitter Only**

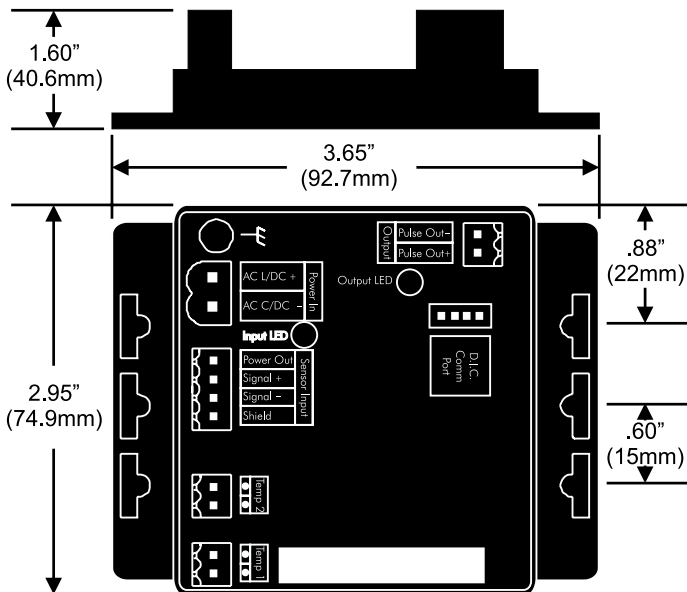

to verify input and output signals.

The standard output for the Series I-340 is an isolated solid state switch closure that is user programmed for units of energy. The output pulse width is adjustable from 50 mS to 5 seconds.

The Series I-340 Btu transmitter operates on AC or DC power supplies ranging from 12 to 24 volts

The compact cast epoxy body measures 3.65"(93mm) x 2.95"(75mm) and can be easily mounted on panels, DIN rails or enclosures.

## Specifications

### Power

Power supply options:

12-24 VAC

12-24 VDC

Current Draw:

60 mA @ 12 VDC

### Flow Sensor Input

All sensors:

Excitation voltage 3 wire sensors:  
7.9 – 11.4 VDC 270Ω source  
impedance

Pulse type sensors:

Signal amplitude:  
2.5 VDC threshold

Signal limits:

$V_{in} < 35V$  (DC or AC peak)

Frequency:

0-10kHz

Pull-up:

2 kΩ

Sine Wave Sensors:

Signal amplitude:

10 mV p-p threshold

Signal limits:

$V_{in} < 35V$  (DC or AC peak)

Frequency:

0-10kHz

### Temperature Sensor Input

2 required:

10 kΩ thermistor, 2 wire, type II,

10 kΩ @ 25°C

### Pulse Output

Pulse Width:

Programmable from 50 mS to 5 Sec  
in 50mS increments

Pulse frequency:

Max of 10Hz @ 50mS pulse width  
programmable to scaling require-  
ments of connected device

Opto-isolated solid state switch

Operating Voltage range:

0 - ±60V (DC or AC peak)

Closed(on) state:

Load Current - 700mA max. over  
operating temperature range

On-resistance - 700mΩ max. over  
operating temperature range

Open(off) state – leakage @ 70°C

<1μA @ 60V (DC or AC peak)

### Operating Temperature

-29° C to +70° C

-20° F to +158° F

### Storage Temperature

-40° C to +85° C

-40° F to +185° F

### Weight

4.8 oz. With headers  
installed

### SENSOR CALIBRATION

Use "K" and "offset"  
provided in sensor  
owner's manual

### Other Sensors

Check with factory

### UNITS OF MEASURE

#### Flow measurement

Rate:

gpm, gph, l/sec, l/min, l/hr,  
ft3/sec, ft3/min, ft3/hr, m3/  
sec, m3/min, m3/hr

Total:

gallons, liters, cubic feet,  
cubic meters

#### Energy measurement

Rate

kBtu/min, kBtu/hr, kW, MW,  
hp, tons

Total

Btu, kBtu, MBtu, kWh, MWh,  
kJ, MJ

#### Temperature Units

Fahrenheit, Centigrade

### PROGRAMMING

Requires PC or laptop running  
Windows® 9x, ME, NT, 2000,  
XP

I-A-340 programming kit  
containing software and I-A301  
programming cable

### Plastic Enclosure Dimensions

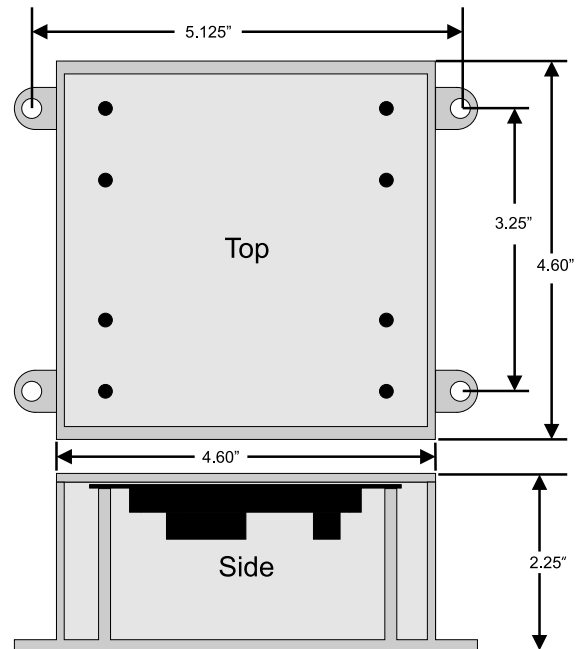

### Metal Enclosure Dimensions

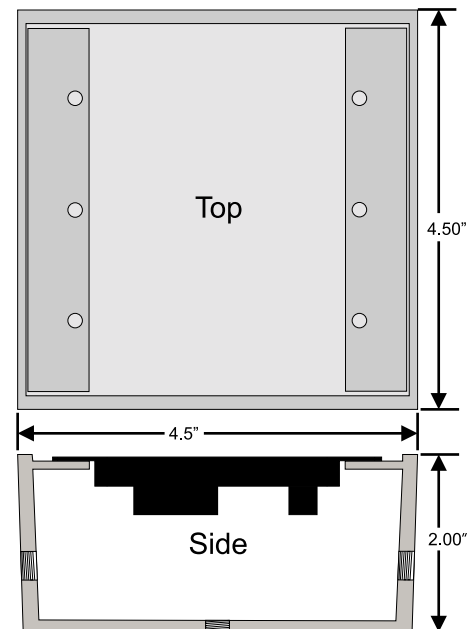

Not a controlled document.