

# Infrared Refrigerant Leak Transmitters & Monitors



Smart II  
IIR-FD-R

## DESCRIPTION

Analog and digital, RS-485 communicating, addressable infrared sensors/transmitters and monitors with relay outputs for the detection of refrigerant in the ambient air.

## APPLICATION

To detect trace amounts of refrigerant gases in commercial applications, such as mechanical and chiller rooms, ventilation in-situ warehouse refrigerator/freezer systems. Transmits its information to any compatible electronic analog or digital MODBUS controller, DDC/PLC, or automation system, and for direct daisy-chain/multi-drop link to the IQ4C/IM controllers in accordance with ASHRAE standards.



NRTL  
"Pending"

## FEATURES

- Continuous monitoring
- 4-20 mA/2-10 VDC analog signal
- RS-485 serial communication output OptoMux or MODBUS, selectable
- Three (3) relay outputs:
  - Three stage control
  - Fail-safe assignable
- Infrared, gas-specific sensing technology, long-life, and temperature compensated
- R11, R22, R123, R134a, R404, R407C, R410A, R507, and many more
- Operates at sub-freezing temperatures
- Liquid Crystal Display (LCD)
- LED status indicators
- Built-in buzzer
- Simple, menu-driven non-intrusive calibration
- Fuse protected
- Easy maintenance
- NEMA 4X enclosure
- 2-year warranty

## SPECIFICATIONS

|                           |   |                               |   |
|---------------------------|---|-------------------------------|---|
| <b>Electric</b>           |   | <b>Sensor life expectancy</b> |   |
| Power Supply              | 24 VAC (15-24 VAC), floating, 50/60 Hz; or 24 VDC (18-30 VDC)               | - IR sensing element          | Min. 10 years   |
| Protection                | Two (2) fuses, polyswitch type (1x1.6 A and 1x50 mA)                        | - IR source                   | Min. 5 years, field replaceable   |
| Power Consumption         | 1.0 A (28 VA), max.   | Sensor coverage               | 2,000 sq. ft., max. 5,000 sq. ft. (186 m <sup>2</sup> , max. 464 m <sup>2</sup> ), under "ideal conditions"                   |
| <b>Sensor Performance</b> |   | <b>Installation Location</b>  |   |
| Gas detected              | Refrigerants<br>Refer to section: "Ordering Information"                    | Location                      | Below chiller, within 5 - 6 feet (1.5 - 1.8 m)  |
| Sensor element            | Beam absorption infrared, gas sampling cell, w/constant temperature control | Mounting height               | 0.5 - 1.0 ft. (0.16 - 0.31 m), above floor (air sampling intake downwards)  |
| Gas sampling method       | Diffusion or pump through   | <b>Type of Control</b>        |   |
| Range                     | 0-100 ppm for R123, 0-1000 ppm for other refrigerants factory calibrated    | General                       | Continuous proportional analog signal, digital communication, and binary/relay three-stage control; i.e. Low-med-high (fault) |
| Resolution                | 1 ppm   | Analog output                 | (1) 4-20 mA, max. impedance 600 Ω, or 2-10 VDC; min. impedance 20 kΩ, jumper selectable                                       |
| Accuracy                  | ± 3 % of reading  | Digital output                | (1) RS-485 serial communication; OptoMux protocol for IQ4 or IM controllers, or MODBUS protocol; selectable                   |
| Repeatability             | ± 1 % of full scale   | Binary/relay outputs          | (3) SPDT, 125 VAC/0.3 A, 30 VDC/1.0 A   |
| Output drift              | Max. 2% of full scale/year  |                               |   |
| Response time             | < 90 sec. to 90% of step change   |                               |   |
| Calibration               |   |                               |   |
| - interval recommended    | 12 to 18 months   |                               |   |
| - adjustment              | Simple 2-point settings, applying calibration gas standards                 |                               |   |

## SPECIFICATION

### Type of Control (Cont...)

|   |  |
|---|--|
| - stage level/setpoint                  | Adjustable for each relay over full sensor range   |
| - hysteresis/<br>switching differential | Selectable for each relay  |
| - relay assignment<br>and configuration | Independent, individually set to be enabled/disabled, not-normally/ normally energized (fail-safe), or latched |
| - time delay switching                  | Selectable for make and brake of each relay, 0-990 seconds   |
| Audible Alarm                           | Built-in buzzer, 80db @ 4 inches (100 mm), 2700 Hz, assignable to any relay/stage level                        |
| - buzzer setting                        | Selectable for double-tap intermittent, intermittent 50% duty cycle, or continuous sound                       |
| Alarm acknowledgement                   | Menu-driven and reset function for latched relays  |

### User Interface

|                                    |   |
|------------------------------------|---|
| Keypad type                        | Refer to "illustration magnetic-touch, menu-driven, keypad user interface"                    |
| - magnetic-touch<br>tool accessing | (4) keys w/magnetic-touch sensors   |
| Status indicators                  | (3) Red LED's for status of relays 1 to 3<br>(2) Green LED's for RS-485 communications status |
| Digital display                    | Liquid Crystal Display (LCD)<br>two lines, 2 x 8 characters with backlight                    |
| - scroll rate                      | Adjustable, 1-9 seconds   |
| - display                          | Transmitter address, gas type, concentration and alarm status                                 |

### Programming

|                         |  |
|-------------------------|--|
| Addressing digital mode | Through menu on display and manual operation of the magnetic-touch keypad user interface |
| Addressing digital mode | Network address number assignment via magnetic-touch key entry                           |
| Addresses available     | Four (#0 to #3) for IQ4 controllers<br>Thirty-two (#0 to #31) for IM controllers         |

### Environmental

|                        |                                |
|------------------------|--------------------------------|
| Permissible ambient    |                                |
| - working temperature  | -49°F to 149°F (-45°C to 65°C) |
| - storage temperature  | -49°F to 158°F (-45°C to 70°C) |
| - humidity, continuous | 5 to 95% RH, non-condensing    |

### Physical

|            |  |
|------------|--|
| Enclosure  |  |
| - material | Polycarbonate, fire-retardant, UL94-5V |
| - color    | Cool gray, front cool gray/black       |
| - cover    | Snap-on, secured by (4) screws         |

### Physical (Cont...)

|                    |   |
|--------------------|---|
| - protection       | NEMA 4X (IP66)  |
| - installation     | Wall (surface) mounted  |
| Dimensions (HxWxD) | 4.73 x 7.87 x 3.54 in.<br>(120 x 200 x 90 mm)                             |
| Cable entry        | 1 hole for ½ in. conduit for wall (surface) mounting                      |
| Wire connection    | Terminal Blocks<br>screw type for lead wire                               |
| Wire size          | Min. 24 AWG (0.25 mm <sup>2</sup> )<br>Max. 12 AWG (4.0 mm <sup>2</sup> ) |
| Weight             | 1.5 lbs. (0.7 kg)   |

### Approvals / Listings

CSA, NRTL C/US, C22-205  
"Pending"

### Warranty

24 months material and workmanship

**ORDERING INFORMATION**

IIR-FD-R xxx

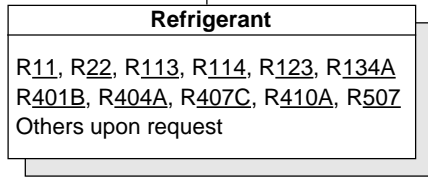

Sample ordering part number:

**IIR-FD-R134A**

Infrared refrigerant leak transmitter, 0-1000 ppm R134a range, 4-20 mA/2-10 VDC output signal and RS-485 serial communication, (3) SPDT relay outputs, menu-driven keypad user interface, LCD & LED, audible alarm, power supply 24 VAC or 24 VDC, NEMA 4X enclosure.

**FIELD WIRING CONFIGURATION**

IIR-FD-R

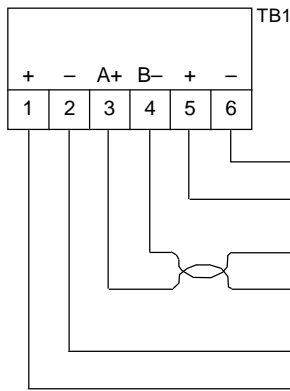

- (-) Return/Com } 4-20 mA, or 2-10 VDC
- (+) Signal } 4-20 mA, or 2-10 VDC
- (B) } RS-485 Digital communication link: Cable, twisted, balanced shielded pair; with characteristic impedance of 120 Ω, e.g. Belden 9841
- (A) } RS-485 Digital communication link: Cable, twisted, balanced shielded pair; with characteristic impedance of 120 Ω, e.g. Belden 9841
- (-) Com } Power supply 24 VAC, floating\*\*, or 24 VDC\*
- (+) } Power supply 24 VAC, floating\*\*, or 24 VDC\*

\*\* Do not connect 24 VAC to earth ground

\* Do not use VDC power supply from the IM controller; use separate VDC power

**J5 Jumper Selector, Analog Output Signal**

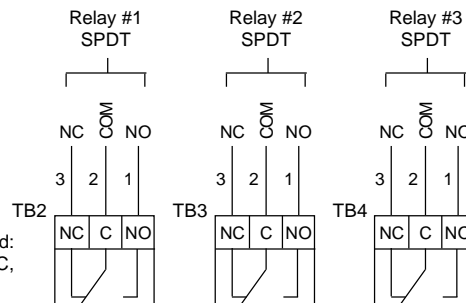
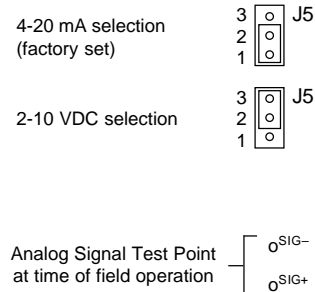

**FIELD WIRING CONFIGURATION (cont...)**

Suggested daisy-chain powering

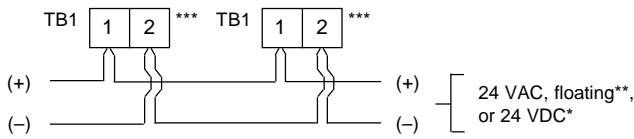

Suggested daisy-chain (multi-drop) communication between transmitters and controller

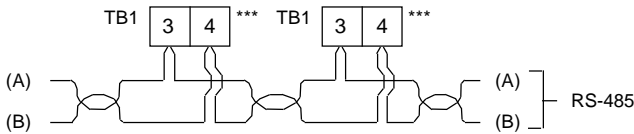

**J3 Jumper Selector, RS-485 End-of-Line Terminator**

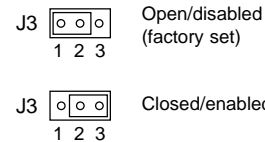

*Only the last transmitter, away from the IQ4 or IM controller, of the communication trunk should enable the End-of-Line Terminator*

\*\*\* Maximum of (4) transmitters can be linked to an IQ4 controller, and (32) transmitters can be linked to an IM Controller

- Note:
- Do not connect power to **A** and **B**; this will damage all transmitters linked on the same daisy-chain trunk.
  - Daisy-chain between transmitters and controller **A to A, B to B**. Do not cross **A to B**; this creates a malfunction of communication.
  - Daisy-chain trunk length between transmitter and controller
    - RS-485 communication up to 3,000 ft. (914 m) max.
    - Powering from controller, w/(4) refrigeration transmitters, up to max. 200 ft. (60 m)/18 AWG wire, or up to max. 300 ft. (91 m)/16 AWG wire.
  - Do not use high voltage lines in the same RS-485 communication cable conduit.

**F1 Fuse**

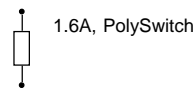

**F2 Fuse**

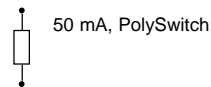

Note:

*“Polyswitches reset after fault is cleared and circuit power switched off.”*

**RS-485 Communication selection, Addressing, and Calibration**

Manually operated using the keypad user interface; refer to user manual.

RS-485 communication output protocol selection via submenu “1\_System Setting”

- OptoMux for IQ4C or IM controllers
- or
- MODBUS for applicable controllers

Sensor/transmitter addressing via submenu “1\_System Setting”

- IQ4 Controller : Addresses 0 to 3
- IM Controller : Addresses 0 to 31
- MODBUS Controller: Addresses 0 to 255

Sensor calibration via submenu “2\_Zero Cal” and “3\_Span Cal,” two-point zeroing/span settings, applying calibration gas standards.

**USER INTERFACE**

**Keypad User Interface**

Digital Display      Communication Green LED's\*



Relay Status Red LED's

Magnetic-touch Keypad

\* RS-485 communication traffic status LED's between transmitter and remote controller

**Keypad Menu Tree**

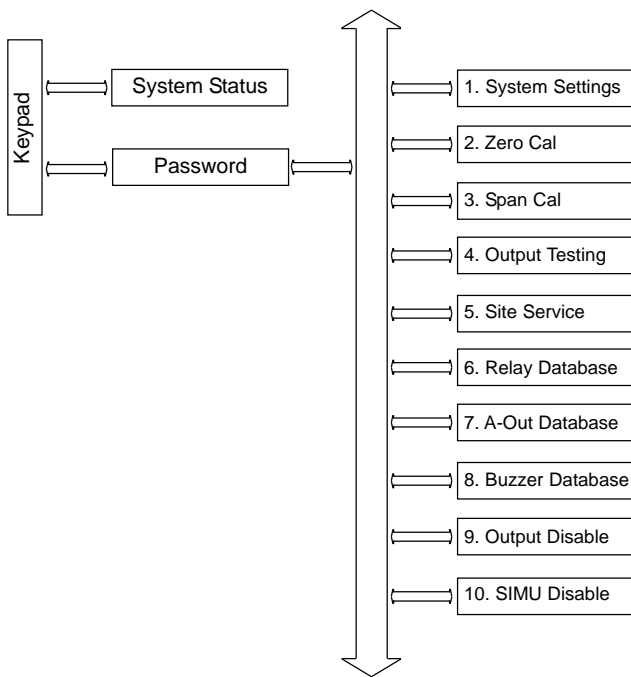

**System Operation**

Programming can be made via the keypad user interface in combination with the display screen. Security is provided via a four-digit password.

**Main Page Display**

Displays current sensor reading and output.

**Main Menu**

Displays headings of "1\_System Setting," "2\_Zero Cal," "3\_Span Cal," "4\_Output Testing," "5\_Site Service," "6\_Relay Database," "7\_A-Out Database," "8\_Buzzer Database," "9\_Output Disable," and "10\_SIMU Disable."

**Sub Menu "1\_System Setting"**

Enter and/or change system parameters

- Address (003)
- Baudrate (4800 bps)
- Scroll (3 sec)
- Backlite (ON)
- 4mA Cal (144)
- 20mA Cal (905)
- Change Password
- Protocol (OptoMux or MODBUS)
- Gas Type
- Auto Zero
- Restore at Default
- Spec Gas

**Sub Menu "2\_Zero Cal"**

Transmitter provides Local Zeroing

**Sub Menu "3\_Span Cal"**

Transmitter provides Local Spanning

**Sub Menu "4\_Output Testing"**

Force relay, buzzer and strobe actions

- Relay Test
- Buzzer Test
- A-Out Test

**Sub Menu "5\_Site Service"**

(Factory Service Staff use only)

**Sub Menu "6\_Relay Database"**

- Assign (de-energized or energized) normal operation
- Assign with latching or non-latching
- Assign ON/OFF Levels
- Assign DELAY ON/OFF Time (in seconds)
- Assign Fault
- Assign Window

**Sub Menu "7\_A-Out Database"**

- Assign Concentration at 4 mA
- Assign Concentration at 20 mA

**Sub Menu "8\_Buzzer Database"**

- Assign (de-energized or energized) normal operation
- Assign with latching or non-latching
- Assign ON/OFF Levels
- Assign DELAY ON/OFF Time (in seconds)
- Assign Fault
- Assign Window

**Sub Menu "9\_Output Disable"**

All outputs can be disabled/enabled for test and calibration.

**Sub Menu "10\_SIMU Disable"**

Simulation mode for test and calibration.