

DESCRIPTION

Wall-mounted, digital RS-485 communicating relay modules for direct daisy-chain/multi-drop link to the IM digital controller.

APPLICATION

To control remotely installed addressable relays via the RS-485 digital bus of the IM controller.

FEATURES

- *RS-485 serial communication*
- *Up to (8) DPDT relays*
- *Lockable enclosure*
- *LED status indicators*
- *Easy programming*

IM-RELAY



SPECIFICATIONS

Electric

Power supply 24 VAC (12-28 VAC), floating, 50/60 Hz, 24 VDC (15-40 VDC)
 Protection Fuse, 2 A

Power consumption

- w/(2) relays 2.4 VA (100 mA)
 - w/(4) relays 3.6 VA (150 mA)
 - w/(6) relays 4.8 VA (200 mA)
 - w/(8) relays 6.0 VA (250 mA)

Type of Control

General Two to eight DPDT relay outputs controlled by a remote IM controller

Input signal for serial communication Digital, RS-485, proprietary protocol
 Relay outputs DPDT, 5(3.7) A 240 VAC / 30 VDC

Environmental

Permissible ambient
 - working temperature -4°F to 122°F (-20°C to 50°C)
 - storage temperature 32°F to 104°F (0°C to 40°C)
 - humidity, continuous 15 to 90% RH, non-condensing
 - humidity, intermitted 0 to 99% RH, non-condensing
 - working pressure Atmospheric ± 10%

Physical

Enclosure w/supplied key
 - material Steel case
 - color Epoxy black
 - protection NEMA 1, general purpose
 - installation Wall (surface) mounted

Dimensions (H x W x D) 10.0 x 8.0 x 2.0 in. (254 x 203 x 51 mm)

Cable entry 4 holes for 3/4 in. conduit, covered

Wire connection Terminal blocks, screw type for lead wire

Wire size Min. 26 AWG (0.4 mm²), Max. 14 AWG (2.5 mm²)

Weight Max. 3.85 lbs. (1.75 kg)

Approvals / Listings

- relays UL Recognized
 CSA Certified
 VDE, TÜV Approved
Warranty 12 months material and workmanship

ORDERING INFORMATION

Digital relay module, RS-485

IM-RELAY-5-2	w/(2) DPDT 5 A relays
IM-RELAY-5-4	w/(4) DPDT 5 A relays
IM-RELAY-5-6	w/(6) DPDT 5 A relays
IM-RELAY-5-8	w/(8) DPDT 5 A relays

FIELD WIRING CONFIGURATION

TB10 Power Supply 24 VAC or 24 VDC

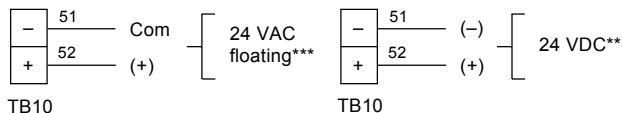

*** Do not connect 24 VAC to earth ground.

** Do not use VDC power supply from the IM controller, use separate VDC power.

F1 Fuse

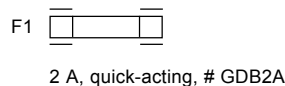

Suggested daisy-chain powering w/wire nuts*

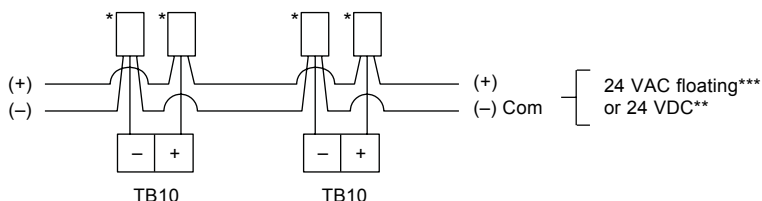

TB9 RS-485 Digital Communication Link

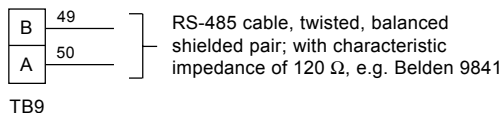

Notes:

- Do not connect power to **A** and **B**, this will damage all relay modules/transmitters and controller linked on the same daisy-chain trunk.
- Daisy-chain between relay modules/transmitters and controller **A** to **A**, **B** to **B**. Do not cross **A** to **B**, this creates malfunction of communication.
- Maximum daisy-chain trunk length is 3,200 ft. (1,000 m).
- Do not use high voltage lines in the same RS-485 communication cable conduit.

Suggested daisy/chain (multi-drop) communication between relay modules/transmitters and controller w/wire nuts*

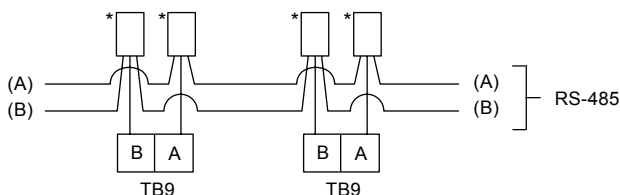

* Max allowable distance between wire nut and RS-485 terminal connection is 9 inches (22.9 cm).

J1 Jumper Selector, RS-485 End-of-Line Terminator

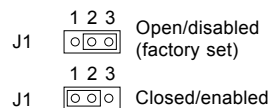

Only the last relay modules/transmitter, away from the IM controller, of the communication trunk should enable the End-of-Line Terminator

FIELD WIRING CONFIGURATION (cont...)

TB1 to TB8* Relay Outputs

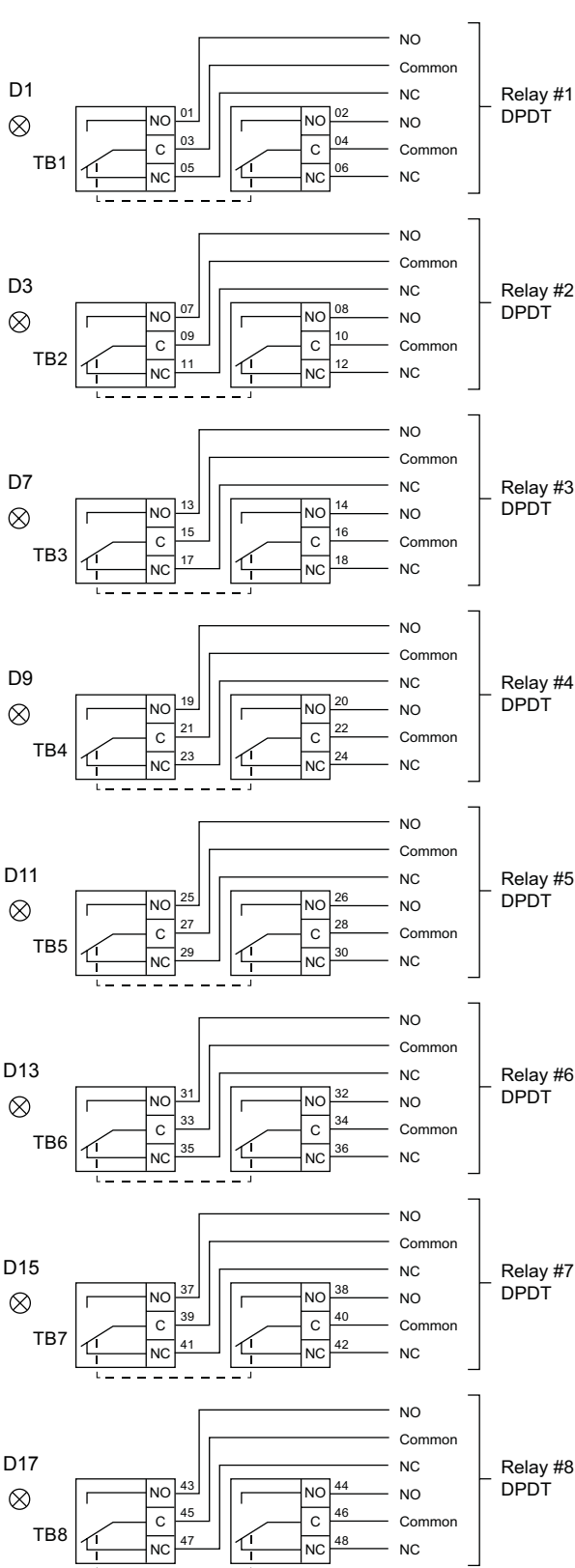

* TB/Relay configurations with part number:
 IM-RELAYS-5-2 = TB1 and TB2
 IM-RELAYS-5-4 = TB1 to TB4
 IM-RELAYS-5-6 = TB1 to TB6
 IM-RELAYS-5-8 = TB1 to TB8

Relays DPDT
 240 VAC / 30 VAC, 5 (3.7) A













⊗ = Relay Status LEDs

PROGRAMMING

S1 Dip Switch Module Address Setting

The RS-485 digital communication network allows maximum (12) IM-RELAY Modules (up to 96 relays) to be linked to one IM controller. Each IM-RELAY Module requires appropriate address setting ("0 to 11").

Note: Duplicating addresses will create a communication malfunction.

Selecting IM-RELAY Module Address (dip switch setting)					
Module address #	** Relay address #	Module address #	** Relay address #	Module address #	** Relay address #
 0	4* to 11	 4	52 to 59	 8	68 to 75
 1	12 to 19	 5	60 to 67	 9	76 to 83
 2	20 to 27	 6	36 to 43	 10	84 to 91
 3	28 to 35	 7	44 to 51	 11	92 to 99
<p>* IM controller's built-in three output control relays to be assigned to relay address 1, 2 and 3</p> <p>** Individual relay addresses are assigned via the IM controller's menu format programming, and appropriately linked to the module address</p>					