



Streamline® Low Profile Mini Strobe

LP1

Model LP1

COMPACT, ECONOMICAL STROBE LIGHT — IDEAL FOR CONTROL PANEL APPLICATIONS

- Easy access dome available in five colors
- Available in 12VDC, 24VDC, 120VAC and 240VAC
- Surface mount
- Low profile — only 2.6" High by 2.33" Wide by 5" Long
- UL Listed, CSA Pending
- Type 4X, IP65 enclosure

The Model LP1 low profile strobe light. This rectangular Type 4X strobe light is available in five colors: amber, blue, clear, green and red. The LP1 is designed to be flush mounted to control panels or other flat surfaces. Mounting is accomplished with two supplied 1¹/₄" 8/32 slotted hex bolts. A polypropylene gasket is supplied to create a water-tight and dust tight seal. The gasket mounts between the base of the light and the mounting surface.

The user replaceable strobe tube is rated for 4,000 hours of life. The LP1 is available in 12VDC, 24VDC, 120VAC and 240VAC versions. The unit is UL Listed. Access to the printed circuit board and strobe tube is provided through the back of the unit.

With its Type 4X rating, small size, and bright signal, the LP1 suits an endless number of applications. The LP1 is especially suited for use on control panels, machines, above entry ways, on walls, and along assembly lines. The 12/24VDC units are suitable in battery backup systems and vehicular applications such as forklifts and moving guided vehicles.

Model	Voltage	Operating Current	Flash Rate/ Minute	Candlepower		Mount
				Peak ¹	ECP ²	
LP1	12VDC	0.18 amps	80	108,000	30	Surface
LP1	24VDC	0.08 amps	80	108,000	30	Surface
LP1	120VAC	0.06 amps	80	108,000	30	Surface
LP1	240VAC	0.03 amps	80	108,000	30	Surface

¹ Peak candlepower is the maximum light intensity generated by a flashing light during its light pulse

² ECP (Effective Candlepower) is the intensity that would appear to an observer if the light were burning steadily

LOW-PROFILE MINI STROBE (LP1)

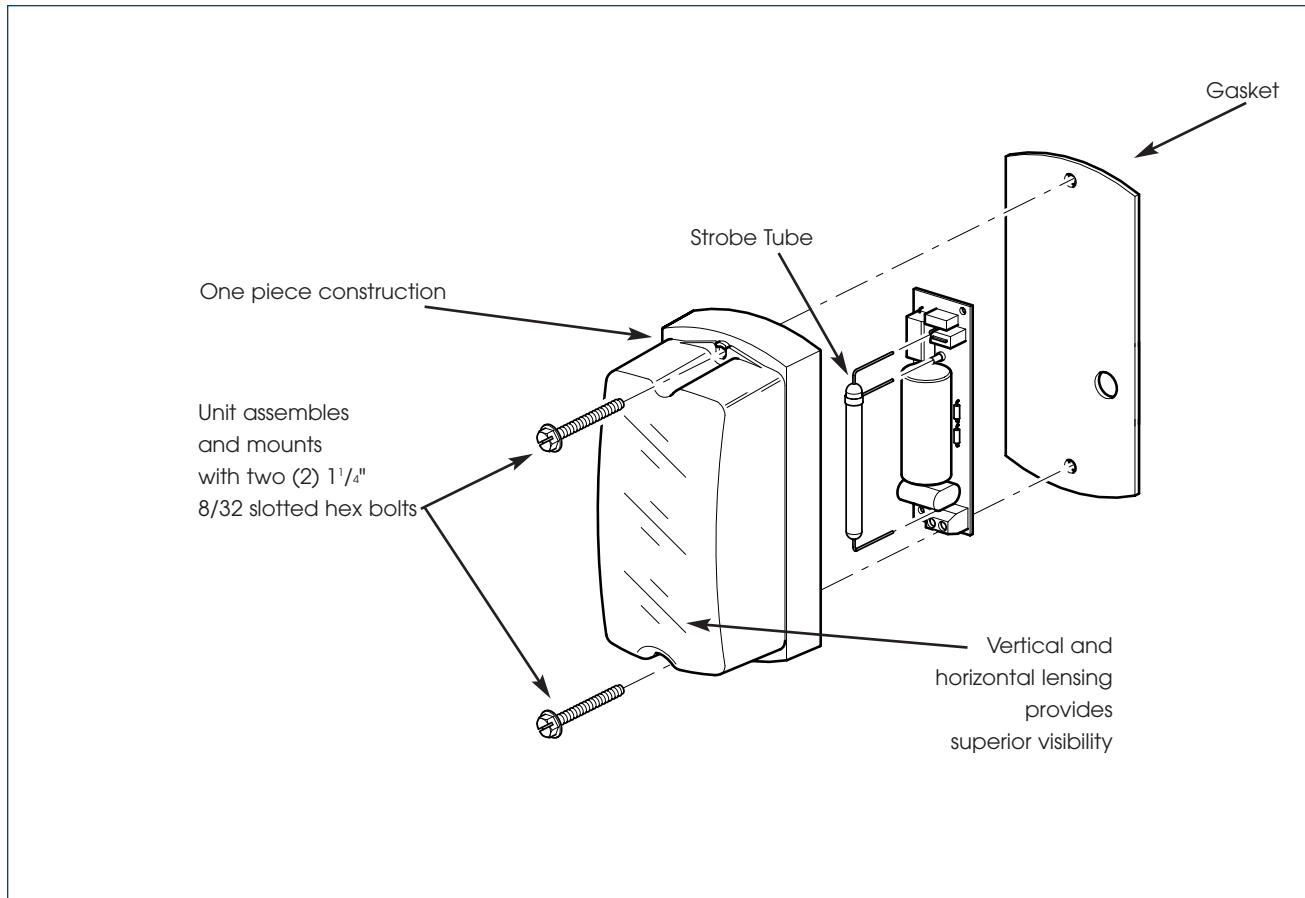

SPECIFICATIONS

Lamp Life:	4,000 hours	4,000 hours
Lamp Style:	Strobe	Strobe
Net Weight:	0.23 lbs.	0.1 kg
Shipping Weight:	0.6 lbs.	0.27 kg
Height:	2.61"	6.63 cm
Width:	2.33"	5.92 cm
Length:	5.05"	12.83 cm

HOW TO ORDER

- Specify model, voltage and color

REPLACEMENT PARTS

<u>Description</u>	<u>Part Number</u>
Replacement Strobe Tube	K149128A
Dome, Amber	K8435711A-02
Dome, Blue	K8435711A-03
Dome, Clear	K8435711A
Dome, Green	K8435711A-04
Dome, Red	K8435711A-01