

MCP-1040/1140/04xx Series

4" Pneumatic Damper Actuators

Description

These actuators are designed to position automatic air dampers in pneumatically controlled systems. The units may be used for gradual or two-position applications.

Models are available with either post or right-angle bracket mounting. Right-angle models are shipped with crank arms for either 1/2" or 3/8" damper shafts. Either style is available with a factory-mounted positive positioner. Actuators with positive positioners include an 8 to 13 psi internal spring and a 5 psi span spring. A 10 psi spring may be ordered separately.



(Clevis and Post Mount Shown)



(Crank Arm and Right Angle Mount Shown)

Features

- ◆ Gradual or two position action
- ◆ Post or right angle mounting bracket
- ◆ Variety of spring ranges, mounting brackets, and linkages provide flexibility

Models

MCP-1 X 40 Y ZZZ

"X" Mounting Brackets

- 0: Right angle mount
- 1: Post mount

"Y" Spring Ranges and Retracted/Extended Torque

(Based on 0 and 20 psi applied, at 90°)

- 1: Non-metallic positive positioner (CMC-1001)
- 2: 3 to 12 psi; 66/176 in. lbs. (21 to 83 kPa; 7/20 N•m)
- 3: 5 to 10 psi; 110/220 in. lbs. (34 to 69 kPa; 12/25 N•m)
- 5: 8 to 13 psi; 176/154 in. lbs. (55 to 90 kPa; 20/17 N•m)
- 6: 10 to 15 psi; 220/110 in. lbs. (69 to 103 kPa; 25/12 N•m)
- 8: 4 to 8 psi; 88/264 in. lbs. (28 to 55 kPa; 10/19 N•m)
- 9: Metallic, positive positioner (CMC-1002)

"ZZZ" Bracket/Linkage

- 520: MCP-1140 with clevis
- 208: MCP-1040 with ball joint
- 211: MCP-1040 with 1/2" crank arm
- 212: MCP-1040 with 3/8" crank arm

Accessories/Replacement Parts

CMC-1001	Non-metallic positive positioner
CMC-1002	Metal positive positioner
MCP-0402	3-12 psi act. for MCP-1040 series
MCP-0403	5-10 psi act. for MCP-1040 series
MCP-0405	8-13 psi act. for MCP-1040 series
MCP-0406	10-15 psi act. for MCP-1040 series
MCP-0408	4-8 psi act. for MCP-1040 series
MCP-0435	8-13 psi Phoenix actuator
MCP-0452	3-12 psi act. for MCP-1140 series
MCP-0453	5-10 psi act. for MCP-1140 series
MCP-0455	8-13 psi act. for MCP-1140 series
MCP-0456	10-15 psi act. for MCP-1140 series
MCP-0458	4-8 psi act. for MCP-1140 series
VTD-0803	Ball joint, 1/4-20 male x 5/16-24" female for end of actuator shafts
VTD-0804	Ball joint, 1/4-20 male x 1/4-20" female for use with VTD-1400 series crank arms
VTD-0902	Right-angle bracket used on right-angle mounted 3" and 4" actuators
VTD-0904	Rear post used on rear swivel mounting of all 3" and 4" actuators, used with VTD-0905
VTD-0905	Offset bracket, used with VTD-0904 for post-mounting of all 3" and 4" actuators

(Accessories and Replacement Parts continued on next page)

Details

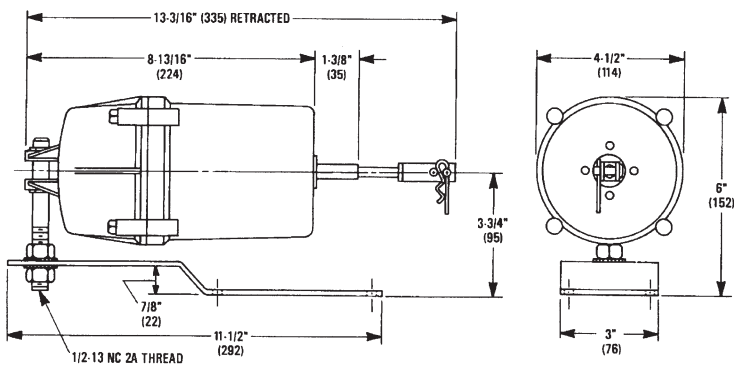

MCP-1140

All dimensions are in inches (mm)

⚠ CAUTION

Pneumatic devices must be supplied with clean, dry control air. Any other medium (e.g., oil or moisture contamination) will cause the device to fail.

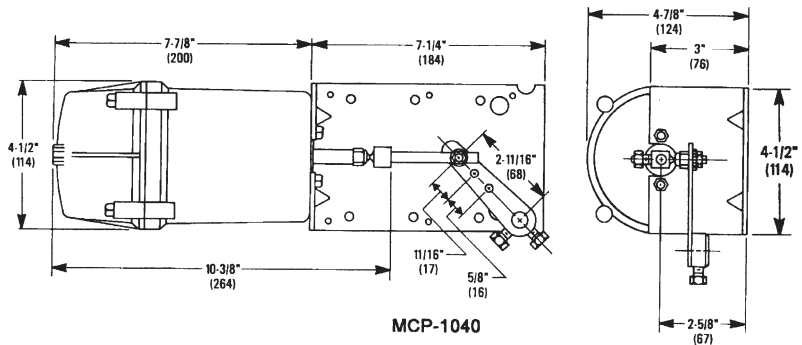

MCP-1040

Specifications

Material

Body	Glass-filled nylon (Nylatron GS63-13)
Diaphragm	Neoprene
Piston	Glass-filled nylon (Nylatron GS63-13)
Shaft	CRS with nickel plating
Bearings	Nylatron GS63-13 glass-filled nylon (but Delrin in the MCP-0435)

Weight

4.5 lbs. (2.04 kg)

Effective Area

11 square inches (71 sq. cm)

Stroke

4 inches (102 mm)

Control Signal Connection

3/16" (5 mm) fitting for 1/4" (6 mm) O.D. polyethylene tubing

Control Signal Pressure Input

0–20 psig (138 kPa) operating
30 psig (207 kPa) maximum

See note under Temperature Limits

Temperature Limits

Operating	–20° to 180° F (–29° to 82° C)
Shipping	–40° to 180° F (–40° to 82° C)

NOTE: If application requires operation near maximum temperature AND maximum pressure, install a tubing restraint at the actuator connection.

Accessories (Continued)

VTD-1100	1/4" clevis pin, post mount
VTD-1205	Hairpin cotter, post mount
VTD-1414	3-hole crank arm, 3/8" shafts
VTD-1415	3-hole crank arm, 1/2" shafts
VTD-1500	Positioner feedback arm
VTD-1634	Push rod, 5/16" X 3-1/4"
VTD-1920	1/2-13 hex nut used on VTD-0904 post
VTD-2101	1/2" ID lock washer used on VTD-0904 post
VTD-2251	5# feedback spring; CMC-1001
VTD-2253	5# feedback spring; CMC-1002
VTD-2261	10# feedback spring; CMC-1001
VTD-2263	10# feedback spring; CMC-1002
VTD-9424	Replacement actuator diaphragm

INTEC
Wilson Mohr

9730 Distribution Ave.
San Diego, CA 92121

Ph: 858-578-7887
Fx: 858-578-4633

Email: info@inteccontrols.com
www.inteccontrols.com