

# Multi-Point Gas Detection and Control System



## DESCRIPTION

Wall mounted, microprocessor-based, multi-point, analog electronic control system for various gas, temperature and humidity detection, control and alarm.

**PolyGard  
MGC2-08**



## APPLICATION

To control and alarm upon the presence of any toxic, combustible and refrigerant gases. Any combination of the AT-11/3300 series or other 4-20 mA transmitters can be connected to the control unit. The controller can interface via binary outputs, a 4-20 mA signal, and an optional BACnet coupler with any compatible electronic analog control, DDC/PLC control or automation system.

## FEATURES

- Continuous monitoring
- Eight (8) analog inputs, 4-20 mA
- Four (4) digital inputs
- Ten (10) relay outputs:
  - Five-stage control
  - Fail-safe assignable
- Four (4) analog outputs, 4-20 mA
  - Selectable for low, high or averaging
- One (1) 24 VDC supply output
- Built-in horn
- Accepts combination of toxic or combustible gases, refrigerants, temperature or humidity sensor inputs
- Liquid Crystal Display (LCD)
- LED status indicators
- Optional BACnet coupler upwards communication to BAS
- Keypad user interface
- Simple menu-driven programming
- RFI/EMI protected
- Modular technology
- Overload & short-circuit protected
- Resettable breaker
- NEMA 4X enclosure
- Easy maintenance



City of Los Angeles Approved



NRTL Tested & Certified  
Conforms to STD  
**UL 2017**

*System performance tested in conjunction with PolyGard Carbon Monoxide & Combustible Gas Transmitters to STD UL 2075*

BACnet Upwards Communication  
Option



## SPECIFICATIONS

<p><b>Electric</b></p> <p>Power supply                    120 VAC (90...230 VAC), 50/60 Hz resettable breaker, 24 VAC on request</p> <p>Power consumption            30 VA, max.</p> <p>RF/EMI protected              4.0 W @ 3 ft. (1 m) radiated</p> <p><b>Type of Control</b></p> <p>General                            Five-stage (S1 to S5) control, assignable up to ten (10) binary/relay output, i.e. Low-med-high-fault/fail-horn*, or low1-low2-med1-med2-high, or any other combinations (* = horn/audible alarm built-in and factory pre-configured to relay output "R10")</p> <p>Analog inputs                    Eight (8) 4-20 mA</p> <p>Analog reading                  Current and mean (average) value</p> <p>Stage level / setpoint           Field adjustable over full range, five (5) per analog input, assignable to current or mean (average) value</p> <p>- hysteresis/ switching differential            Selectable for each sensor point</p>	<p>Digital inputs                    Four (4), each can be individually assigned to any relay (R1...R10). Remote audio/visual alarm reset or override function</p> <p>- application</p> <p>Relay outputs (R1-R10) w/ status LEDs                  Ten (10) SPDT, 8A 24 VAC/VDC-250 VAC contact resistance 100 mΩ, max. Assignable to any relay Assignable to any stage level Selectable for make and brake of each sensor point (SP1 to SP8) 0-9,999 seconds</p> <p>- each stage level (S1-S5)</p> <p>- sensor fail-safe</p> <p>Time delay switching</p> <p>VDC output supply              24 VDC, 0.5 A fused</p> <p>Analog output                    Four (4) independent 4-20 mA signal, 500 Ω max. load, selectable as low, high or averaging of sensor inputs</p> <p>Audible alarm                    85 db (10 ft), enabled or disabled, selectable; assignable to stage level S1, S2, S3, S4 or S5</p> <p>Alarm acknowledgement        Menu-driven and system reset function for latched relays</p>
---	--

**SPECIFICATION**

**User Interface**

Keypad type	Refer to "illustration keypad user interface"
Touch buttons	Six (6)
Status LED's	Yellow: Fault (fail) Red: Alarm
Digital display	Liquid Crystal Display (LCD), two lines, 16 characters per line, 1 digit resolution, backlit
- unit display	Menu selectable, per sensor; ppm, %v/v, %LEL, °F or % RH

**BACnet Interface, optional\***

	Read status information via BACnet coupler and BACnet-Profile, BACnet-Services and BACnet BIBBs
Input scaling	Coupler option "B"
0-250 ppm CO	Coupler option "P"
0-100%	
Communication	TCP/IP 10/100 Mbits/sec
Connector	Ethernet RJ45
Interface	BACnet-Profile
Description	BACnet-Services "Who-is (execute)" "I-am (initiate)" "ReadProperty" "WriteProperty"
Object types	Version B1.2, B2.2

**Environmental**

Permissible ambient	
- working temperature	23°F to 104°F (-5°C to 40°C)
- storage temperature	-4°F to 104°F (-20°C to 40°C)
- humidity	15 to 95% RH, non condensing
- working pressure	Atmospheric ± 10%

**Physical**

Enclosure (panel)	
- material	Polycarbonate, impact resistance EN 50102/IK08, flammability rating UL 94-5V
- conformity	UL Type 1, UL508/UL 50 standards
- color	Light gray, smoked gray for cover
- protection	NEMA 4X (IP65)
- installation	Wall (surface) mounted
Dimensions (H x W x D)	
- base	11.0 x 12.0 x 5.7 in. (280 x 306 x 145 mm)
Cable entry	10 holes for 1/2 in. conduit, covered
Wire connection	Terminal blocks, Push-on connect and screw type for lead wire
Wire size	
- input	Min. 22 AWG (0.34 mm <sup>2</sup> ) Max. 16 AWG (1.50 mm <sup>2</sup> )
- output	Min. 24 AWG (0.25 mm <sup>2</sup> ) Max. 14 AWG (2.50 mm <sup>2</sup> )
Weight	10.0 lbs. (4.5 kg)

**Approvals / Listings**

- unit rating	NRTL Performance Tested & Certified Conforms to ANSI/UL 2017 City of Los Angeles CE VDI 2053, C-No. 418791 EMV-Compliance 89/336/EWG UL Listed, E75645
- enclosure (panel)	Two years material and workmanship

**Warranty**

**ORDERING INFORMATION**

**MGC 2 - 08 - 1000 US**

Option	
00	No options
01	Key Lock w/2 keys
B0	BACnet Upwards Communication Coupler "C5-BAC-98" for AT Transmitters (0-250 ppm CO)
P0	BACnet Upwards Communication Coupler "C5-BAC-98-1" for AT Transmitters (0-100%)

Standard control system, ordering part number:

**MGC2 - 08 - 1000 US,**  
configuration includes:

Digital, programmable controller with menu-driven key-pad user interface, LCD & LEDs, 120 VAC (90...250 VAC) 50/60 Hz, NEMA 4X enclosure

Inputs: (8) 4-20 mA  
(4) Digital

Outputs: (10) Relays, SPDT, 8A  
(4) 4-20 mA  
(1) 24 VDC, 0.5A

(\* ) BACnet Interface: NRTL Certification to UL STD 61010-1 – "Pending"

**USER INTERFACE & CONTROLLER**

**Keypad User Interface**

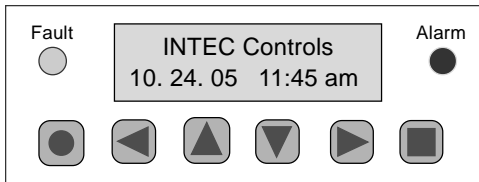

- Fault "Yellow LED" Flashes at system / sensor failed
- Alarm "Red LED" Flashes when any stage level setpoint is exceeded; steady when any relay output is in manual override operation
- Scroll down & up in Main menu and Sub menus; increases or decreases a value
- Navigates through menus on the same level; moves cursor when inputting data
- Exits programming and saves settings or return to previous level or menu
- Enter Sub menus or stores data; horn silence (if assigned)

**Main Page & Main Menu**

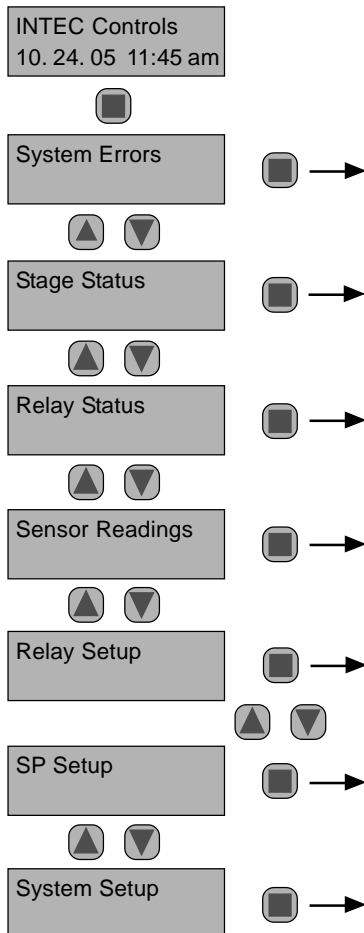

**System Operation**

All Programming is made via the keypad user interface in combination with the display screen. Security is provided via two password levels. The lower level password allows to override or to reset system status functions. The upper level password allows all programming and override functions.

**Main Page Display**

After powered on, displays INTEC and part number and changes to sensor reading display unless a system error occurs; then the error is displayed.

**Main Menu**

Displays headings of "System Errors", "Stage Status", "Relay Status", "Sensor Readings", "Relay Setup", "SP (Sensor Point) Setup", and "System Setup".

**Sub Menu "System Errors"**

Displays errors, reset corrected errors, and historical error summary.

**Sub Menu "Stage Status"**

Displays status of each "SP" sensor point, stage level/ setpoint exceeded.

**Sub Menu "Relay Status"**

Displays status and manual control of each output relay.

**Sub Menu "Sensor Readings"**

The current and mean/average values are displayed for each "SP" sensor point with sensing type and engineering unit (ppm, %v/v, %LEL, F, %RH).

**Sub Menu "Relay Setup"**

Enter and /or change parameters of each relay.

- Assign de-energized or energized normal operation
- Select steady or flashing function
- Select horn function
- Select latching or non-latching mode
- Select digital input usage, and assign to any output relay

**Sub Menu "SP Setup"**

Enter and/or change parameters of each sensor point.

- Activate sensor point
- Select sensor point type (gas, temperature, humidity)
- Select measuring range
- Select sensor signal
- Select stage/setpoint 1 to 5
- Select hysteresis
- Set delay ON/OFF time
- Select current or mean/average value
- Assign sensor point fault to stage level setpoint
- Assign setpoint 1 to 5 to any output relay
- Assign to analog Output

**Sub Menu "System Setup"**

Enter and/or change system parameters.

- Select service mode
- Set next maintenance date
- Select service phone number
- Select averaging function, time and overlay, of any SP
- Set date, time and time format
- Change customer password
- Select analog output function
- Set failure relay
- Select power ON time
- Select appropriate hardware configuration

**FIELD WIRING CONFIGURATION**

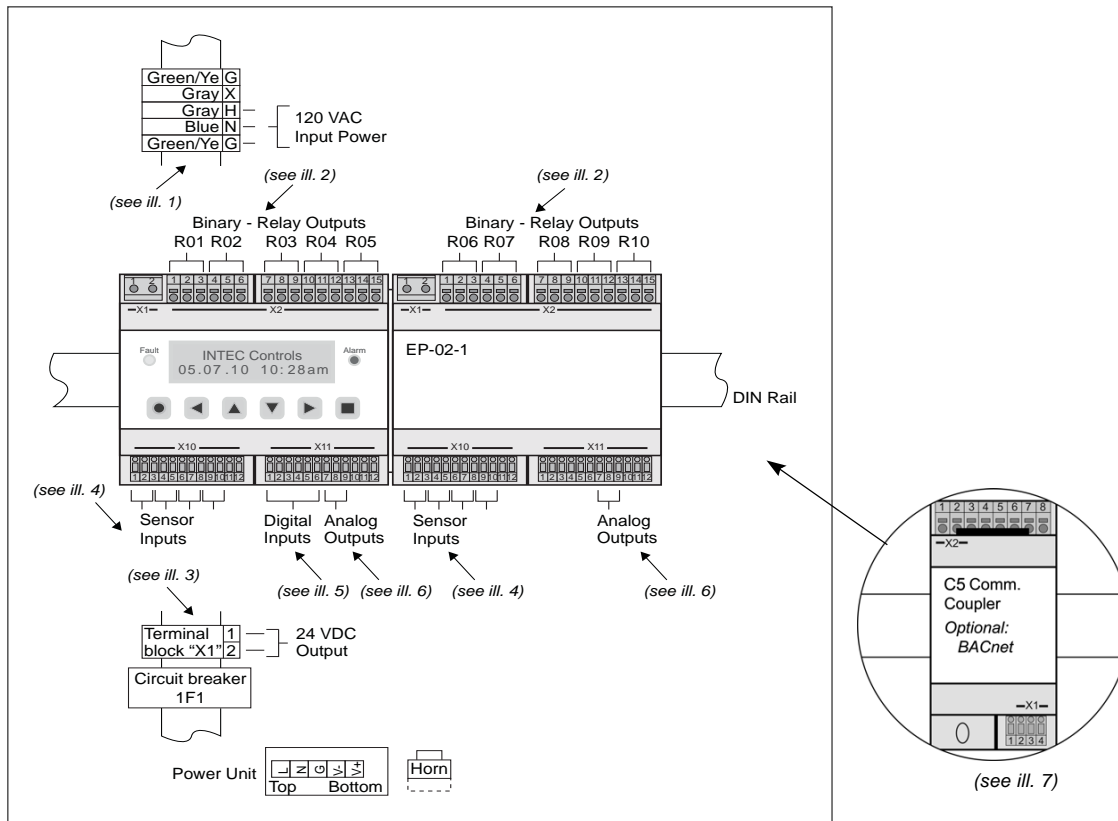

**Recommended**

- **Twisted, shielded wire for analog inputs**  
(Shield to be terminated and connected only at the sensor/transmitter location)
- **Grounded housing**

**Caution:**

The non-metallic enclosure does not provide grounding between conduit connections. Use grounding bushings and jumper wires.

The enclosure is to be mounted using the mounting holes located in the base external to the equipment cavity, or the equivalent.

The conduit hubs must be connected to the conduit before connected to the enclosure.

When connecting conduit to the enclosure use only UL listed or UL recognized conduit hubs that have the same environmental type rating as the MGC2-08 enclosure.

ill. 1

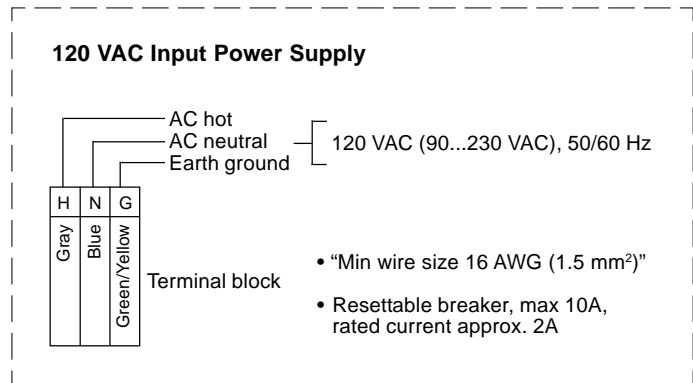

ill. 7

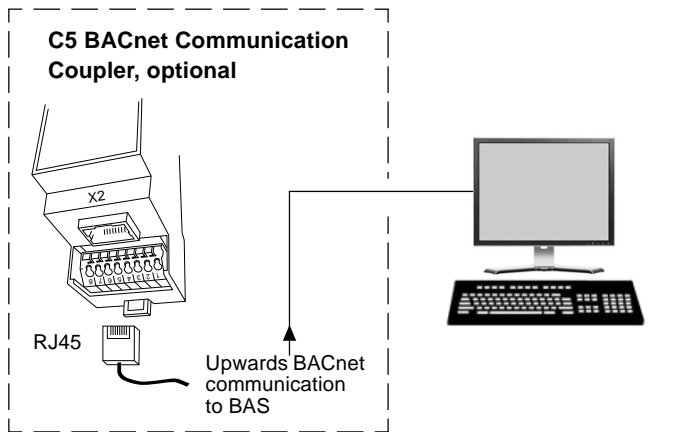

FIELD WIRING CONFIGURATION (cont...)

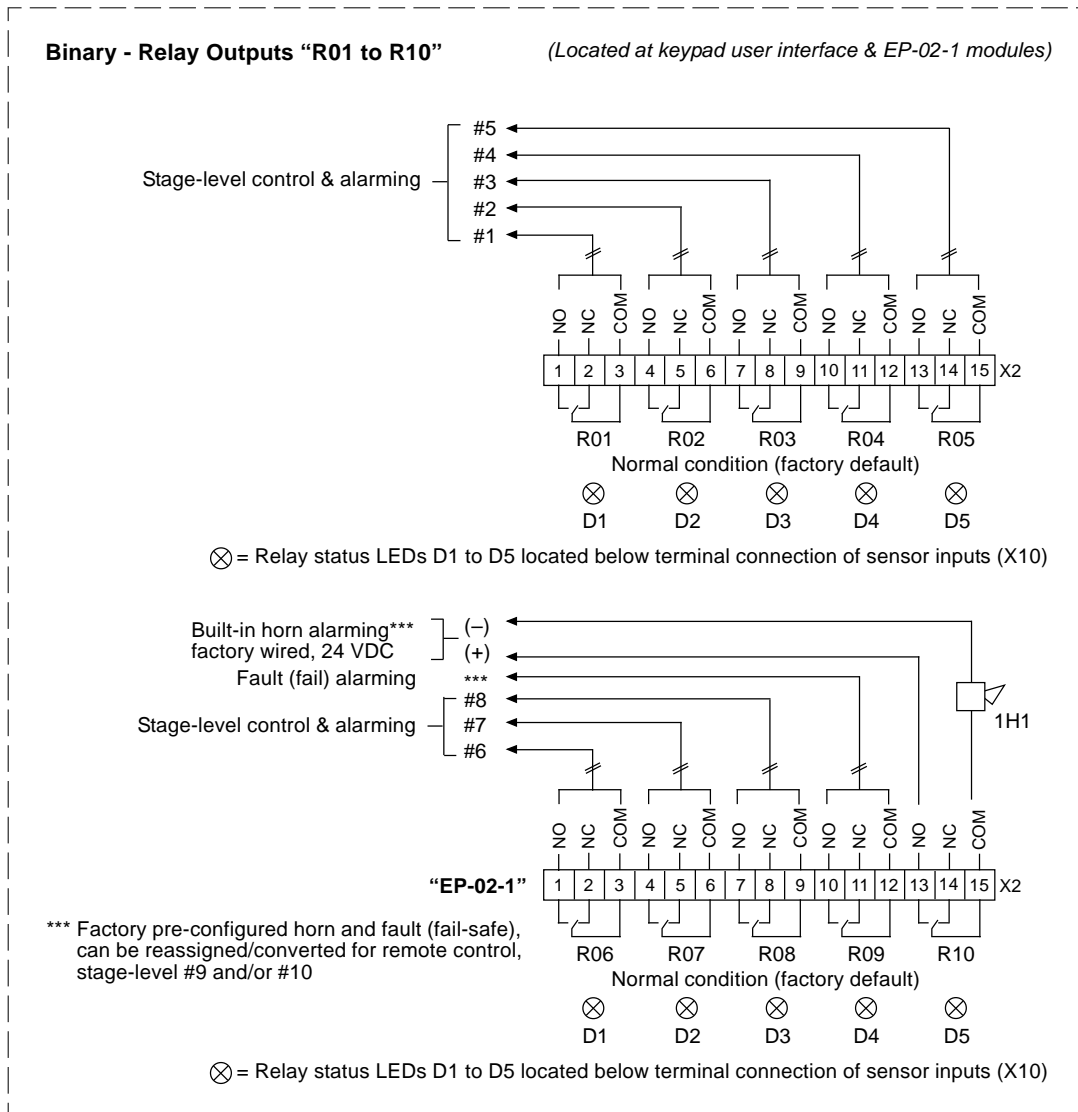

ill. 2

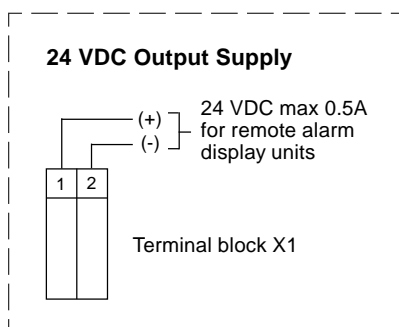

ill. 3

**FIELD WIRING CONFIGURATION (cont...)**

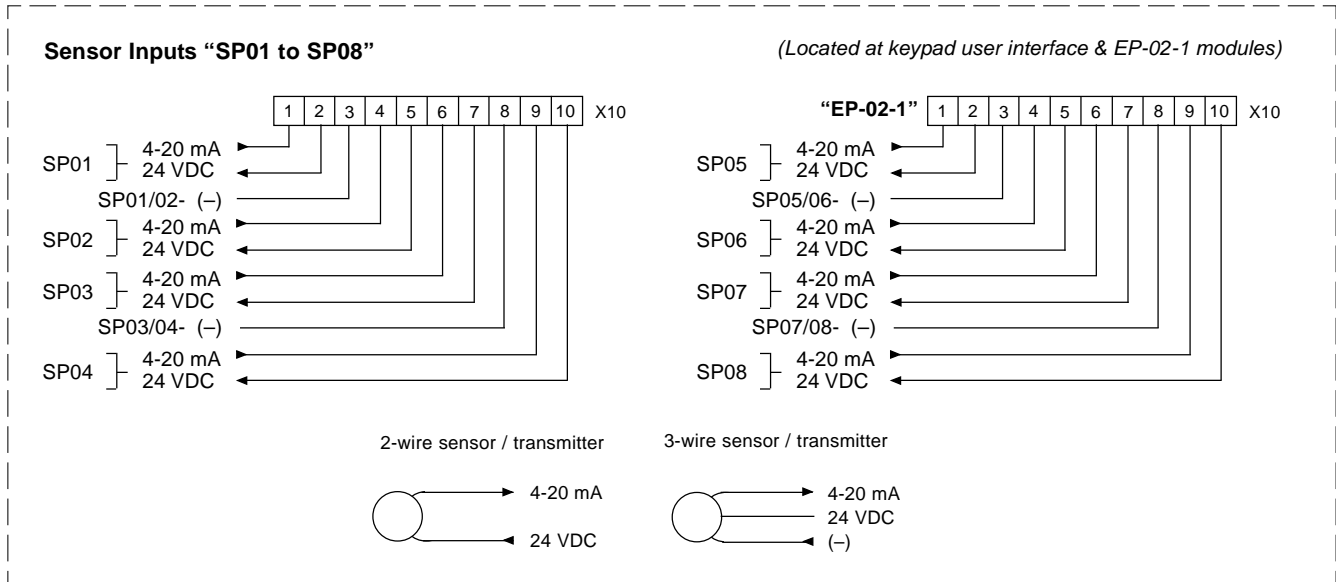

ill. 4

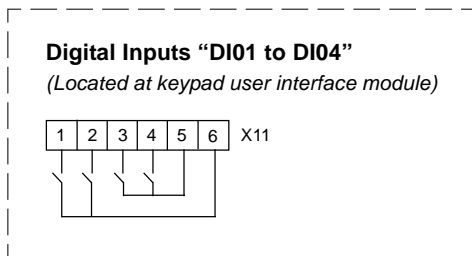

ill. 5

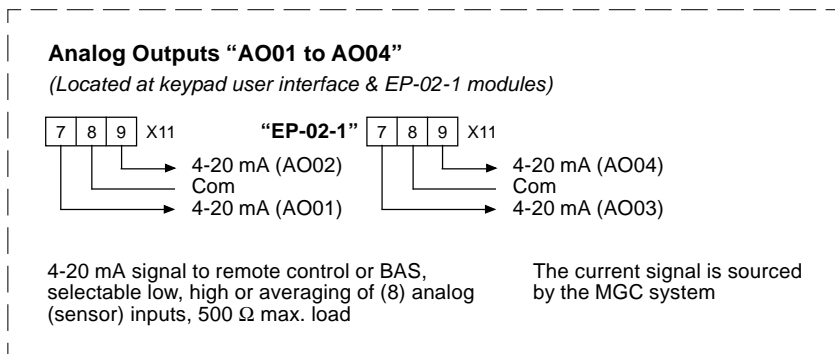

ill. 6