

FEATURES

- ❖ High reliability
- ❖ Universal analog input
- ❖ Valve sequencing option
- ❖ 40, 80 or 120 watt power ratings
- ❖ Panel or remote mounting option
- ❖ Optically isolated phase cut input
- ❖ Lower operating temperature

APPLICATIONS

- ❖ Phase cut amplification
- ❖ Milliamp & DC input to phase cut output
- ❖ Valve sequencing from same signal
- ❖ Isolated milliamp input valve driver

DESCRIPTION

The SMVD is designed to drive large Staefa magnetic valves. It is available as a phase cut amplifier or with a universal analog input. The input section will accept a phase cut, mA, or DC voltage input signal. The mA and DC inputs are non-isolated, however, an isolated mA input is available. The factory output calibration is 6 - 18V phase cut which Staefa recommends for linear valve operation. No other output ranges are available on the SMVD due to it's application specific design. The output of the SMVD is designed to overcome line losses even when mounted in a panel. It is still recommended that the SMVD may be mounted as close to the valve as possible.

OPERATION

The SMVD consists of one of three full wave bridge rectifier for the 40, 80 and 120 Watt versions, 15V DC regulated supply, one opto-isolator and an amplifier section. The isolated input accepts a phase cut input (or milliamps when specified) and two non-isolated inputs accept 0-10V DC and 4-20mA. The phase cut output circuitry is driven by the amplifier section and is scaled specifically for driving magnetic valves. In case of accidental shorting of the output, or in the case that an isolation problem occurs, the SMVD is fused and the output is designed to withstand a direct short. The SMVD has an extremely low output impedance and will operate valves up to one hundred feet away. It is Recommended that the 120W be mounted as close to the valve as possible using a 4" square box, due to the high currents needed to operate the valves.

STAEFA'S RECOMMENDED WIRE LENGTH & SIZE CHART

NORMAL POWER	COPPER WIRE SIZE			
	18GA	16GA	14GA	12GA
40W	40'	60'	75'	100'
80W	20'	30'	40'	60'
120W	12'	20'	30'	50'

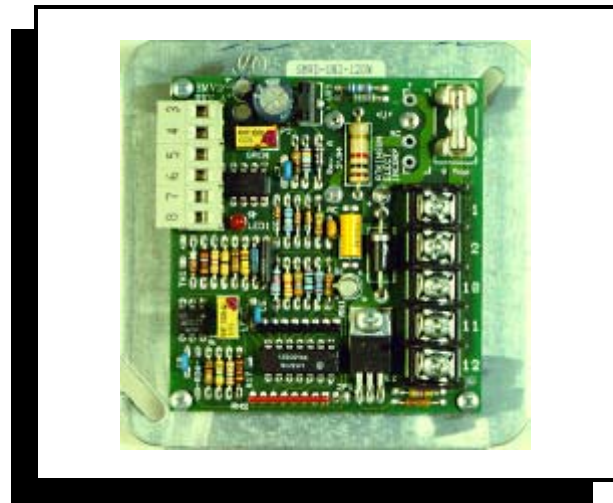

SPECIFICATIONS

- SIZE: 3.25" L x 3" W x 1.5" H
- MOUNTING: 40W - 3.5" x 3" Snap Track
80W - 3.5" x 3" Snap Track
120W - 4" x 4" plate (supplied).
Will fit inside a 4 x 4 box.
- POWER: 24 V AC, ± 10%, 50/60Hz, 2.5VA*
* *Note: When sizing the power transformer, the power rating of the valve must be added.*
- INPUTS : 0-20V phase cut isolated
0-10V DC non-isolated - 10KΩ
4-20mA non-isolated - 250Ω
4-20mA isolated - 600Ω
- OUTPUT: 6-18V phase cut @ 40, 80, or 120W
- ACTION: Direct with 2Hz Filtering
- AMBIENT TEMP: 0 to 50°C.

WIRING CONFIGURATION

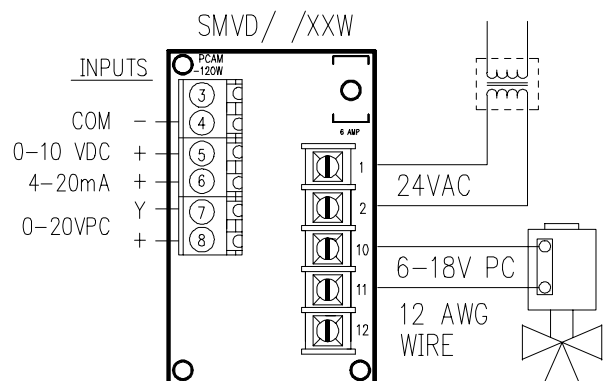

ORDERING INFORMATION

SMVD/XXX/XXX/XX

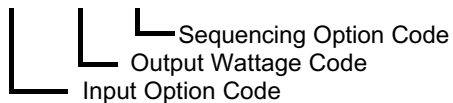

INPUT CODE OPTIONS

- UNI - 4-20mA, 0-10V DC(non-isolated) and 0-20V phase cut isolated (isolated).
- AMP - 0-20V Phase cut (isolated).
- SEQ - 4-20mA, 0-10V DC (non-isolated) and 0-20V phase cut isolated with the same slope sequencing option.
- MAI - 4-20mA (Isolated & non-isolated), & 0-10V DC (non-isolated).
- MIS - 4-20mA (Isolated & non-isolated), & 0-10V DC (non-isolated), same slope sequencing.

OUTPUT WATTAGE CODE OPTIONS

- 40W - 6-18V Phase cut low power, (40 watt).
- 80W - 6-18V Phase cut medium power, (80 watt).
- 120W - 6-18V Phase cut high power, (120 watt).

SEQUENCING OPTION

- 1/2 - 50% - 50% valve operation
- 1/3,2/3 - 33% - 67% valve operation
- 1/3,1/3,1/3 - 33% - 67% -100% valve operation

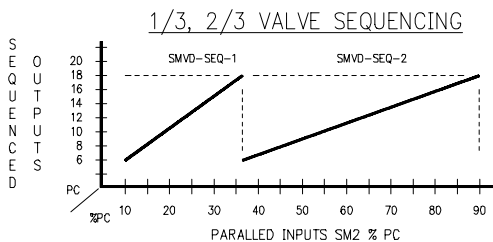
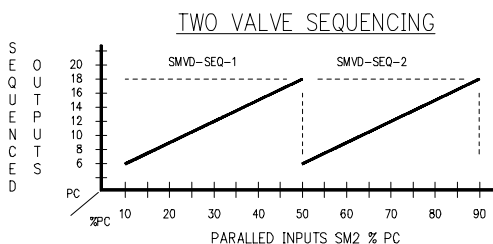

ORDERING CODE EXAMPLES

- SMVD /UNI/120W 0-20V phase cut, 4-20mA, or 0-10V DC to 6-18V phase cut 120 watts.
- SMVD /AMP/40W 0-20V phase cut amplifier only 40 watts, mounted in 3.5" Snap Track.
- SMVD /SEQ/40W 0-20V phase cut, 4-20mA, or 0-10V DC to 6-18V phase cut with sequencing option 40 watts.
- SMVD /MIS/120W Isolated 4-20mA to 6-18V phase cut with sequencing option 120 watts.

PHYSICAL CONFIGURATION 120 WATT

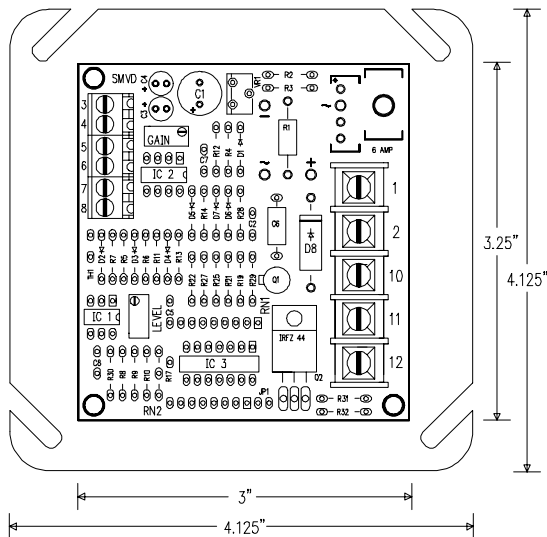

PHYSICAL CONFIGURATION 40 WATT

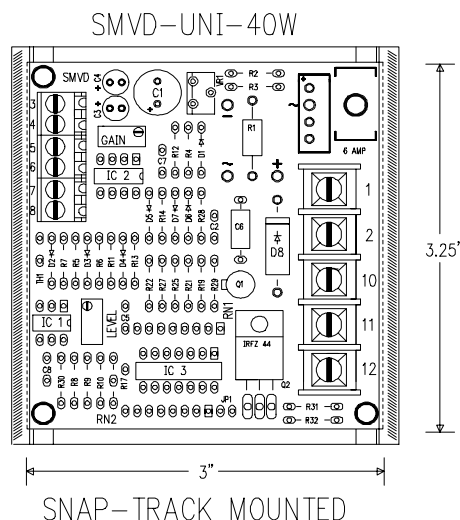

STD MOUNTING - 40, 80, & 120W VERSIONS

- 40W,80W - 3.5" X 3" Snap Track standard
- 4" X 4" Cover plate optional
- 120W - 4" X 4" cover plate only

APPLICATION 1 - PHASE CUT AMPLIFIER

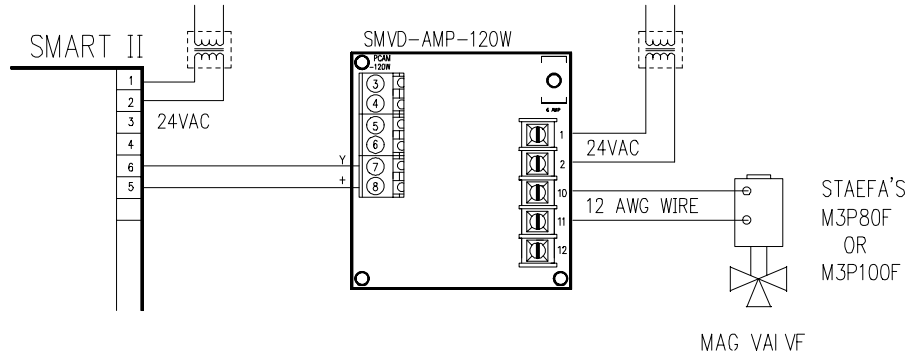

The SMVD-AMP is used for amplifying STA-EFA's phase cut signal to drive the larger magnetic valves (40, 80, & 120 watt magnetic valves).

APPLICATION 2 - UNIVERSAL INPUT TO PHASE CUT OUTPUT CONVERSION

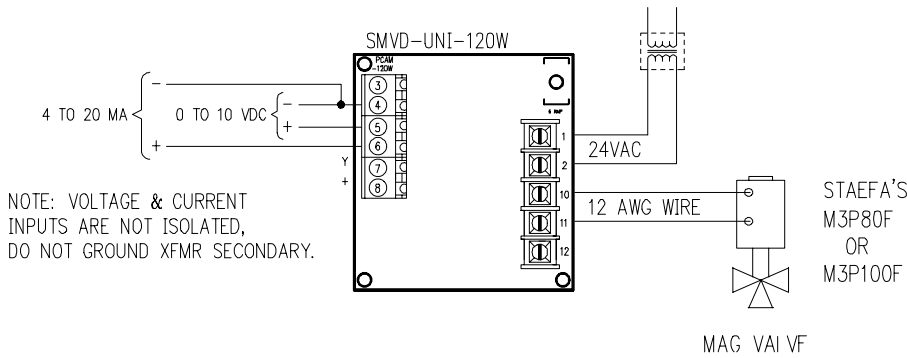

The SMVD-UNI is used for converting 4-20mA, or 0-10V DC or amplifying the 27 watt phase cut signal to 40, 80, or 120 watts to drive the larger Staefa magnetic valves. The SMVD-UNI-5V is used for converting 4-20mA or 0-5V DC to a phase cut signal JP2 is jumpered for 5 V DC operation other wise not jumpered for 4-20mA or 10-90% phase cut operation.

APPLICATION 3 - PHASE CUT WITH EXTERNAL MINIMUM POSITION POTENTIOMETER

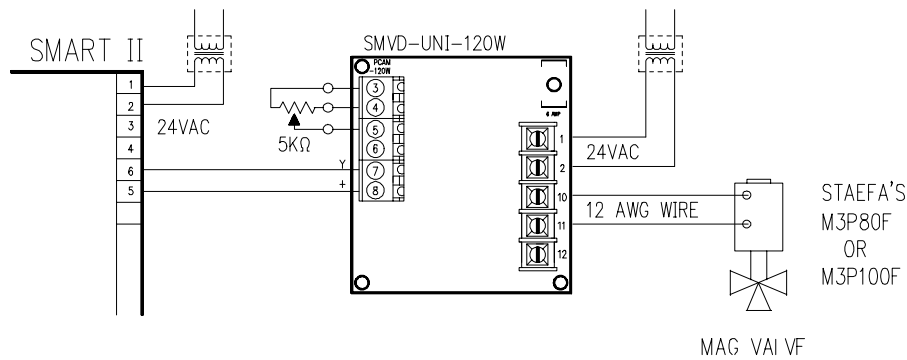

The SMVD-UNI can be used to provide a minimum position or flow. This is done by connecting a 5k ohm potentiometer from terminals 3 to 4 and the wiper to terminal 5. The SMVD-UNI selects the highest of the two input signals and converts to, or amplifies the phase cut signal.

Call for other calibration ranges and versions.

APPLICATION 4 - PHASE CUT INPUT SEQUENCING TWO VALVES

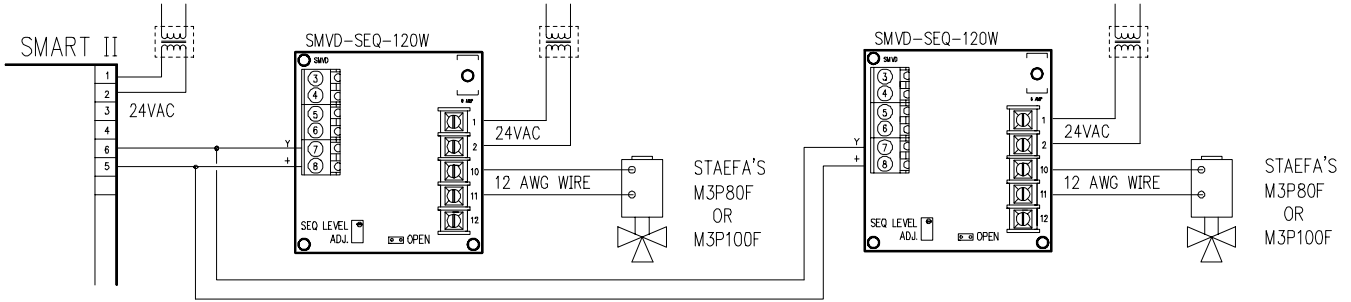

The SMVD-SEQ can be used for 1/3 or 1/2 valve operation by removing the shorting jumper JP1, this doubles the amplifier gain. Manually set your input signal to 33% (1/3 operation), or 50% (1/2 operation) for the 1st valve. Then adjust the 20k ohm sequencing level pot for the desired operating range. For 2/3 valve operation JP1 should be installed. Manually set your input to 100% for the 2nd valve. Then adjust the 20k ohm sequencing level pot on the 2nd SMVD for the desired operating range.

APPLICATION 5 - PHASE CUT INPUT SEQUENCING THREE VALVES

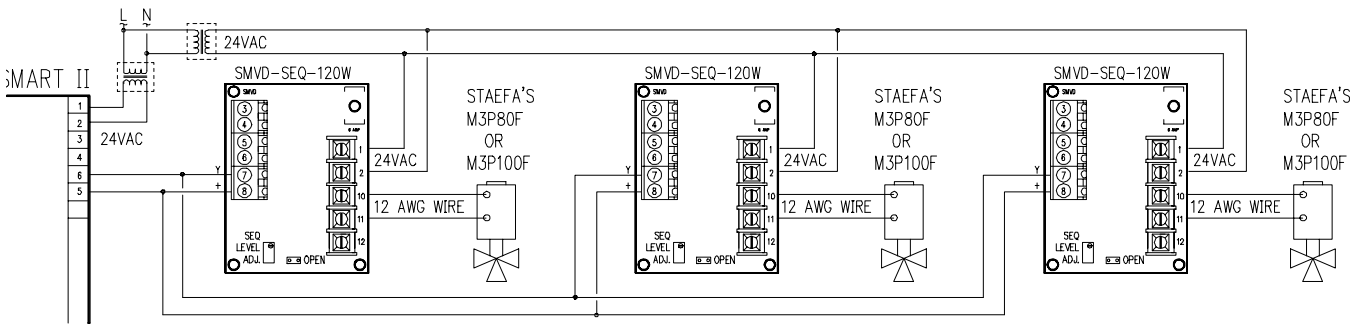

For three phase cut valves, each operating over 1/3 of the input signal, remove shorting jumper JP1, this doubles the amplifier gain. Manually set your input to 33% (1/3 operation), for the 1st valve. Then adjust the 20k ohm sequencing level pot on the first SMVD for the desired operating range. For the second valve, manually set your input to 66% and then adjust the 20k ohm sequencing level pot on the 2nd SMVD for the desired operating range. For the third valve, manually set your input to 100% and then adjust the 20k ohm sequencing level pot on the 3rd SMVD for the desired operating range.

APPLICATION 6 - ISOLATED 4 to 20mA INPUT TO PHASE CUT OUTPUT CONVERSION

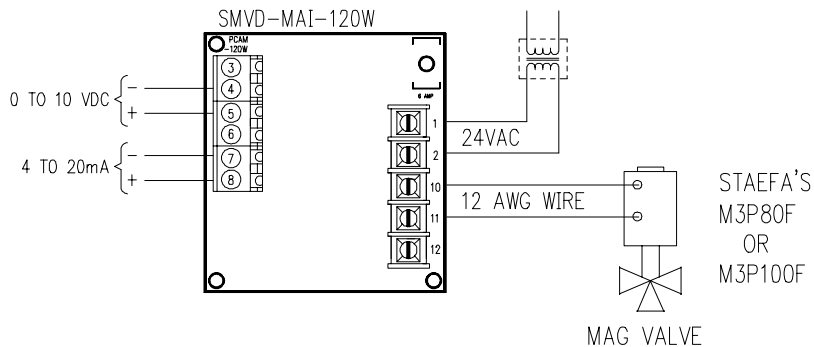

The SMVD-MAI is used for converting 4-20mA, or 0-10V DC signal to 40, 80, or 120 watts to drive the larger Staefa magnetic valves. The SMVD-MAI-5V is used for converting 4-20mA or 0-5V DC to a phase cut signal JP2 is jumpered for 5 V DC operation other wise not jumpered for 4-20mA or 10-90% phase cut operation.

APPLICATION 7 - ISOLATED 4 TO 20mA WITH EXTERNAL MINIMUM POSITION POTENTIOMETER

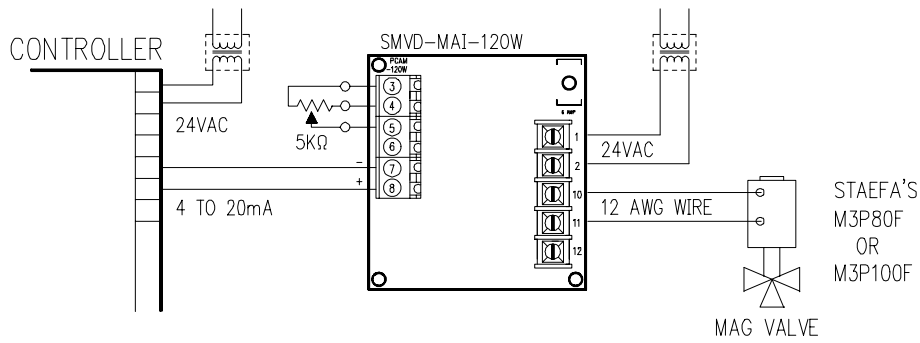

The SMVD-MAI can be used to provide a minimum position or flow. This is done by connecting a 5k ohm potentiometer from terminals 3 to 4 and the wiper to terminal 5. The SMVD-MAI selects the highest of the two input signals and converts to the phase cut signal.

APPLICATION 8 - 4 TO 20mA INPUT SEQUENCING TWO VALVES

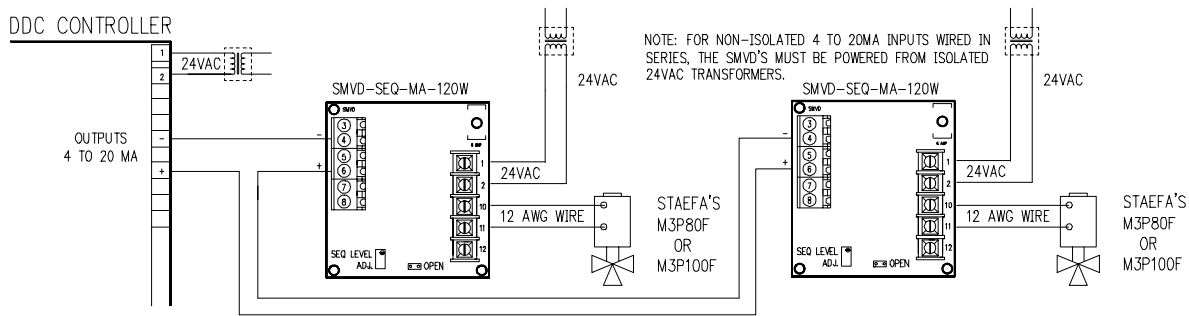

The SMVD-SEQ can be used for sequencing two valves using a 4-20mA input signal. For 1/2 valve operation remove shorting jumper JP1, this doubles the amplifier gain. Manually set your input signal to 50% (1/2 operation) for the 1st valve. Then adjust the 20k ohm sequencing level pot for 18V phase cut output. Manually set your input signal to 100% for the 2nd valve. Then adjust the 20k ohm sequencing level pot on the 2nd SMVD for 18V phase cut output.

APPLICATION 9 - ISOLATED 4 TO 20mA INPUT SEQUENCING TWO VALVES

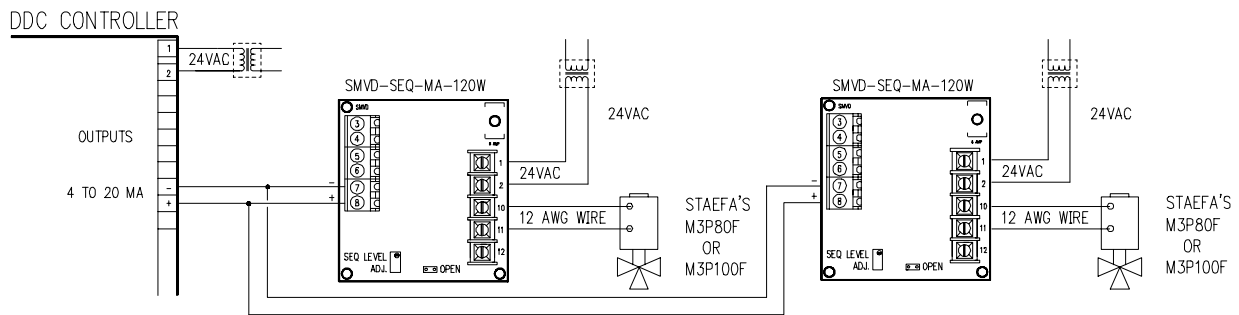

The SMVD-MIS is used for sequencing two valves using isolated 4-20mA inputs. The 4-20mA signal MUST be able to source 1000 ohms of input resistance. Follow setup instructions on application #5.

Call for other calibration ranges and versions.

APPLICATION 10 - 4 TO 20mA INPUT SEQUENCING THREE VALVES

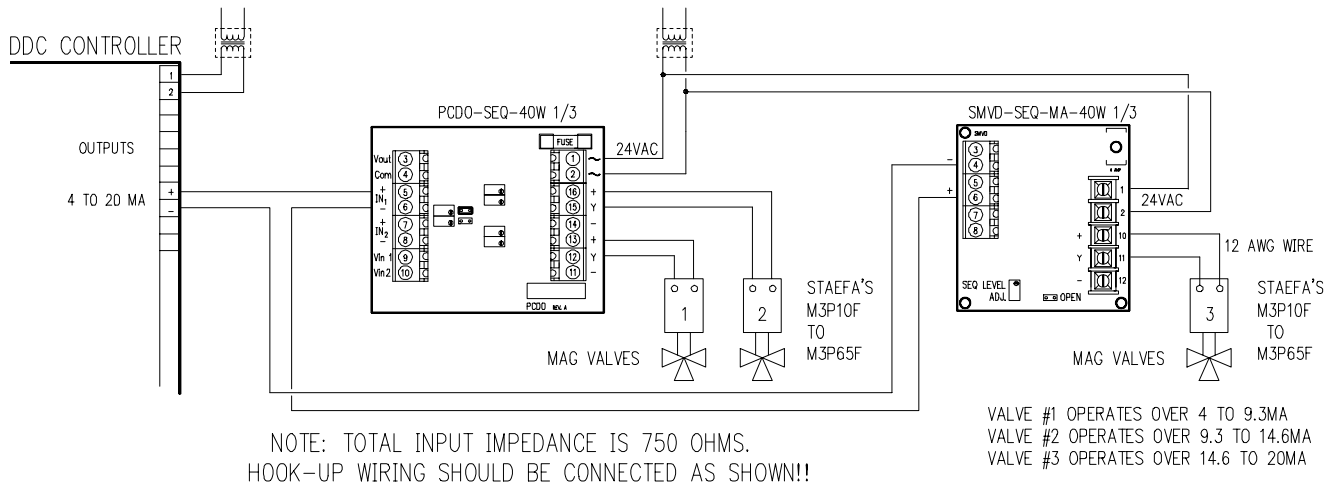

In this application we use a PCDO and a SMVD in series to sequence three 40W valves, using a signal 4 to 20mA input signal. This keeps the overall input impedance down around 750 ohms, otherwise with three optically isolated SMVD's would result in around 1500 ohms of input impedance. The PCDO can be setup to use only one input to drive the two outputs. The DDC Controller's 4 to 20mA signal is fed into the PCDO's terminal #5 and out on terminal #6, then into the SMVD's terminal #5 and out on terminal #4, and back to the controller. The PCDO and SMVD are factory setup for 1/3, 1/3, 1/3 operation, refer to the PCDO sheets for field calibration and follow application 7 for field adjustments on the SMVD.

Call for other calibration ranges and versions.