

# Combustible Gas Detection and Control System



**PolyGard  
SPC-3300**

## DESCRIPTION

Stand-alone, wall-mounted, single-point analog electronic control system for combustible gas detection, control and alarm.

## APPLICATION

To detect and control levels of combustible gases and vapors in commercial applications such as boiler rooms (i.e. Methane), dry cell battery rooms (i.e. Hydrogen), gas/fuel spill locations (i.e. Gasoline, Hexane), laboratories and industries (i.e. Butane, Propane), etc. The controller can interface via binary outputs and a 1-5 VDC signal with any compatible analog electronic control, DDC/PLC control or automation system.

## FEATURES

- Continuous monitoring
- Four (4) relay outputs:
  - Two-stage control
  - One (1) remote alarm
  - One (1) remote fail-safe
- Low alarm, manual override
- One (1) 1-5 VDC output
- Catalytic bead (pellistor) sensor, long-life
- RFI/EMI protected
- Easy plug-in sensor
- Built-in horn
- Optional package:
  - Digital display
  - LED status indicators
  - Test/Reset push buttons
- Power supply fused
- Lockable enclosure
- NEMA 4 w/splash guard
- Easy maintenance



City of Los Angeles Approved

## SPECIFICATIONS

### Electrical

Power supply 120 VAC, -10%/+20%, 50/60 Hz or 24 VAC/VDC, 1.6 A fused

Power consumption 0.6 A (15 VA), max.  
- w/optional heater 1.6 A (39 VA), max.

### Sensor Performance

Gas detected Combustible gases and vapors (refer to table)

Sensor element Catalytic bead (pellistor), diffusion

Range 0-100% LEL

Detection limit 0.5% LEL

Accuracy ± 1% of reading

Repeatability ± 2% of reading

Long term zero point drift < 5% LEL<sub>methane</sub>/year

Long term sensitivity drift < 2% LEL<sub>methane</sub>/month

Response time t<sub>90</sub> < 10 sec.<sub>methane</sub>

Sensor life expectancy 3 yrs., normal operating environ.

Sensor coverage Dependent upon target gas

### Installation Location

Mounting height Dependent upon target gas

### Relay outputs

Low alarm 1K1 (R1) DPDT, 10 A (optional time delay relay, 10 A)

High alarm 1K2 (R2) DPDT, 10 A

Remote alarm (R3) SPST, 5 A

Fail-safe (R4) SPST, 5 A potential free, 250 VAC max. "R3 and R4" interlocked with low or high alarm, selectable

Manual override Low alarm override switch

### Type of Control

General Two-stage, low and high alarm

Trip/setpoints

- low alarm 20% LEL
- high alarm 40% LEL

Switching differential 4% or 10% of measuring range, selectable

Analog output signal (1) 1-5 VDC, isolated > 50 kΩ

Audible alarm 90 dB, enabled or disabled, slct.; assignable to low alarm (relay R1) or to high alarm (relay R2)

Combustible Gases/Vapors	% v/v*
Acetone (CH <sub>3</sub> ) <sub>2</sub> CO	2.6
Acetylene C <sub>2</sub> H <sub>2</sub>	2.4
Cyclohexane C <sub>6</sub> H <sub>12</sub>	1.3
Ethylene CH <sub>2</sub>	2.3
Ethane C <sub>2</sub> H <sub>6</sub>	3.3
Ethyl Acetate CH <sub>3</sub> COOC <sub>2</sub> H <sub>5</sub>	2.2
Ethyl Alcohol C <sub>2</sub> H <sub>5</sub> OH	3.3
Gasoline C <sub>6</sub> H <sub>6</sub>	1.4
Heptan C <sub>7</sub> H <sub>16</sub>	1.1
Hydrogen H <sub>2</sub>	4.0
Isopropyl Alcohol (CH <sub>3</sub> ) <sub>2</sub> CHOH	2.2
JP8 -	0.9
Methane CH <sub>4</sub>	5.0
Methanol CH <sub>3</sub> OH	6.7
n-Butane C <sub>4</sub> H <sub>10</sub>	1.8
n-Hexane C <sub>6</sub> H <sub>14</sub>	1.2
n-Octane C <sub>8</sub> H <sub>18</sub>	0.95
n-Pentane C <sub>5</sub> H <sub>12</sub>	1.4
Propane C <sub>3</sub> H <sub>8</sub>	2.1

\* x% v/v = 100% LEL  
LEL = Lower Explosive Limit  
v/v = Volume by Volume

**SPECIFICATIONS**

**Type of Control (cont...)**

- unit w/o display      Horn reset push button, built-in

**Optional Display,**

**LED Indicators and Test/Reset Push Buttons**

Digital display      3.5 digits, %LEL reading

LED status indicators

- power/operating LED      Green = power on  
    Red = failure  
    Orange = low alarm  
    Red = high alarm  
 Test, alarm acknowledgment, and reset push buttons      Low alarm, auto reset;  
    High alarm, auto reset  
    or manual reset (w/optional display), selectable

Reset buttons

- high alarm (2. alarm)      LED on = is on w/high alarm (only w/latched relay)  
 - audible      LED on = is on w/internal horn and/or relay R3 for remote alarm display

**Environmental**

Permissible ambient

- working temperature      23°F to 104°F (-5°C to 40°C)  
 - storage temperature      41°F to 104°F (5°C to 40°C)  
 - humidity, continuous      15 to 90% RH, non-condensing  
 - humidity, intermittent      1 to 99% RH, non-condensing  
 - working pressure      Atmospheric ± 10%

**Optional**

**Heater, built-in**

Ambient temperature      -22°F to 104°F (-30°C to 40°C)  
 Thermostatic control      32°F (0°C) ± 5°F (3°C)

**Physical**

Enclosure

- material      Steel case  
 - color      Light beige  
 - protection      NEMA 4 (IP 55)  
 - installation      Wall (surface) mounted

Dimensions (H x W x D)

- base      9.06 x 8.27 x 5.60 in.  
    (230 x 210 x 142 mm)  
 - splash guard (H x Ø)      0.63 x 2.56 in. (16 x 65 mm)  
 Cable entry      3 holes for 1/2 in. conduit, covered

Wire connection

Terminal blocks, screw type for lead wire  
 Wire size      Min. 24 AWG (0.25 mm<sup>2</sup>),  
    Max. 14 AWG (2.50 mm<sup>2</sup>)  
 Weight      8.8 lbs. (4.0 kg)

**Approvals/Listings**

- unit      City of Los Angeles Approved  
    CE  
    EMV-Compliance 89/336/EWG  
 - sensor/transmitter      City of Los Angeles Approved  
 - relays (R1, R2)      UL Recognized, CSA Certified, TÜV  
 - transformer      UL Listed, CSA Certified  
**Warranty**      Two years material and workmanship

**ORDERING INFORMATION**

**SPC-3300 - 0 00 0 US**

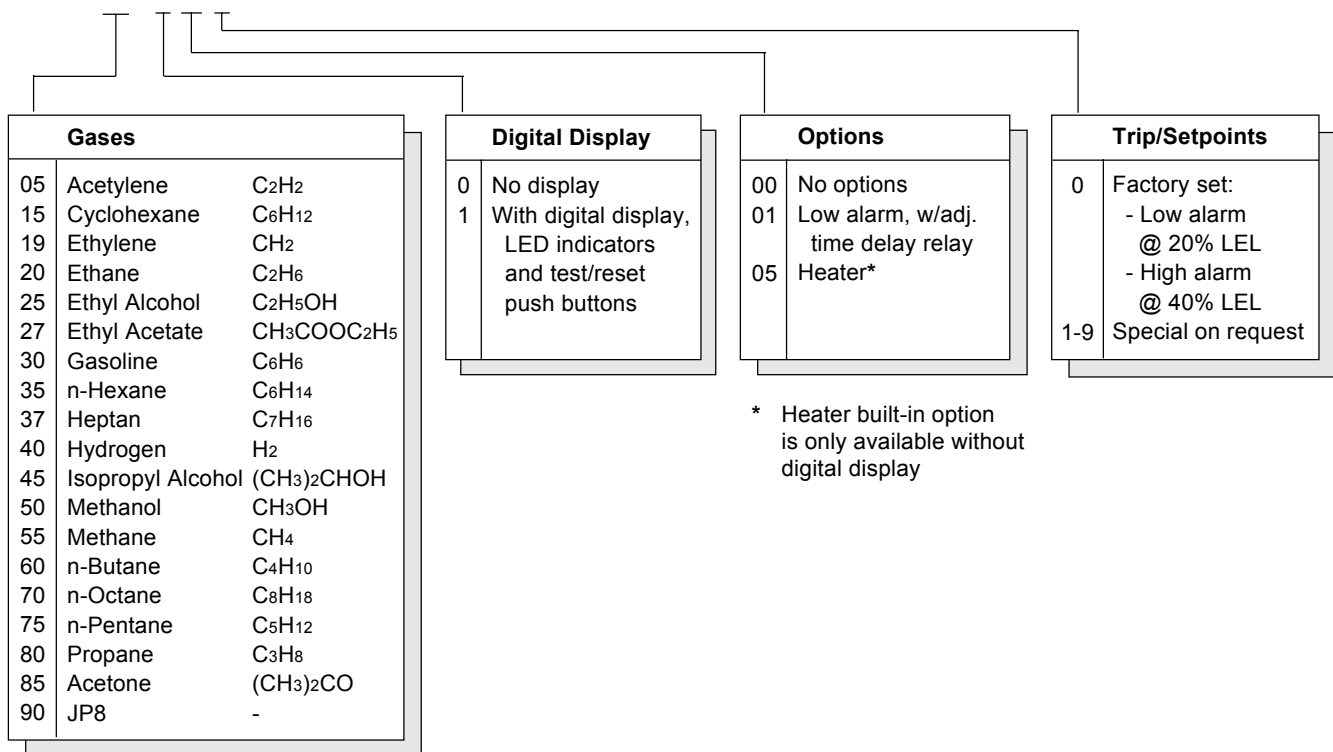

**FIELD WIRING CONFIGURATION**

Low alarm level option, with time delay relay (instead of standard relay)

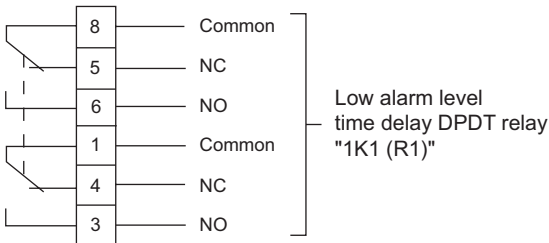

NC	NO	Low Alarm Time Delay Relay 1K1 (R1)	coil	C	RTE-P11
NC	NO		coil	C	

Note: NC-NO connection is reversed on the relay socket compared to the standard relay

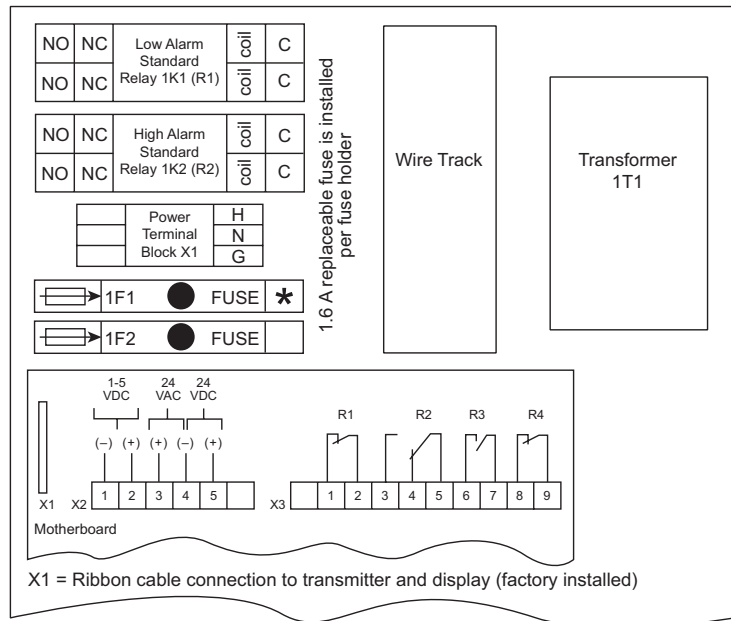
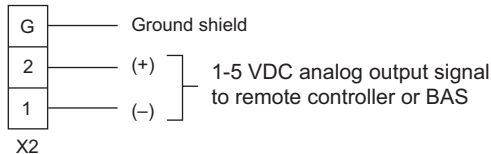
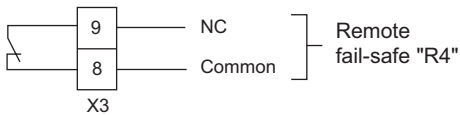
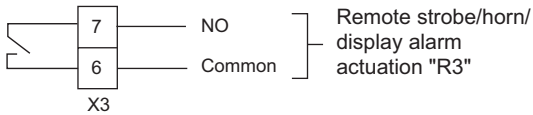
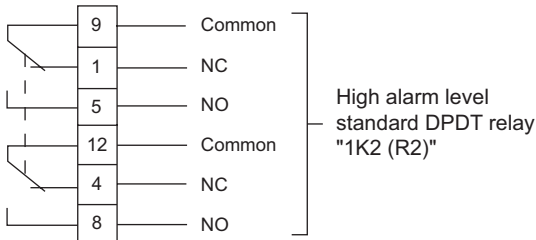
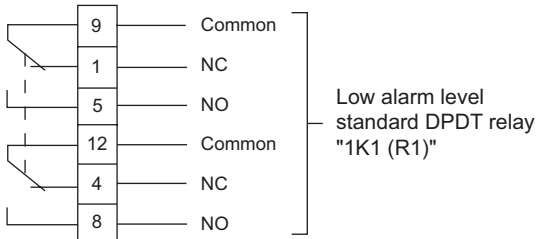

Power terminal block "X1"

Gray	H	AC hot	120 VAC or 24 VAC/DC power supply
Blue	N	AC neutral	
Green/yellow	G	Earth ground	

\* With 24 VAC/DC power supply:

- Remove factory installed transformer "1T1" and transformer wires
- Disconnect lead wire from "1F2" fuse block terminal and connect to "1F1 \*(right hand)" fuse block terminal



- Add wire and connect between AC neutral "N (leftside)" of power terminal block and "X2 - terminal 4" of motherboard

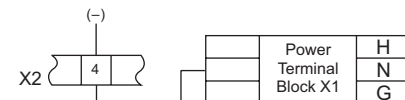

- Relay contact positions 1K1 (R1), 1K2 (R2), R3 and R4:
- Power off, as drawn
  - Power on and no alarm condition, as drawn, and R4 is open
  - Power on and alarm condition for 1K1 (R1), 1K2 (R2) and R3, contacts are closed between common and NO, and R4 stays open
  - Power loss or system failure, R4 is closed

**Recommended**

- Twisted, shielded wire for 1-5 VDC output signal
- Grounded housing