

Carbon Monoxide (CO) Gas Detection and Control System



**PolyGard
SPC2-1112**

DESCRIPTION

Gas monitor with built-in carbon monoxide (CO) sensor, wall-mounted, accepts inputs from remote devices such as other gas sensors, temperature or humidity sensors.

APPLICATION

To detect and control levels of carbon monoxide (CO) and other gases in a wide variety of commercial and industrial applications such as vehicle exhaust in parking structures, engine repair shops, equipment rooms and ventilation systems, etc. The controller can interface via binary outputs and up to (2) 4-20 mA signals with any compatible electronic analog control, DDC/PLC control or automation system.



FEATURES

- *Continuous monitoring*
- *One (1) built-in CO electrochemical sensor, gas specific*
- *Easy plug-in sensor*
- *Three (3) remote analog inputs, 4-20 mA*
- *Five (5) relay outputs:*
 - *Five-stage control*
 - *Fail-safe assignable*
- *Two (2) analog outputs, 4-20 mA*
 - *Selectable for low, high or averaging*
- *Liquid Crystal Display (LCD)*
- *LED status indicators*
- *Accepts combination of toxic or combustible gases, refrigerants, temperature or humidity remote sensor inputs*
- *Built-in horn*
- *Keypad user interface*
- *Simple menu-driven programming*
- *RFI/EMI protected*
- *Modular technology*
- *Overload & short-circuit protected*
- *NEMA 4X enclosure*
- *Easy maintenance*



City of Los Angeles Approved



NRTL Performance Tested & Certified
Conforms to STD
UL 2075 / UL 2017

SPECIFICATIONS

Electric

Power supply	24 VAC/VDC, -15%/+20%, 50/60 Hz, auto-resettable fuse
Power consumption	13 VA (0.5 A), w/max sensor connections
RF/EMI protected	4.0 W @ 3 ft. (1 m) radiated

Sensor Performance

Gas detected	Carbon monoxide (CO)
Sensor element	Electrochemical, diffusion
Range	Span field adjustable from 0-200 to 0-300 ppm via calibration, 0-250 ppm factory set
Resolution	± 3.0 ppm of reading
Repeatability	± 3.0% of reading
Long term output drift	< 0.42% signal loss/month
Response time	t ₉₀ < 50 sec.
Sensor life expectancy	3-5 years, normal operating environment
Sensor coverage	5,000 sq.ft., max. 10,000 sq.ft. (465 m ² , max. 930 m ²), under "ideal conditions"

Installation Location

Mounting height	5 to 6 ft. (1.5 to 1.8 m) above floor
-----------------	---------------------------------------

Type of Control

General	Five-stage (S1 to S5) control, assignable up to five (5) binary/relay output, i.e. Low-med-high-fault/fail-horn*, or low1-low2-med1-med2-high, or any other combinations (* = horn/audible alarm built-in and factory pre-configured to relay output "R05")
Analog inputs	Three (3) 4-20 mA, for additional remote sensors
Analog reading	Current and mean (average) value
Stage level / setpoint	Field adjustable over full range, five (5) per analog input, assignable to current or mean (average) value
- hysteresis/ switching differential	Selectable for each sensor point
Digital inputs	Four (4), each can be individually assigned to any relay (R1...R5). Digital inputs are used for remote audio/visual alarm reset

SPECIFICATION

Type of Control (Cont...)

Relay outputs (R1-R5) w/ status LEDs	Five (5) SPDT, 8A 24 VAC/VDC-250 VAC contact resistance 100 mΩ, max.
- each stage level (S1-S5)	Assignable to any relay
- sensor fail-safe	Assignable to any stage level
Time delay switching	Selectable for make and brake of each sensor point (SP1 to SP4) 0-9,999 seconds
Analog output	Two (2) independent 4-20 mA signal, 500 Ω max. load, selectable as low, high or averaging of sensor inputs
Audible alarm	85 db (10 ft), enabled or disabled, selectable; assignable to stage level S1, S2, S3, S4 or S5
Alarm acknowledgement	Menu-driven and system reset function for latched relays

User Interface

Keypad type	Refer to "illustration keypad user interface"
Touch buttons	Six (6)
Status LED's	Red: Alarm Yellow: Fault (fail)
Digital display	Liquid Crystal Display (LCD), two lines, 16 characters per line, 1 digit resolution, backlit
- unit display	Menu selectable, per sensor; ppm, %v/v, %LEL, °F or % RH

Environmental

Permissible ambient	
- working temperature	23°F to 104°F (-5°C to 40°C)
- storage temperature	23°F to 86°F (-5°C to 30°C)
- humidity	15 to 95% RH, non-condensing
- working pressure	Atmospheric ± 10%

Physical

Enclosure (panel)	
- material	Polycarbonate, impact resistance EN 50102/IK08, flammability rating UL 94-5V
- conformity	UL Type 1, UL 508/UL 50 standards
- color	Light gray, smoked gray for cover
- protection	NEMA 4X (IP 65)
- installation	Wall (surface) mounted
Dimensions (H x W x D)	
- base	7.9 x 7.5 x 4.1 in. (200 x 190 x 105 mm)
Cable entry	5 holes for 1/2 in. conduit, covered
Wire connection	Terminal blocks, Push-on connect and screw type for lead wire
Wire size	
- input	Min. 22 AWG (0.34 mm ²) Max. 16 AWG (1.50 mm ²)
- output	Min. 24 AWG (0.25 mm ²) Max. 14 AWG (2.50 mm ²)
Weight	4.5 lbs. (2.0 kg)

**Approvals / Listings
System**

	NRTL Performance Tested & Certified:
- sensor/transmitter	Conforms to STD ANSI/UL 2075
- controller	Conforms to STD ANSI/UL 2017
- transmitter & controller	City of Los Angeles CE
	VDI 2053, air treatment systems for garages and tunnels
	EMV-Compliance 89/336/EWG
- enclosure (panel)	UL Listed, E75645

Warranty

One year material and
workmanship

ORDERING INFORMATION

SPC2-1112 - 0 00 US

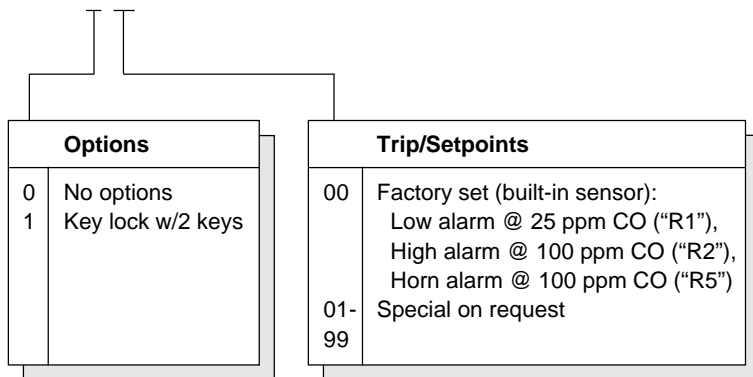

Standard control system, ordering part
number:

SPC2 - 1112 - 000 US,
configuration includes:

Digital, programmable controller with
menu-driven keypad user interface,
LCD & LEDs, 24 VAC/VDC, 50/60 Hz
NEMA 4X enclosure

- Built-in: (1) CO sensor/transmitter
(1) Horn, audible alarm
- Inputs: (3) 4-20 mA, for remote sensors
(4) Digital
- Outputs: (5) Relays, SPDT, 8 A
(2) 4-20 mA

USER INTERFACE & CONTROLLER

Keypad User Interface

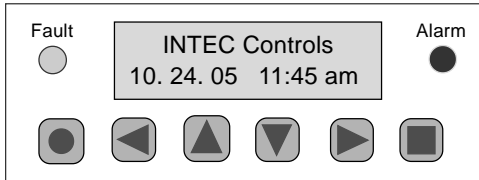

- Fault
"Yellow LED" Flashes at system / sensor failed
- Alarm
"Red LED" Flashes when any stage level setpoint is exceeded; steady when any relay output is in manual override operation
- Scroll down & up in Main menu and Sub menus; increases or decreases a value
- Navigates through menus on the same level; moves cursor when inputting data
- Exits programming and saves settings or return to previous level or menu
- Enter Sub menus or stores data; horn silence (if assigned)

Main Page & Main Menu

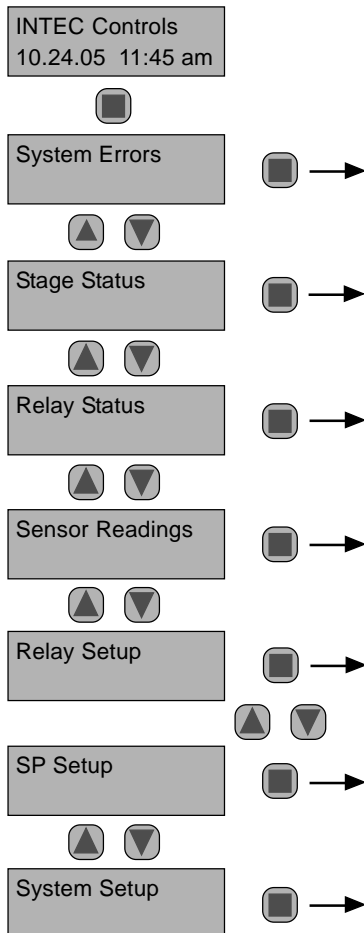

System Operation

All Programming is made via the keypad user interface in combination with the display screen. Security is provided via two password levels. The lower level password allows to override or to reset system status functions. The upper level password allows all programming and override functions.

Main Page Display

Displays date and time, unless a system error occurs, then the error is displayed.

Main Menu

Displays headings of "System Errors", "Stage Status", "Relay Status", "Sensor Readings", "Relay Setup", "SP (Sensor Point) Setup", and "System Setup".

Sub Menu "System Errors"

Displays errors, reset corrected errors, and historical error summary.

Sub Menu "Stage Status"

Displays status of each "SP" sensor point, stage level/ setpoint exceeded.

Sub Menu "Relay Status"

Displays status and manual control of each output relay.

Sub Menu "Sensor Readings"

The current and mean/average values are displayed for each "SP" sensor point with sensing type and engineering unit (ppm, %v/v, %LEL, F, %RH).

Sub Menu "Relay Setup"

Enter and /or change parameters of each relay.

- Assign de-energized or energized normal operation
- Select steady or flashing function
- Select horn function
- Select latching or non-latching mode
- Select digital input usage, and assign to any output relay

Sub Menu "SP Setup"

Enter and/or change parameters of each sensor point.

- Activate sensor point
- Select sensor point type (gas, temperature, humidity)
- Select measuring range
- Select sensor signal
- Select stage/setpoint 1 to 5
- Select hysteresis
- Set delay ON/OFF time
- Select current or mean/average value
- Assign sensor point fault to stage level setpoint
- Assign setpoint 1 to 5 to any output relay
- Assign to analog Output

Sub Menu "System Setup"

Enter and/or change system parameters.

- Select service mode
- Set next maintenance date
- Select service phone number
- Select averaging function, time and overlay, of any SP
- Set date, time and time format
- Change customer password
- Select analog output function
- Set failure relay
- Select power ON time
- Select appropriate hardware configuration

FIELD WIRING CONFIGURATION

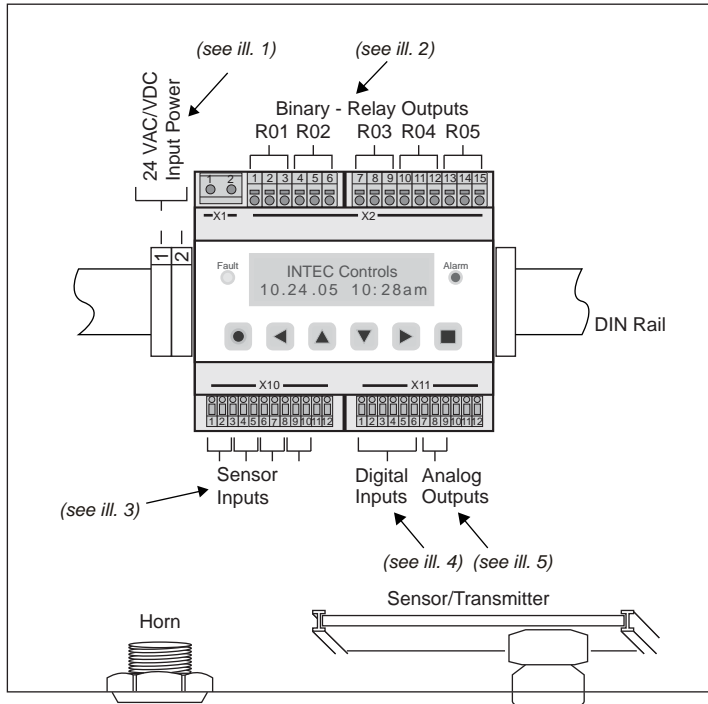

Recommended

- **Twisted, shielded wire for analog inputs**
(Shield to be terminated and connected only at the sensor/transmitter location)
- **Grounded housing**

Caution:

The non-metallic enclosure does not provide grounding between conduit connections. Use grounding bushings and jumper wires.

The enclosure is to be mounted using the mounting holes located in the base external to the equipment cavity, or the equivalent.

The conduit hubs must be connected to the conduit before connected to the enclosure.

When connecting conduit to the enclosure use only UL listed or UL recognized conduit hubs that have the same environmental type rating as the SPC2 enclosure.

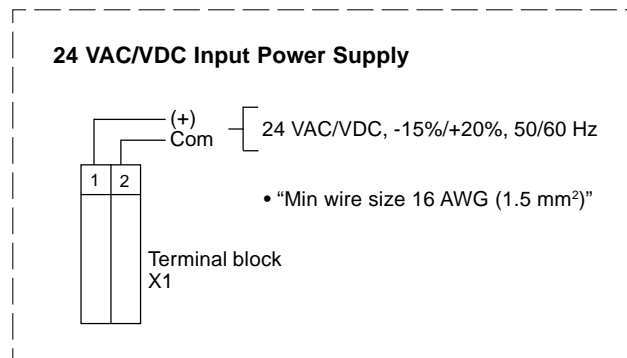

ill. 1

FIELD WIRING CONFIGURATION (cont...)

