

Description

The SSS-1000 sensors are designed to sense differential pressure in the inlet section of variable air volume terminal units and fan terminal units. They can also be used to sense differential pressure at other locations in the main, or branch, duct systems.

The "H" port senses total pressure and the "L" port senses static pressure. The difference between these signals is the differential, or velocity pressure.

Models offer up to four sensing points and lengths of 3-5/32" to 9-29/32" to accommodate box size diameters of 4" to 16".

Applications

The SSS-1000 Series sensors are typically used in conjunction with the CSC-1000, 2000, and 3000 series of VAV terminal controllers for individual zone control in HVAC systems.



Models

SSS-1002	One sensing point; 3-5/32" (80 mm) length
SSS-1003	Two sensing points; 5-13/32" (137 mm) length
SSS-1004	Three sensing points; 7-21/32" (195 mm) length
SSS-1005	Four sensing points; 9-29/32" (252 mm) length

Details

All dimensions in inches (mm).

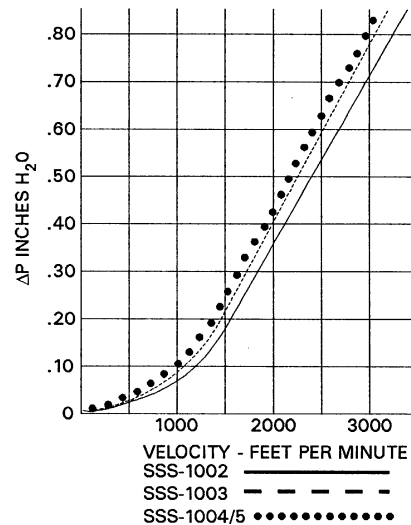
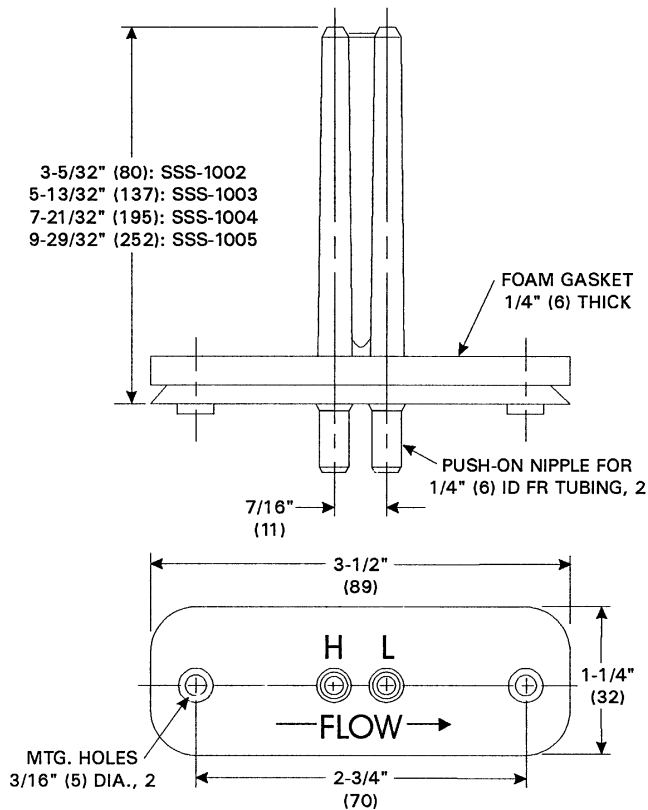

Specifications

Material	Light almond ABS/ Polycarbonate (UL94-5V)
Mounting	Integral flange with gasket
Connection	1/4" (6 mm) nipple for 3/8" (10 mm) O.D. polyethylene tubing
Weight	1 oz. (28 grams)
Temperature Limits	
Operating	40° to 120° F (4° to 49° C)
Shipping	-40° to 140° F (-40° to 60° C)

INTEC
 CONTROLS

9730 Distribution Ave.
 San Diego, CA 92121

Ph: 858-578-7887
 Fx: 858-578-4633

Email: info@inteccontrols.com
www.inteccontrols.com