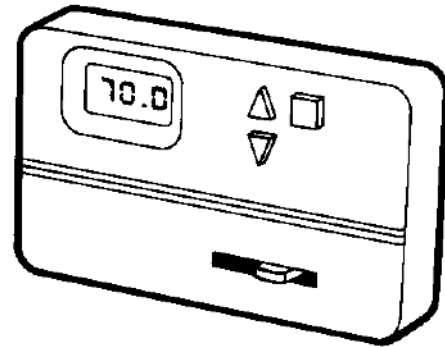

**Digital, Proportional Thermostat/Controller  
General Instructions****Application**

The T168 series microprocessor based thermostat/controller provides a 0-10 Vdc or 4-20 mA control. This series controls a variety of two-pipe and four-pipe fan coil units, air handling units, unitary equipment, and various heating and cooling applications.

The microprocessor combines a proportional plus integral control algorithm with advanced adaptive logic. This provides control without the need for tuning or calibrating the control algorithm in the field.

**T168 Series****Features**

- Digital display of set point, ambient temperature, and operating mode
- 0-10 Vdc or 4-20 mA heat and cool outputs
- Remote setback capability from a time clock or facility management system (contact closure)
- Auxiliary heat function
- Remote and seasonal changeover sensor
- Fahrenheit or Celsius display capability
- In two pipe mode a built-in purge cycle assists the controller to determine if the controlling agent is providing heating or cooling
- Line voltage continuous on/off or 3-speed fan control
- Low voltage fan cycling operation with demand output

# SPECIFICATIONS

## Inputs

**Power Input:** 20 to 28 Vac, nominal 24 Vac.

**Power Consumption:** 25 mA maximum at 24 Vac.

**Connections:**

**Power,** Terminal strip with screw down terminals.

**Control,** Terminal strip with screw down terminals.

**Control Signal Load (Resistive):** 0-10 Vdc, Minimum 1,000 T. 4-20 mA, 100 - 600 T.

## Outputs

**Electrical:**

**Thermostatic Switch Rating,** 10 VA @ 24 Vac.

**Fan Switch Current Ratings,** Refer to Table-1.

**Proportional Band,** 2F degrees (1.1C degrees).

**Setpoint Adjustment Range,** 50 to 90°F (10 to 32°C).

**Heating/cooling Changeover Deadband,** 3F degrees (1.6C degrees).

**Mechanical:**

**Display Range,** 32 to 99°F (0 to 37°C)

**Set point Range,** 50 to 90°F (10 to 32°C).

**Material,** Rigid vinyl.

**Finish,** Cool gray.

## Environment

**Temperature limits:**

**Shipping & Storage,** -30° to 130°F (-34° to 55°C).

**Operating,** 32° to 130°F (0° to 55°C).

**Humidity:** Non-condensing.

**Shipping Weight:** 0.6 lbs (270 g).

**Location:** NEMA Type 1.

## Agency Listings

**CE:** Compliant.

**Table-1 Fan Switch Current Ratings (Amps).<sup>1</sup>**

Voltage	Inductive		Resistive Amps	Pilot Duty
	FLA	LRA		
24	N/A	N/A	N/A	24 VA
120	5.8	34.8	6.0	125 VA
240	2.9	17.4	5.0	125 VA
277	2.4	14.4	4.2	125 VA

<sup>1</sup> When Fan Switch is off, all thermostat heat/cool and fan functions are off.

**Table-2 Model Chart.**

Model	Outputs	Fan Control	Demand Output	Auxiliary heat	Setback	System Modes
TA168-001	Dual	None*	No	Yes	Yes	Off-Auto-Heat-Cool
TA168-002	Dual	Off-Hi-Med-Lo	Yes	Yes	Yes	Off-Auto-Heat-Cool
TA168-003	Single	Off-Hi-Med-Lo	Yes	No	Yes	Off-Heat/Off-Cool
TA168-004	Single	None*	No	No	Yes	Off-Heat/Off-Cool
TA168-005	Single	None*	Yes	No	Yes	Off-Heat/Off-Cool
TA168-006	Dual	None*	Yes	Yes	Yes	Off-Auto-Heat-Cool
TA168-007	Single	Off/On	Yes	No	Yes	Off-Heat/Off-Cool
TA168-008	Dual	Off/On	Yes	No	Yes	Off-Auto-Heat-Cool

\* Fan terminals do not exist on these models. If equipped with a demand terminal, the demand terminal is powered with 24 V on a call for heat or cooling. The demand terminal output can be used to control a fan relay, 10 VA @ 24 Vac.

### Accessories

- 65345 4-3/4" x 4-3/4" adapter plate.
- 65406 Remote sensor, 60" leads 10k T @ 77°F (25°C).

### TYPICAL APPLICATIONS (wiring diagram)

**▼ CAUTION**

- Keep all wiring at least 1-1/2 ft. (45.7 cm) away from any potential source of electrical interference or noise.
- Do not run sensor wire parallel to line voltage wiring.
- Do not run sensor wire in conduit with line voltage.
- When low voltage or sensor wiring must intersect line voltage, cross at perpendicular angle to minimize electrical noise.

**3 SPEED FAN CONTROL**

24 - 277 VAC  
VOLTAGE  
CONNECTION

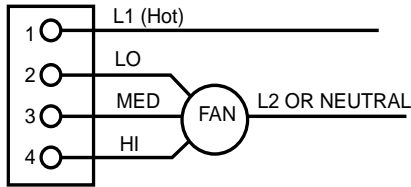

TA168-002/TA168-003 CONTINUOUS FAN

**SINGLE SPEED FAN CONTROL**

24 - 277 VAC  
VOLTAGE  
CONNECTION

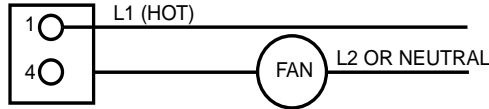

TA 168-007/TA168-008 CONTINUOUS FAN

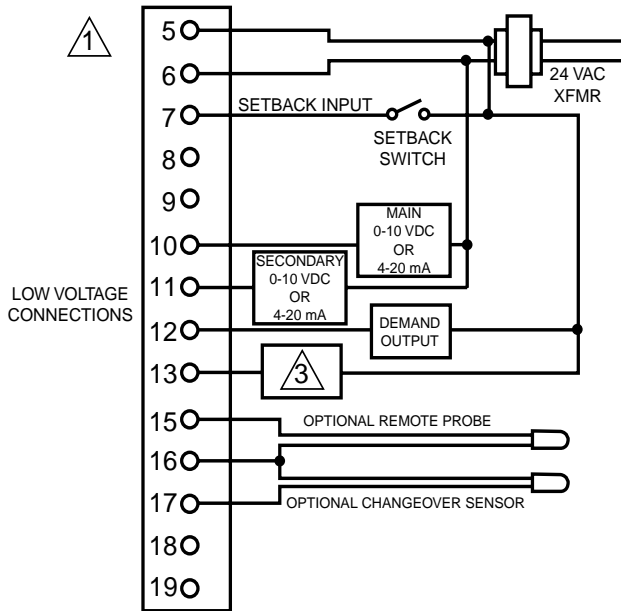

- For main and secondary outputs, Terminal 6 is the common and Terminal 5 is the power. For setback, demand and auxillary heat outputs Terminal 5 is the common and Terminal 6 is the power.
- For demand fan control, power a 24V fan relay using Terminal 12 as the output. Output limited to 10 VA.
- Can be used for second stage 24 Vac heat output or single stage 24 Vac electric heat output by setting dipswitch #2.

Figure-1 Typical Wiring.

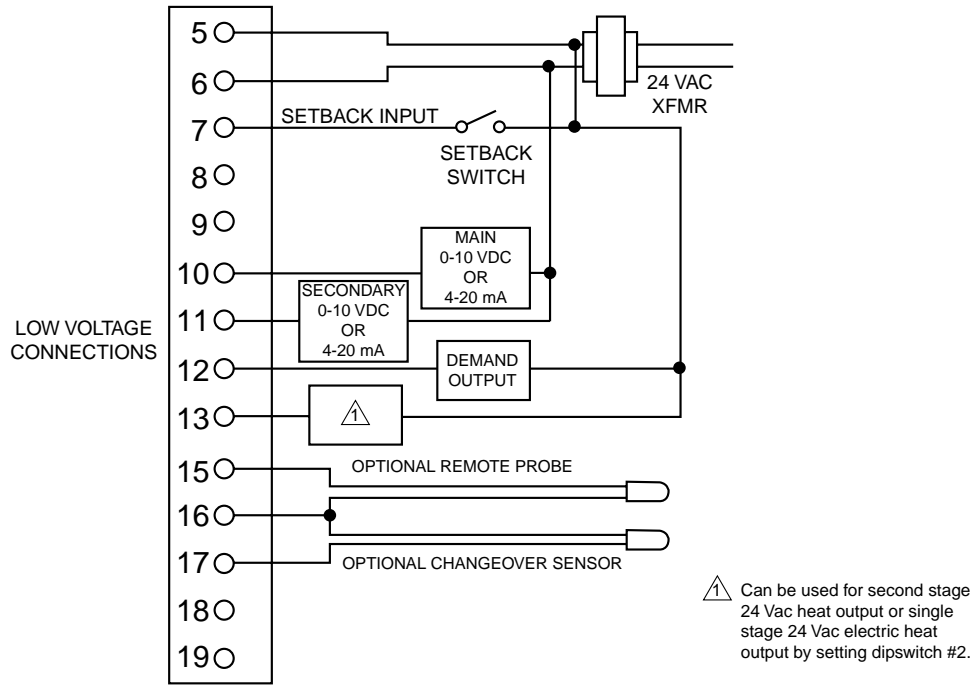

Figure-2 Typical Wiring for TA168-001 Dual Output Proportional Control.

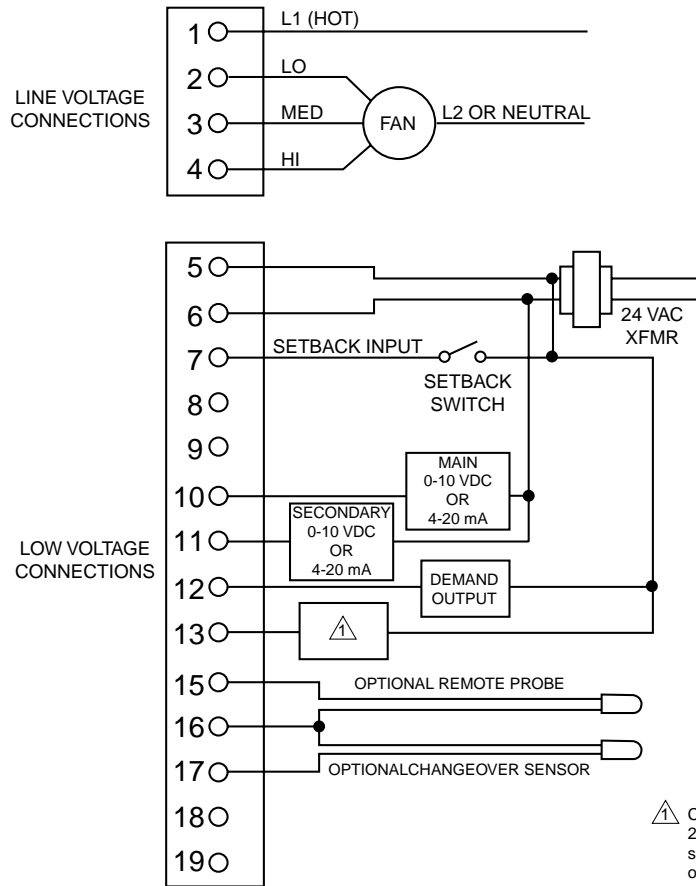

Figure-3 Typical Wiring for TA168-002 and TA168-003 Dual Output Proportional Control with Three-Speed Line Voltage Fan Control.

# INSTALLATION

## Inspection

Inspect the package for damage. If damaged, notify the appropriate carrier immediately. If undamaged, open the package and inspect the device for obvious damage. Return damaged products.

### Requirements

- Tools (not provided)
  - Digital multimeter
  - Screw driver
- Training: Installer must be a qualified, experienced technician
- Other accessories as appropriate

## Precautions

### General

#### ▼ **WARNING**

---

- Electrical shock hazard! Disconnect power before installation to prevent electrical shock or equipment damage.
  - Make all connections in accordance with the electrical wiring diagram and in accordance with national and local electrical codes.
- 

#### ▼ **CAUTION**

---

- Avoid locations where excessive moisture, corrosive fumes, explosive vapors, or vibration are present.
  - Avoid electrical noise interference. Do not install near large conductors, electrical machinery, or welding equipment.
- 

### Federal Communications Commission (FCC)

#### **NOTE**

---

This equipment has been tested and found to comply with the limits for a Class B digital device, pursuant to Part 15 of the FCC Rules. These limits are designed to provide reasonable protection against harmful interference in residential installations. This equipment generates, uses, and can radiate radio frequency energy and may cause harmful interference if not installed and used in accordance with the instructions. Even when instructions are followed, there is no guarantee that interference will not occur in a particular installation. If this equipment causes harmful interference to radio and television reception—which can be determined by turning the equipment off and on—the user is encouraged to try to correct the interference by one or more of the following measures:

- Reorient or relocate the receiving antenna.
  - Increase the separation between the equipment and receiver.
  - Connect the equipment to an outlet on a circuit different from that to which the receiver is connected.
  - Consult the dealer or an experienced radio/television technician for help.
- 

### Canadian Department of Communications (DOC)

#### **NOTE**

---

This class B digital apparatus meets all requirements of the Canadian Interference-Causing Equipment Regulations.

Cet appareil numérique de la classe B respecte toutes les exigences du Règlement sur le matériel brouilleur du Canada.

---

### European Standard EN 55022

#### ▼ **WARNING**

---

This is a class B (European Classification) product. In a domestic environment this product may cause radio interference in which case the user may be required to take adequate measures.

---

## Mounting

Mount the T168 series to a suitable surface approximately five feet above the floor on an inside wall. Standard holes are provided for mounting purposes. Do not mount on a surface that exceeds 120°F (49°C). Refer to Figure-4. Do not mount near cold or warm air drafts from doorways, windows or discharge air vents. Do not mount near lights, lamps or in direct sunlight. Do not mount behind doors or furniture. Do not mount on outside walls. Insulate behind wall plate if necessary.

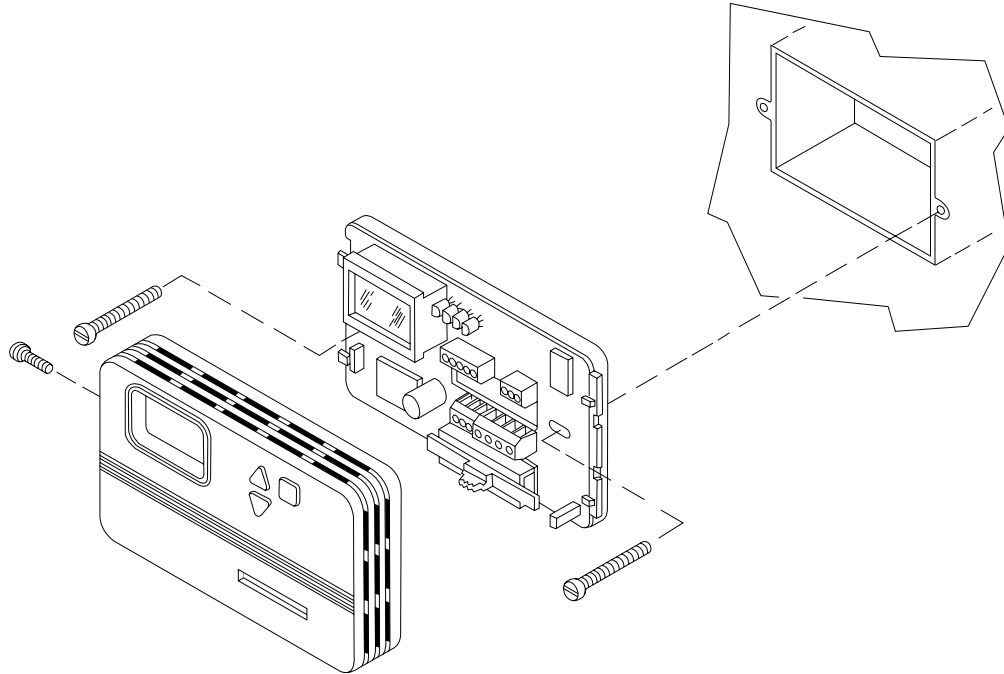

Figure-4 Mounting.

## WIRING

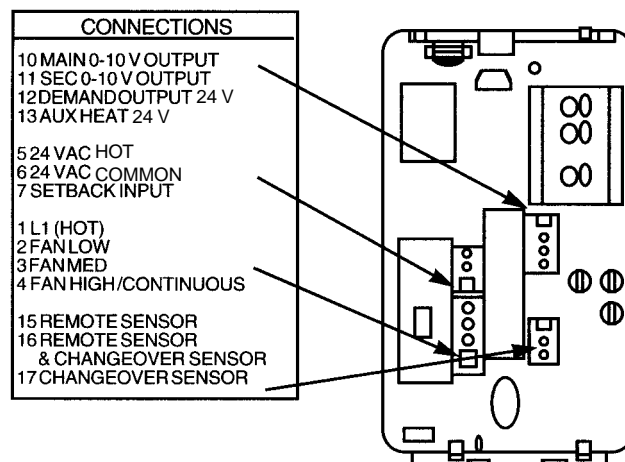
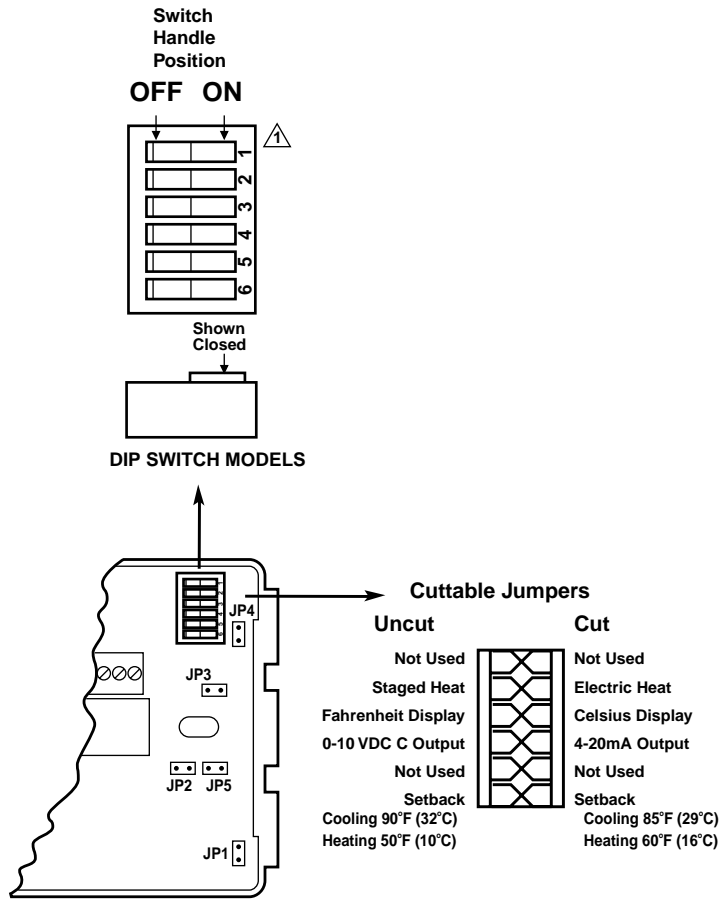

Figure-5 Terminal Definitions.



⚠ Older styles will have cuttable jumpers  
uncut = On, cut = Off

Cuttable Jumper/Dip Switch Designation	On/Uncut	Off/Cut
1	Not Used	Not Used
2	Staged Heat	Aux. On-Off Electric Heat
3	Fahrenheit Display	Celsius Display
4	Output 0-10 Vdc	Output 4-20 mA (requires the removal of JP4 and JP5)
5	Not Used	Not Used
6	Un-Occupied Set Point 90°F Cooling/50°F Heating	Un-Occupied Set Point 85°F Cooling/60°F Heating

Pin Pair Jumper Designation	Jumpered	Open
JP1	Local Sensor	Remote Sensor
JP2	2 Pipe	4 Pipe
JP3	Not Used	Not Used
JP4	Main 0-10 Vdc	Main 4-20 mA
JP5	Secondary 0-10 Vdc	Secondary 4-20 mA

Figure-6 Switches and Jumpers.

## INITIAL SETUP

### Application Notes

The T168 series thermostats are field configurable for a wide range of applications. Models built after January 2000 have configuration dip switches in the upper right corner of the circuit board. Models built before January 2000 were equipped with cuttable jumpers instead of dip switches for field configuration.

In addition to dip switches there are pin jumpers which are pairs of small pins. The pin jumper pairs are located on the right hand side of the T168 circuit board. The jumpered state means that both pins are covered by the black plastic jumper cap. In the un-jumpered (open) state the jumper cap can be stored by placing the cap over either pin of the pin pair. See Figure-6 for further information on dip switches and jumpers.

## SETTINGS

### **NOTE**

---

A single set point serves as the set point for both heating and cooling.

---

### **Cooling/Heating Output Logic**

The factory default for the main output is the cooling output and the secondary output is the heating output. Follow these steps to change the factory default.

Dual Output Models: Connect a jumper wire from terminal 16 to terminal 17 to make the main output heating only, and the secondary output is disabled.

Single Output Models: Connect a jumper wire from terminal 16 to terminal 17 to make the main output heating.

### **Seasonal Changeover Sensor**

When installing the seasonal changeover sensor strap the sensor to the main coil input or a pipe that will determine the fluid temperature of the coil. If a well is available, use thermal grease for a faster temperature response. Insulate the entire sensor and pipe 2 inches before and after the sensor for a total of approximately 6 inches. This insulation is used to decrease the affect of ambient temperature on the sensor.

When no changeover sensor is installed on terminals 16 and 17 the main output defaults to cooling logic, which controls the output for cooling purposes.

When a changeover sensor is installed the main output is cycled from heating to cooling or from cooling to heating. This depends upon the temperature measured by the changeover sensor strapped to the supply pipe or mounted in the return air duct. Refer to "Seasonal Changeover With The 65406 Sensor" in this document.

### **Remote Sensor (Room)**

Install the sensor in a location that will only measure the temperature to be sensed without any external heating or cooling sources influencing the sensor. Heating or cooling sources to avoid include direct sunlight, mounting the sensor too low or too high on a wall, and areas in ducts with dead air movement. Consider the room stratification and air movement on the remote sensor location.

When using a remote sensor remove the jumper cap from pin pair JP1, located in the lower right corner of the circuit board. This will disable the onboard sensor. You can store the jumper cap on either pin of the JP1 jumper pair.

### **NOTE**

---

Failure to remove the jumper on JP1 will enable both the onboard and the remote sensors. The T168 will not function properly.

---

### **Sensor Wire Length**

In all applications, run the sensor wire away from any electronic noise generating devices, such as motors, fluorescent lights, microwaves, or parallel to line voltage wiring. The maximum length of non-shielded wire should not exceed 25 feet. Even if the sensor wire is not near any noise generating devices, it still acts like an antenna and picks up background noise that is read by the microprocessor.

In an electronic noisy environment or if the sensor wire must be located close to noise-generating devices, always use shielded wire and connect the shielding to an earth ground. If shielded wire is used and is properly grounded, the maximum length of the shielded sensor wire should not exceed 100 feet.

- Improper wiring or mounting of sensors may cause the following:
- Sensing too high or too low of temperature.
- Delay in sensing the proper temperature.
- Not be able to sense the proper control media.
- Controllers have erratic control responses.

### **Signal Logic**

The T168 is factory configured to provide a 0-10 Vdc signal. Dip switch 3 is On and pin pairs JP4 and JP5 have the jumper cap over both pins of the pair.

For 4-20 mA signal, move dip switch 4 to the Off position, then remove jumper caps on JP4 and JP5. Jumper caps can be stored on either pin of pin pairs JP4 and JP5.

### **Demand Heat Logic**

If equipped with demand output the T168 will automatically provide a 24 V output (terminal 12) to power a fan relay any time there is a call or demand for heating or cooling. The maximum switched load is 10 VA @ 24 V.

### **Auxiliary Heat Logic**

If equipped with auxiliary heat output the T168 offers the user two options, a second stage of on/off heat, or a single stage of electric heat. In both cases the auxiliary output (terminal 13) provides 24 V, and a rated load handling ability of 10 VA. Use a relay if the load will exceed 10 VA.

**Second Stage of Heat:** To enable second stage of heat logic dip switch 2 must be in the On position. On a call for heat the first stage heat will provide the configured 0-10 Vdc or 4-20 mA signal. At 2 degrees below the set point the T168 will provide a full proportional 10 Vdc or 20 mA signal, completely opening the valve. If the temperature continues to drop to 3 degrees below the set point, the T168 will bring on the 2nd stage of heat by providing 24 V at terminal 13.

**Electric Heat:** To enable electric heat, dip switch 2 must be in the Off position. On a call for heat the T168 will provide 24 V power at terminal 13. This output will cycle in on/off mode subject to a 1 degree differential and maximum load of 10 VA at 24 V. There will still be a 3 degree deadband between heating and cooling. There will be no 0-10 Vdc or 4-20 mA heat output.

### **Setback Logic**

When in setback mode both the cooling and heating outputs operate as on/off outputs.

When dip switch/jumper 6 is in the On state the T168 controls setback is set at 90°F cooling, 50°F heating. In the Off state the setback is set at 85°F cooling, 60°F heating.

**Setback Mode:** When a dry contact closure occurs to terminal 7 on the T168 the setback mode is enabled. A building automation system or time clock can be used to provide a dry contact, unpowered circuit to terminal 7.

**Cooling Mode:** At 3 degrees above set point, the cooling device will be fully opened and will stay open until the temperature drops to the set back set point.

**Heating Mode:** At 3 degrees below the set point the heating device will be fully opened until the temperature rises to the set back set point.

**Setback Override:** When in setback mode pressing any of three buttons, up arrow, down arrow, or system mode, will force the T168 into a 1 hour override. In override the thermostat will control the temperature at the non-setback mode set point.

## **Calibration**

The T168 uses a 10K thermistor type sensor to measure temperature. As the air temperature changes, the resistance of the thermistor changes. The change in the resistance is fed into the processor and the processor adjusts the output to the control device.

Up to 5 degrees of offset can be added or subtracted.

This is a software re-calibration of the room temperature displayed by the thermostat as well

temperature value (controlled variable) which is compared to the set point in order to determine the thermostat output.

1. Supply 24 Vac to the thermostat.
2. Press the mode button, scroll the thermostat until Off mode is displayed.
3. Push the up and down arrows at the same time, hold them in the depressed position.
4. In 1 second the display will show an offset value if an offset was previously entered. If there was no offset the display will read "0.0".
5. An offset can be set up to either positive or negative 5 degrees.
  - a. To create a positive offset, release the down arrow while keeping the up arrow depressed, until the desired offset is displayed up to 5 degrees.  
Example: If the temperature sensor reads 70°F with a 5 degree positive offset the thermostat will read 75°F.
  - b. To create a negative offset, release the up arrow while keeping the down arrow depressed, until the desired offset is displayed up to 5 degrees.  
Example: If the temperature sensor reads 70°F with a 5 degree negative offset the thermostat will read 65°F.
6. When the correct offset value is displayed release both the up and down arrows.
7. After a two second delay the display will indicate the room temperature and the plus or minus offset entered.

## CHECKOUT

Verify the dip switch and jumper pin settings.

Verify that the 24 Vac is permanently available across terminal 5, hot, and terminal 6, Common.

### ▼ CAUTION

---

Make certain that all switched loads are within the 10 Va switched power maximum.

---

Verify that the action (direct or reverse) and the signal logic (0-10 Vdc or 4-20 mA) of the controlled device (valve or actuator) are consistent with the T168 signal logic. In Cooling mode, on a rise in ambient temperature, the output is ramped up. In Heating mode, on a rise in temperature the output is ramped down.

To verify the heating or cooling 0 - 10 Vdc outputs: Connect a voltmeter in parallel across terminal 6, common, and terminal 10 for cooling logic or terminal 11 for heating logic.

To verify the heating or cooling 4 - 20 mA outputs: Connect an amp meter in series with the controller output and terminal 10 for cooling or terminal 11 for heating.

To verify heating or cooling outputs when in night setback: Check for 24 Vac in parallel across terminal 6, common, and terminal 10 for cooling or terminal 11 for heating.

### NOTE

---

- In setback mode the logic is on/off not proportional.
  - The common terminal is not the same for all outputs.
- 

To verify contact closure in setback mode: Check for 24 Vac in parallel across terminals 5, common, and terminal 7, hot.

To verify the 24 Vac demand output: Check for 24 Vac in parallel across demand terminal 12 and terminal 5, common.

To verify the auxiliary heat/2nd stage heat output: Check for 24 Vac in parallel across auxiliary terminal 13 and terminal 5, common.

## THEORY OF OPERATION

### Control Algorithm

The PI control algorithm has a 2F degree proportional band. The proportional band is the amount of change required by the ambient temperature for the output to go from 0 to 100%. For example, in the heat mode, with a 70°F set point and an ambient temperature of 70°F the output is 0%; at 69°F the output is 50%; and at 68°F the output is 100%. The intergral gain implies that the longer the error between the ambient and the set point temperatures

exists, the more the output will change to eliminate the error. The intergral portion of the algorithm eliminates the temperature offset from the set point.

### Heat mode

When the ambient temperature is below the set point the output is somewhere between 0 and 100% the T168 is in "Heat" mode.

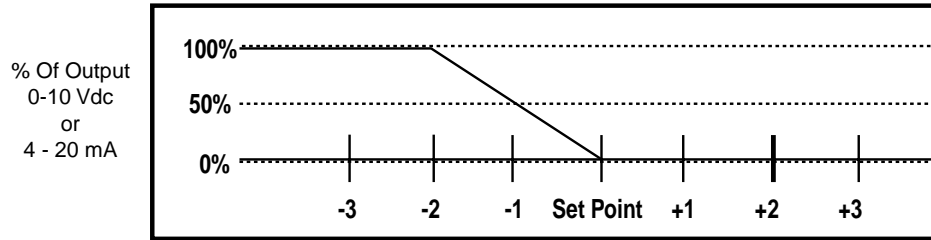

### Cool mode

When the ambient temperature is above the set point the output is somewhere between 0 and 100% the T168 is in "Cool" mode.

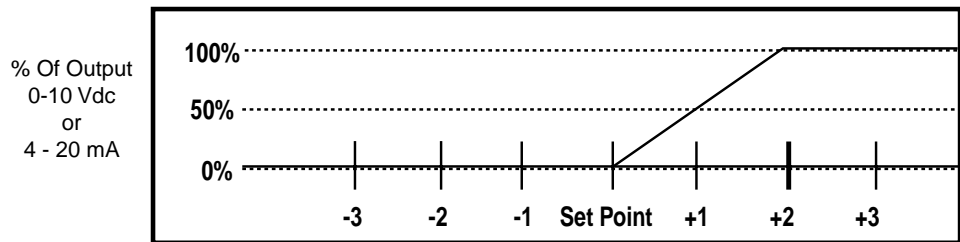

### Auto mode

Upon initial startup the controller is in the auto mode. The controller determines automatically if it should be in the "Auto-Heat" or "Auto-Cool" mode, based on the set point and the ambient temperature. When the ambient temperature is below the set point, the unit is in the "Auto-Heat" mode. When the ambient temperature reaches the set point or above by up to 3°, the unit is in the "Auto" mode. Once the ambient temperature reaches 3° past the satisfied set point the unit changes into the "Auto-Cool" mode. Since the ambient temperature is 3° past the set point, the output goes to 100%. The unit remains in the "Auto-Cool" mode until the ambient temperature reaches the set point. If the ambient temperature drops below the set point the modes changes into the "Auto" mode. When the ambient temperature reaches 3° below the set point the mode changes to the "Auto-Heat" mode.

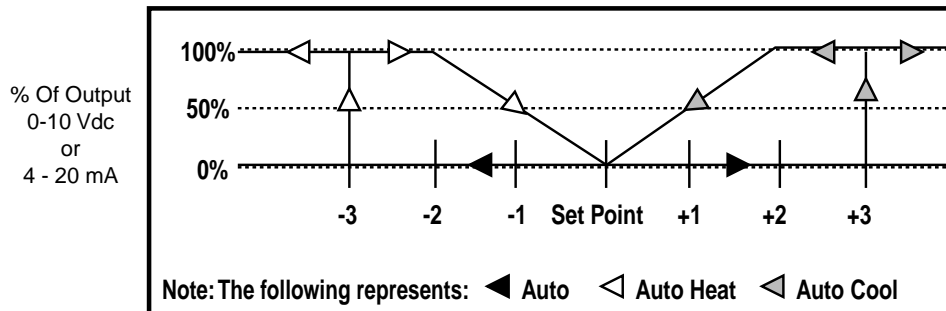

## Seasonal Changeover With the 65406 Sensor

The seasonal changeover logic will compare the sensed temperature at the pipe sensor thermistor with the actual ambient, room temperature as measured by the onboard thermistor in the thermostat.

During initial startup the thermostat determines the resistance value wired across terminals 16 and 17.

If the resistance value is:

Below 350 ohms: There is a jumper wire across terminals 16 and 17 which locks the thermostat into a heating only logic. Both the single or dual output thermostats will be configured as single output heating only thermostats. The heating output will be the main and only output. The processor will not be polled and will not check the status of the changeover terminals.

Over 350,000 ohms: With no jumper or a 65406 thermistor installed across terminals 16 and 17 the heating and/or cooling outputs will work normally. The main output is for cooling and the secondary output is for heating. The processor will not be polled and will not check the status of the changeover terminals.

Between 350 ohms and 350,000 ohms: There is a 65406 thermistor installed across terminals 16 and 17 of the thermostat. The processor will poll the resistance once every second and will then authorize the main output to control in either heating or cooling depending on the continuously changing value of the resistance.

## 2 Pipe Seasonal Changeover Sensor Operation

The TA168-004, when in summer operation, with the pipe sensor feeling cold water (15°F below thermostat ambient), the thermostat will be in Cool mode and operate the control valve for cooling. When the pipe sensor feels hot water (15°F above thermostat ambient), the thermostat will changeover to winter operation and will be in Heat mode to operate the valve for heating. Should the thermostat once again feel cold water it will change back to summer operation and be in the Cool mode.

If the controller senses that the seasonal changeover temperature is within  $\pm 15^\circ\text{F}$  of the ambient temperature, the mode is ambiguous. During this ambiguous state, if there is a demand for heating or cooling, the controller will carry out the following steps to determine if cooling or heating is available.

1. The word "Auto" is displayed indicating the ambiguous state:
  - "Auto" only indicates the ambiguous state with no demand for either heating or cooling.
  - "Auto Heat" or "Auto Cool" indicates the ambiguous state with a demand for heating or cooling based on the differential between the ambient temperature and the set point.
2. The controller operation is limited to two position control, 100% open or 100% closed.
3. With a demand for heating or cooling, a three minute timer is started for a purge cycle. During the purge cycle the control valve is fully open.
4. After purging for three minutes the controller again checks the seasonal changeover temperature for the ambiguous state. If the mode is no longer ambiguous the controller resumes normal operation.

If the mode is still ambiguous the controller does the following:

1. Continues to hold the main valve open.
2. Checks if the seasonal changeover temperature is less than 60°F or greater than 80°F. If the temperature is less than 60°F (cooling mode) or greater than 80°F (heating mode) the controller is declared to no longer be in an ambiguous state and starts to control appropriately.
3. If the temperature is between 60°F and 80°F the controller is still viewed as being in an ambiguous state and the purge continues with testing every three minutes until a non-ambiguous state occurs based on the  $\pm 15^\circ\text{F}$  criteria or the 6°F/80°F criteria.
4. Once a non-ambiguous state is detected the controller waits for a one hour before checking and allowing another purge cycle to occur. During this hour changes from heating to cooling and back are possible by pipe sensor changes of more than  $\pm 15^\circ\text{F}$  from the ambient.

On startup, if the mode is ambiguous the controller will go directly to the purge cycle rather than the normal start-up logic.

## MAINTENANCE

The T168 series requires no maintenance. Replace defective modules.

Regular maintenance of the total system is recommended to assure sustained, optimum performance.

## FIELD REPAIR

None. Replace any damaged or failed components with functional replacements.

## DIMENSIONAL DATA

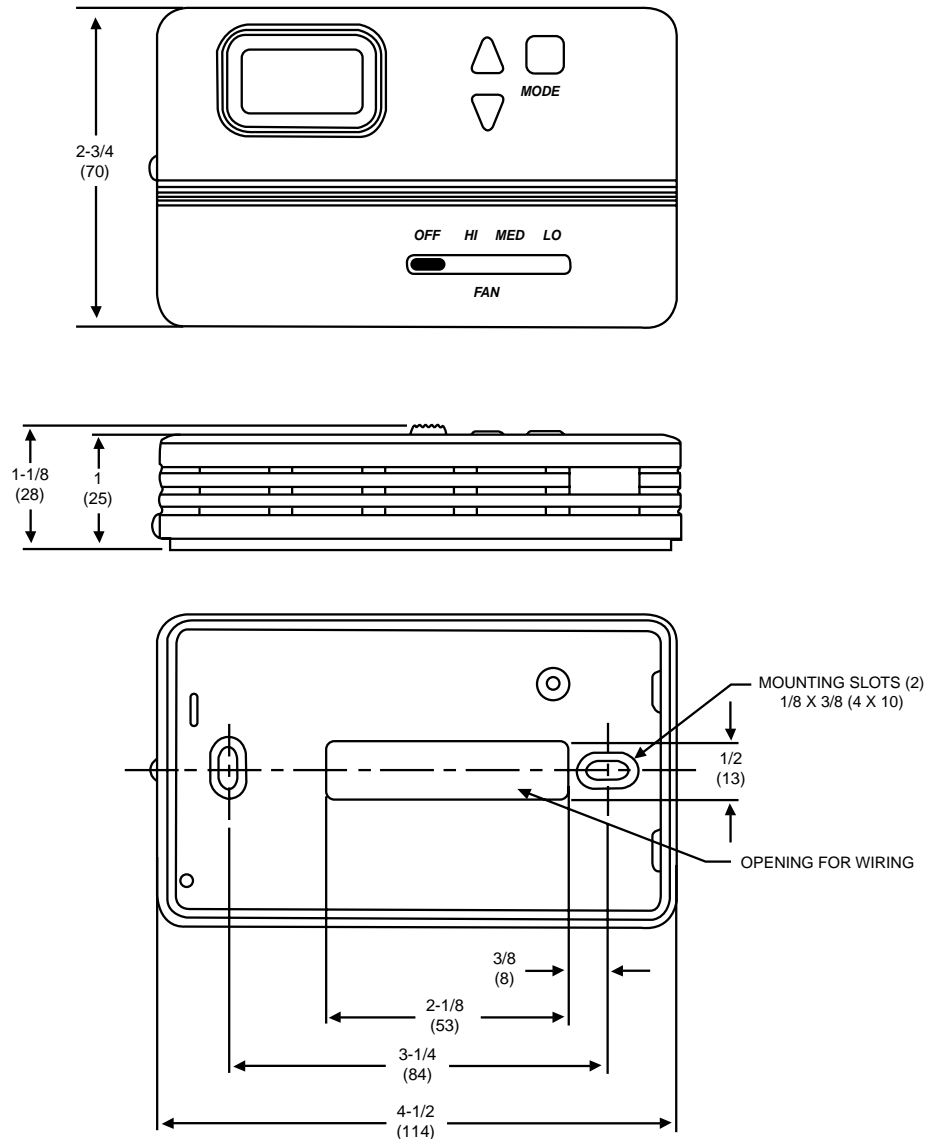

Figure-7 T168 Series Dimensions.