

**Digital, On/Off Thermostat
General Instructions****Application**

T200 series thermostats provide temperature control on a variety of heating, cooling and single stage heat pump applications.

The large LCD window displays room temperature including 1/5th of a degree increments indicated by a series of up to 5 dashes. The system heat output cycles on a 1 or 2F degree field selectable differential. The cool output differential is fixed at 2F degrees. The setpoint is displayed and changed by pressing one of the setpoint buttons up or down. Installation is simplified by having all of the field wires mounted to the separate wall plate.

This is a powered thermostat, which must receive 75 mA of power at all times.

Features

- LCD window display
- Jumper selectable 5 minute time delay for heating and cooling applications
- Mechanical contact for 40°F limit freeze protection (optional)

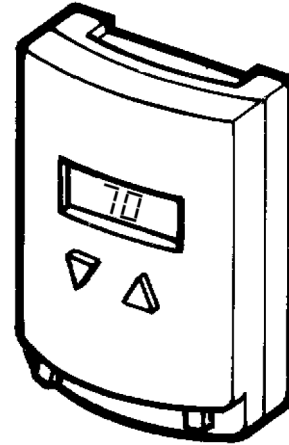

T200 Series

SPECIFICATIONS

Inputs

Power Input: 20 to 32 Vac, 75 mA to 1.2 amps.

Outputs

Electrical:

Battery, Setpoint backup (Energizer 357 or equivalent).

Mechanical:

Operating Differential, Heating 1 or 2F degrees (0.6 or 1.1C degrees), Cooling 2F degrees (1.1C degrees).

Setpoint Adjustment Range, 50 to 86°F (10 to 30°C).

Material, Rigid vinyl.

Finish, Off-white.

Environment

Temperature limits:

Shipping & Storage, -40 to 125°F (-40 to 52°C).

Operating, 40 to 125°F (5 to 53°C).

Humidity: 95% non-condensing.

Shipping Weight: 0.4 lbs (170 g).

Location: NEMA Type 1.

Table-1 Model Chart.

Model	Control Outputs	Fan Control	System Switch	Changeover	Mechanical Contact	B & O Terminals
T201	Heating Only	None	Heat/Off	None	No	No
T201-FP ^a	Heating Only	None	Heat/Off	None	Yes	No
T204	Cooling Only	On/Auto	Cool/Off	None	No	No
T205	Cooling & Heating	On/Auto	Cool/Off/Heat	Manual	No	No
T205-FP ^a	Cooling & Heating	On/Auto	Cool/Off/Heat	Manual	Yes	No
T207	Cooling & Heating	On/Auto	Cool/Off/Heat	Manual	No	Yes
T207-FP ^a	Cooling & Heating	On/Auto	Cool/Off/Heat	Manual	Yes	Yes

a On T20X-FP (freeze protection) models a relay will provide power to a valve or relay if the thermostat fails.

TYPICAL APPLICATION (wiring diagram)

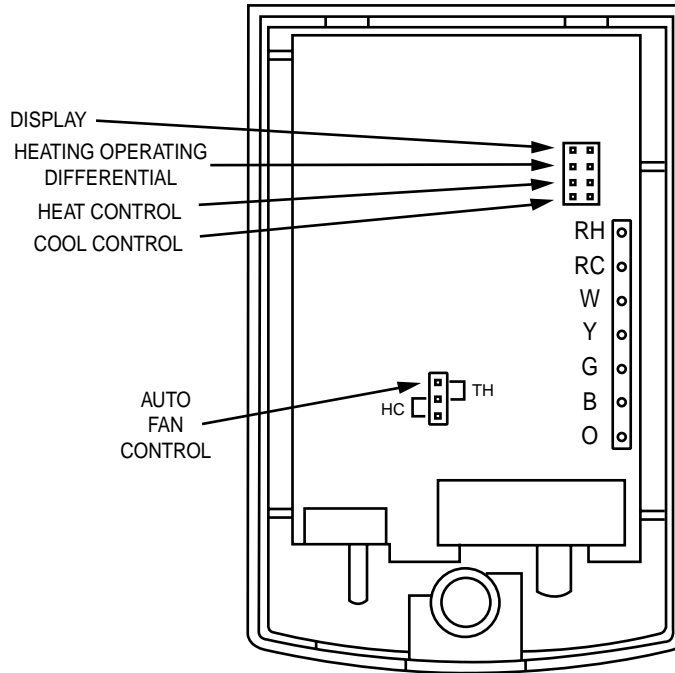

Figure-1 Terminal Identification.

Table-2 Field Selectable Jumper Options.

Feature	Jumpered	Not Jumpered
1. Display	Celsius	Fahrenheit
2. Heating operation differential	2 degrees	1 degree
3. Heat control	No delay	5 minute delay
4. Cool control*	No delay	5 minute delay

* T201, heat only model, only has jumper options 1 thru 3. A fourth jumper location exists but is non-functional in heat only models.

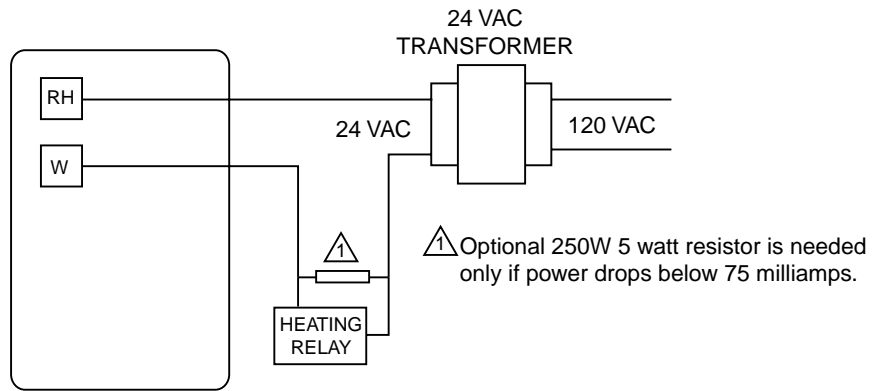

Figure-2 T201 Typical Wiring to Heating System With Single Transformer.

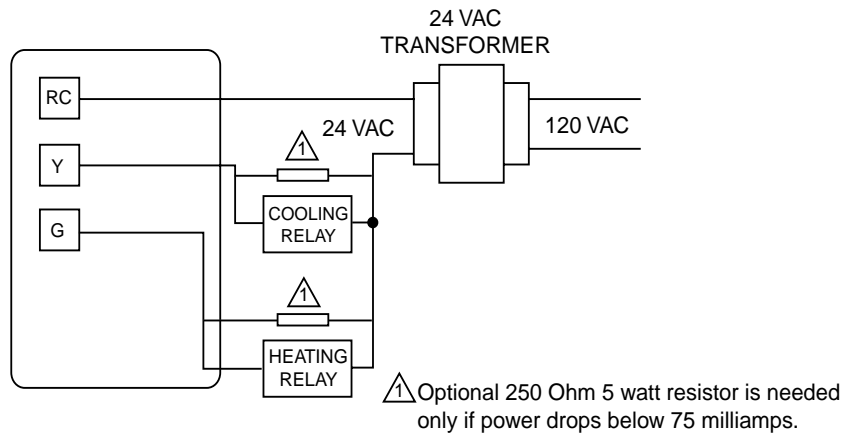

Figure-3 Typical T204 Wiring to Cooling System With Single Transformer.

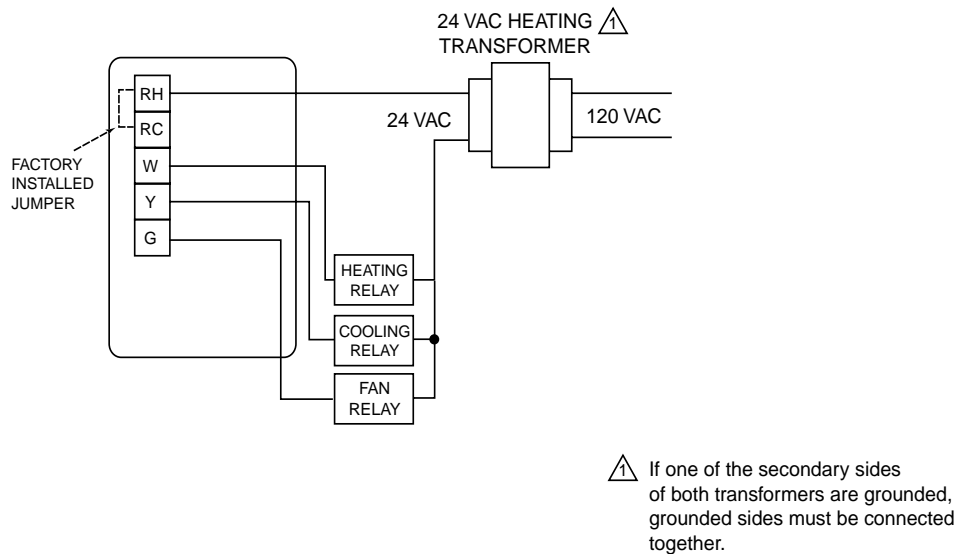

Figure-4 Typical T205 Wiring to Heating/Cooling System With Single Transformer.

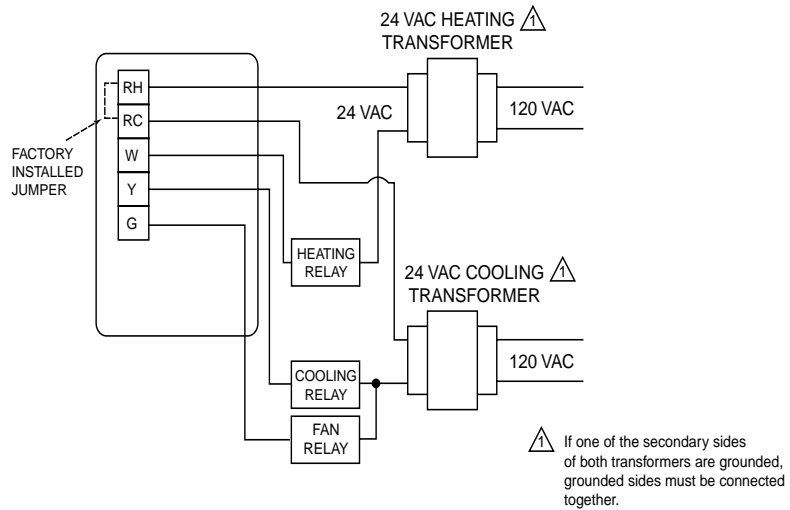

Figure-5 Typical T205 Wiring to Heating/Cooling System With Dual Transformer.

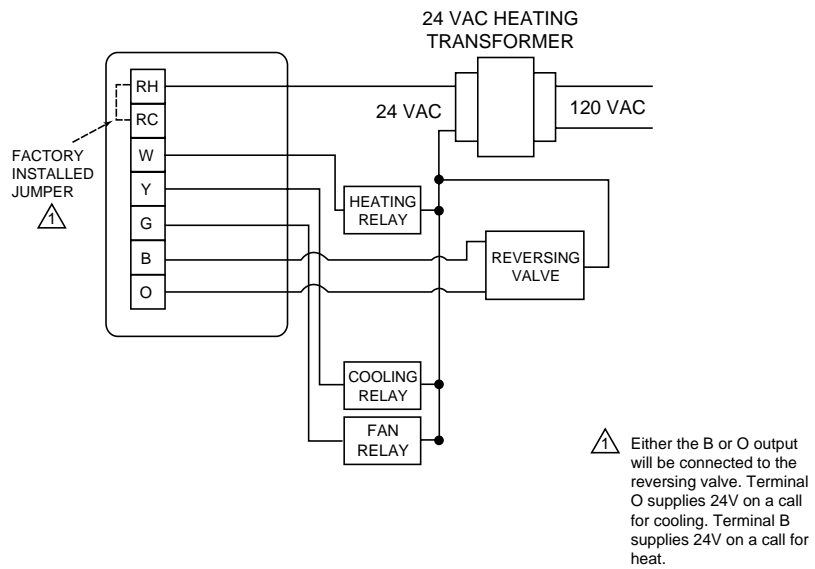

Figure-6 Typical T207 Wiring To Heating/Cooling System With Single Transformer & Reversing Valve.

INSTALLATION

Inspection

Inspect the package for damage. If damaged, notify the appropriate carrier immediately. If undamaged, open the package and inspect the device for obvious damage. Return damaged products.

Requirements

- Tools (not provided)
 - Writer's Note: Need list.
- Training: Installer must be a qualified, experienced technician
- Other accessories as appropriate

Precautions

General

▼ WARNING

- Electrical shock hazard! Disconnect power before installation to prevent electrical shock or equipment damage.
 - Make all connections in accordance with the electrical wiring diagram and in accordance with national and local electrical codes.
-

▼ CAUTION

- Avoid locations where excessive moisture, corrosive fumes, explosive vapors, or vibration are present.
 - Avoid electrical noise interference. Do not install near large conductors, electrical machinery, or welding equipment.
-

Federal Communications Commission (FCC)

NOTE

This equipment has been tested and found to comply with the limits for a Class B digital device, pursuant to Part 15 of the FCC Rules. These limits are designed to provide reasonable protection against harmful interference in residential installations. This equipment generates, uses, and can radiate radio frequency energy and may cause harmful interference if not installed and used in accordance with the instructions. Even when instructions are followed, there is no guarantee that interference will not occur in a particular installation. If this equipment causes harmful interference to radio and television reception—which can be determined by turning the equipment off and on—the user is encouraged to try to correct the interference by one or more of the following measures:

- Reorient or relocate the receiving antenna.
 - Increase the separation between the equipment and receiver.
 - Connect the equipment to an outlet on a circuit different from that to which the receiver is connected.
 - Consult the dealer or an experienced radio/television technician for help.
-

Canadian Department of Communications (DOC)

NOTE

This class B digital apparatus meets all requirements of the Canadian Interference-Causing Equipment Regulations.

Cet appareil numérique de la classe B respecte toutes les exigences du Règlement sur le matériel brouilleur du Canada.

European Standard EN 55022

▼ WARNING

This is a class B (European Classification) product. In a domestic environment this product may cause radio interference in which case the user may be required to take adequate measures.

Mounting

Mount the T200 series to a suitable surface. The T200 is shipped with an adapter plate (4-1/4 x 4-3/4 in.) that covers the mounting blemishes of a previous thermostat. New installation will not need the adapter plate. Do not mount on a surface that exceeds 125°F (52°C).

Wiring

NOTE

- The T200 series is a powered thermostat which must receive 75 mA of power at all times.
 - Some systems may require a 250 ohm, 5 watt resistor (included) to be installed across the "W" and "C" terminals of the furnace or boiler control board (Figure-2) to assure proper current draw for the thermostat. Install the resistor if the thermostat setpoint cannot be adjusted, if the heating relay cycles too often (1-15 seconds), or if the heating relay will not cycle.
 - The T200 series cannot operate with a millivolt automatic self-powered gas heating system unless an isolation relay and a separate 24 Vac transformer are used. Install an isolation relay if the ignition blower runs continuously or if the furnace will not shut off when the thermostat reaches the set temperature. Another symptom is that the furnace may not turn on.
-

T201

The T201 models are a heat only model with a "HEAT/OFF" system switch and no fan control. Applications include hydronic and radiant floor heating systems as well as gas and electric forced air heating systems. Refer to Figure-2.

T204

The T204 model is a cool only model with a "COOL/OFF" system switch and a "FAN ON/AUTO" fan switch. Applications include direct expansion cooling only systems. Refer to Figure-3.

T205

The T205 models are heat/cool models with manual changeover. The unit consists of a "COOL/OFF/HEAT" system switch and a "FAN/ON/AUTO" fan switch. Applications include hydronic heating and radiant floor heating systems as well as gas and electric forced air heating with conventional air conditioning systems. Refer to Figure-4 and Figure-5.

T207

The T207 models are heat/cool models with manual changeover and B (powered on heat demand) and O (powered on cool demand) terminals. The unit consists of a "COOL/OFF/HEAT" system switch and a "FAN ON/AUTO" fan switch. Applications include all of the T205 applications plus single stage heat pumps and forced air zoning systems that require B and O outputs. Refer to Figure-6.

For field selectable jumper options see Table-2.

For jumper and terminal locations see Figure-1.

Auto Fan Control (HC/TH)

A three-pin jumper (Figure-1) is set to enable the HC or TH mode.

The HC mode is used in electric heat applications to energize the fan relay at the same time the heating relay is energized. The TH mode is used in fossil fuel applications where the furnace, not the thermostat, controls the fan directly. In this application, a call for heat only energizes the heating relay.

Optional Freeze Protection

When the T200 thermostat is ordered with the FP option a limit switch is wired in parallel with the terminals R and W. This will provide power to a heating valve or relay if the thermostat fails. This provides freeze protection to 40°F (4°C) as long as heat is available from the heat source.

CHECKOUT

1. Verify jumper pin selections.
2. Verify that the T200 is wired correctly to your heating and or cooling loads.
3. Confirm that 75 milliamps are available at all times. To measure the current draw connect an ammeter (set to measure milliamps) in series with the heat or cool output. If power value is below 75 milliamps install a 250 ohm 5 watt resistor in parallel across the switched load. Recheck for 75 milliamps. The T200 thermostats must have 75 milliamps to function properly.
4. Verify system Heat/Cool/Fan outputs:
Heating — Connect a voltmeter in parallel across the heat output terminal, W, and common of the power source.
Cooling — Connect a voltmeter in parallel across the cooling output terminal, Y, and common of the power source.
Fan — Connect a voltmeter in parallel across the fan terminal, G, and common of the power source.
5. The display will show the current room temperature as a number. Up to five dashes will appear under the number. Each dash represents 1/5 of a degree. The thermostats ON/OFF switching is based on whole degrees.

MAINTENANCE

The T200 series requires no maintenance. Replace defective modules.

Regular maintenance of the total system is recommended to assure sustained, optimum performance.

FIELD REPAIR

Replace battery with Energizer 357 or equivalent as needed. Replace any damaged or failed components with functional replacements.

DIMENSIONAL DATA

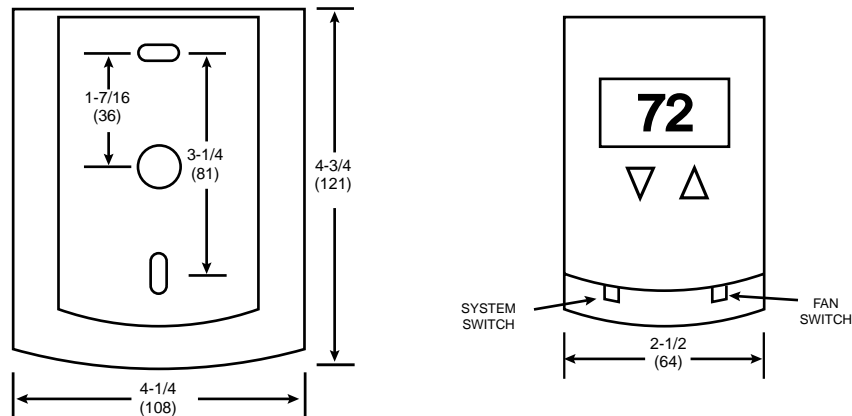

Figure-7 T200 Series Dimensions.