

**FEATURES**

- ❖ Field selectable input
- ❖ 256 step resolution with no rollover
- ❖ EMI noise filtering built into outputs
- ❖ Timing calibrated to input signal
- ❖ Optically isolated inputs

**APPLICATIONS**

- ❖ FLT/PWM to analog conversion
- ❖ DO Control of VFD's OR Damper actuators
- ❖ Analog signal transfer for DDC controllers

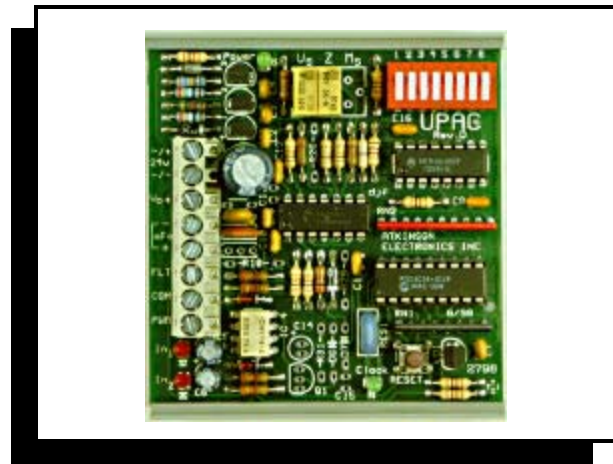

**DESCRIPTION**

The UPAC (Universal Pulse to Analog Converter) is a multi-function Interface module designed to expand the outputs of DDC Controllers or convert flow or Kw pulse rates to an analog signal. The UPAC can receive pulse inputs directly from DDC Digital outputs (DO's) or optical open collector circuits and converts the pulse-width modulated or tri-state floating signals, to an analog output. The UPAC facilitates transferring analog signals between separate DDC controllers by converting pulse outputs to 4 to 20mA, 0 to 10V DC or, adjustable V DC signals.

**OPERATION**

The UPAC consists of a 24V AC half wave rectifier, 24V, 20V and 5V DC regulated supplies, a dual opto-isolator and an amplifier section. The isolated inputs can accept either 24V AC or DC in pulse form. The UPAC module is designed to accept digital pulse-width modulated or tri-state floating inputs of various time bases and convert them to a usable analog signal. The digital inputs are optically isolated then timed by a micro controller which gives a eight bit representation of the pulse width signal. This is converted to a 0-5V DC signal and fed to the amplifier section where the signal is converted to 4 to 20mA and 0 to 10V DC. EMI noise filtering has been added to both outputs to minimize the effect of noise radiated by some VFDs on the output electronics.

**SPECIFICATIONS**

- SIZE: 3" L x 2.90" W x 1.25" H
- MOUNTING: 3" RDI snap-track (supplied). Will fit inside a 4 x 4 box.
- POWER: 24V AC  $\pm$  10%, 50/60Hz, 1.5VA  
24V DC, @ 60mA
- INPUT SIGNALS: PWM, continuous or directed, FLT (Tri-state floating).
  - 5 to 24V AC or DC pulses
  - open collector
- INPUT TIMING: PWM and Tri-State Floating timing  
2.5, 5, 10, 25, 60, 120, 255 Seconds
- OUTPUTS: 4-20mA into 600 $\Omega$  maximum  
0-10V DC or 0-5V DC, 2K $\Omega$  minimum  
Adj. 0 to 5 to 15V DC, 2K $\Omega$  minimum
- ADJUSTMENT: ZERO & SPAN  $\pm$  20%
- AMBIENT TEMP: 0 to 50°C.

**WIRING CONFIGURATION**

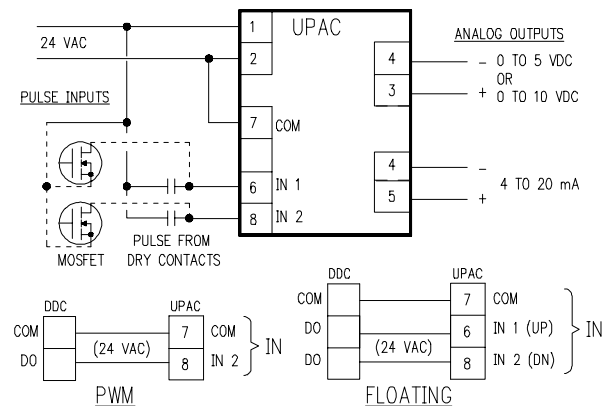

**ORDERING INFORMATION**

**PHYSICAL CONFIGURATION**

**UPAC/FP/XXX**

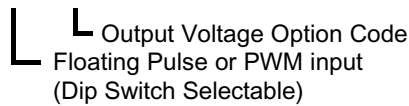

**OUTPUT VOLTAGE CODE OPTIONS**

- 10V - STD 4-20mA & 0-10V DC outputs
  - 5V - STD 4-20mA & 0-5V DC outputs
  - ADJ-V - Adj. 0-5V thru 0-15V DC outputs
  - CNT - Pulse Accumulation to 4-20mA & 0-10V DC
- \*\*See UPAC/CNT Product Sheet\*\*

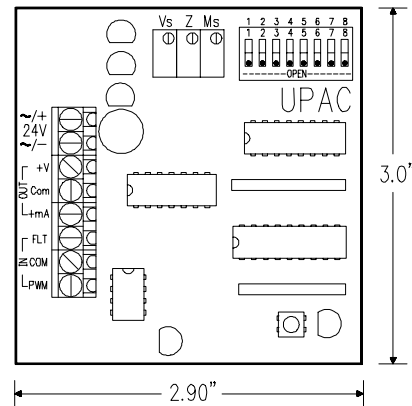

**FIELD SETUP & CALIBRATION**

The UPAC has an eight (8) position DIP switch that is used to select the type of pulse input and its time base. A logic **0** or **OFF** is when the DIP switch is in a down position towards the side marked **OPEN**. Note the DIP switch is marked to which side is open.

1. Input selection - DIP switch positions 1 & 2 (**SW1 & SW2**) are used to select input type. When both 1 and 2 are in the **OFF** position, the card will accept a tri-state floating (FLT) input. When position 1 is **ON** and 2 is **OFF**, the card will accept a PWM-C input. When positions 1 and 2 are in the **ON** position, the card will accept a PWM-D input. (See definitions below).

2. Timing selection - DIP switch positions 3 thru 8 (**SW3 thru SW8**) are used to select the pulsed input time base. ( NOTE: Only one of these six switches should be on at one time.) With all switches 3 thru 8 (**SW3 thru SW8**) in the **OFF** position, the time base is set for 255 seconds. The other time bases are detailed below:

- |   |  |   |
|---|--|---|
| Position 3 ( <b>SW3</b> ) = 2.5 seconds | Position 5 ( <b>SW5</b> ) = 10 seconds | Position 7 ( <b>SW7</b> ) = 60 seconds  |
| Position 4 ( <b>SW4</b> ) = 5 seconds   | Position 6 ( <b>SW6</b> ) = 25 seconds | Position 8 ( <b>SW8</b> ) = 120 seconds |

Voltage outputs on Standard UPAC are fixed and have no adjustment. The 4-20mA output is adjustable, and are made with the zero and Mspan potentiometers. The UPAC/ADJ voltage output is adjustable, and are made with the Zero and Vspan potentiometers. The 4-20mA and voltage adjustments are as follows:

- \* Zero adjustment clockwise, will decrease output level. Span adjustment clockwise, will increase output signal differential.
- 1- With power off connect input signal to the UPAC, select the input type and time base by setting appropriate DIP switches.
- 2- Connect multi meter in series with terminal #5 and the load for 4-20mA output. Apply power to the UPAC.
- 3- With 100% input signal applied, adjust ZERO potentiometer for 20mA output.
- 4- Adjust input signal to minimum and adjust SPAN for half of the difference of present output value and the desired 4mA output.
- 5- Repeat steps 3 & 4 until desired output is achieved.
- 6- Power down and remove multi meter from output, and power up the UPAC for normal operation.

\* Only make adjustments of  $\leq 50\%$  at a time, of the difference between the current output and the desired output.

\*\* **Note: any time the input or timing dip switches are changed the card must be reset by pressing the reset button.**

**DEFINITIONS**

**FLT** - an abbreviation for a tri-state floating signal. This signal is controlled by two digital outputs. When one of the outputs goes high, it causes an increase. When the other output goes high, it causes a decrease. When both are low or high there is no output change.

**PWM-C** - Pulse Width Modulated signals are controlled by one digital output that has a set period and whose on-time will vary within that given period. PWM-C is a signal that is continuous, which means, that at the end of every period, if there is no change in output, the same pulse width signal will be given.

**PWM-D** - Much the same as above, however, PWM-D is a directed signal. The difference being, if at the end of the period, there is no change, there will be no pulse given. PWM-D only sends a pulse when there is a change from the last value.

Call for other calibration ranges and versions.

**APPLICATION 1 - PWM OR FLT INPUT TO 4 TO 20mA CONVERSION**

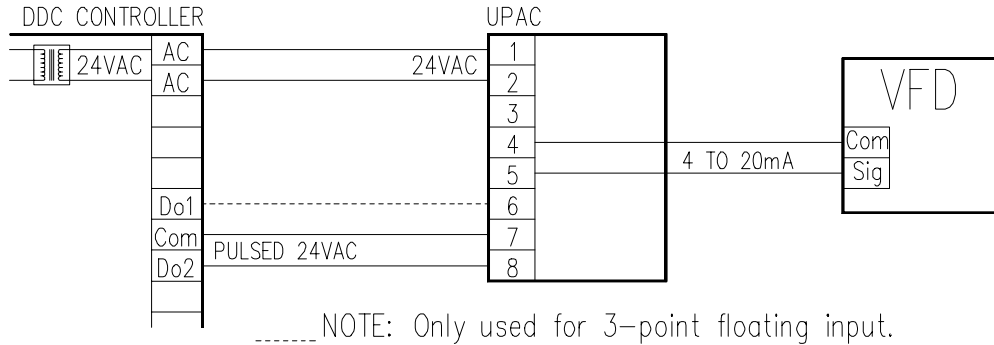

The UPAC/STD is configured for PWM or FLT input by selecting the appropriate DIP switch setting. The UPAC standard outputs are 0-10V DC and 4-20mA. In this application the 4-20mA output is used to drive a VFD. ZERO and Span Adjustment potentiometer allow for field calibration of the 4-20mA output. (See FIELD SETUP AND CALIBRATION for Dip switch settings and calibration).

**APPLICATION 2 - PWM OR FLT INPUT TO VOLTAGE CONVERSION**

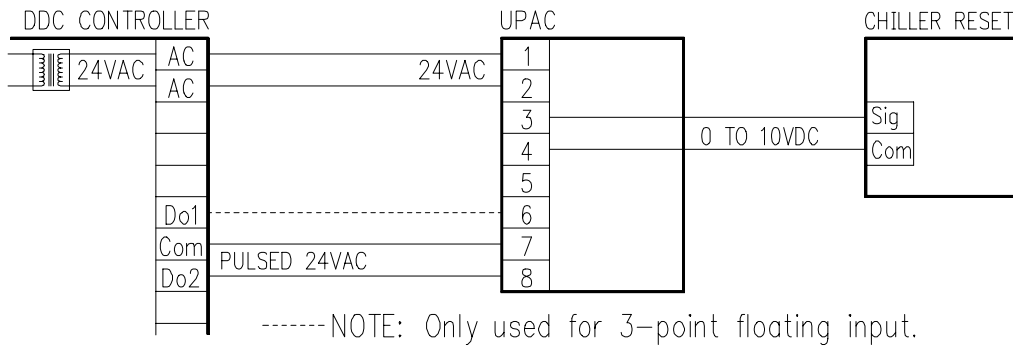

The UPAC/STD is configured for PWM or FLT input by selecting the appropriate DIP switch setting. The UPAC standard outputs are 0-10V DC and 4-20mA. In this application the 0-10V DC output is used to reset a chiller. ZERO and Span Adjustment potentiometer allow for field calibration of the 4-20mA output. (See FIELD SETUP AND CALIBRATION for Dip switch settings and calibration).

**APPLICATION 3 - PWM OR FLT INPUT CONVERSION FOR DAMPER CONTROL**

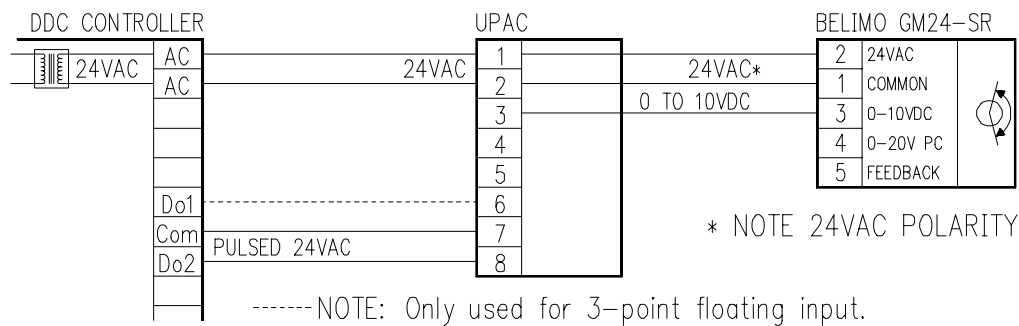

The UPAC/STD is configured for PWM or FLT input by selecting the appropriate DIP switch setting. The UPAC standard outputs are 0-10V DC and 4-20mA. In this application the UPAC's 0-10V DC output is used to drive a Belimo actuator. ZERO and Span Adjustment potentiometer allow for field calibration of the 4-20mA output. (See FIELD SETUP AND CALIBRATION for Dip switch settings and calibration).

Call for other calibration ranges and versions.

**APPLICATION 4 - PWM OR FLT INPUT TO ADJUSTABLE VOLTAGE CONVERSION**

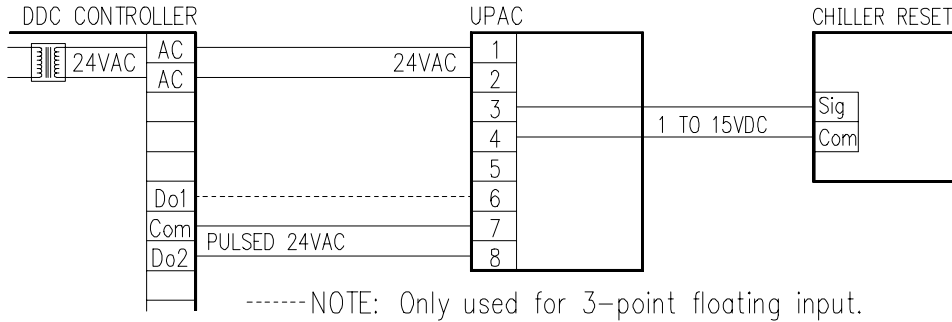

The UPAC/ADJ is configured for PWM or FLT input by selecting the appropriate DIP switch setting. The UPAC adjustable outputs are 0-5V DC thru 0-15V DC. In this application the 1-15V DC output is used to reset a chiller. ZERO and VSpan Adjustment potentiometers allow for field calibration of the voltage output. (See FIELD SETUP AND CALIBRATION for Dip switch settings and calibration).

**APPLICATION 5 - PWM OR FLT INPUT CONVERSION FOR DAMPER CONTROL**

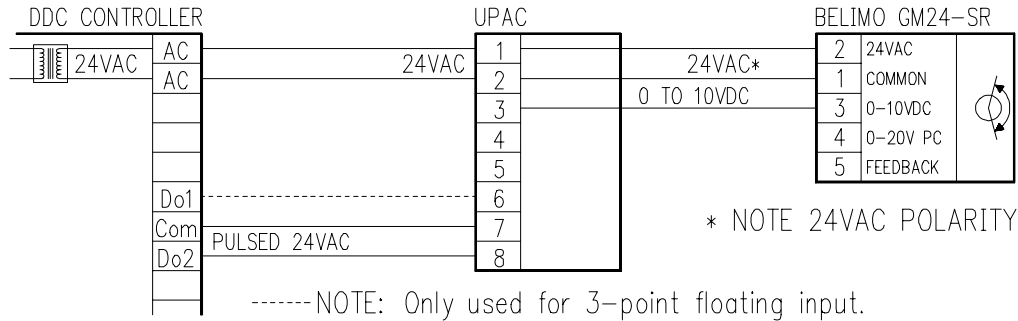

The UPAC/STD is configured for PWM or FLT input by selecting the appropriate DIP switch setting. The UPAC standard outputs are 0-10V DC and 4-20mA. In this application the UPAC's 0-10V DC output is used to drive a Belimo actuator. ZERO and Span Adjustment potentiometer allow for field calibration of the 4-20mA output. (See FIELD SETUP AND CALIBRATION for Dip switch settings and calibration).

**APPLICATION 6 - PWM OR FLT SIGNAL CONVERSION FOR THIRD CONTROL LOOP**

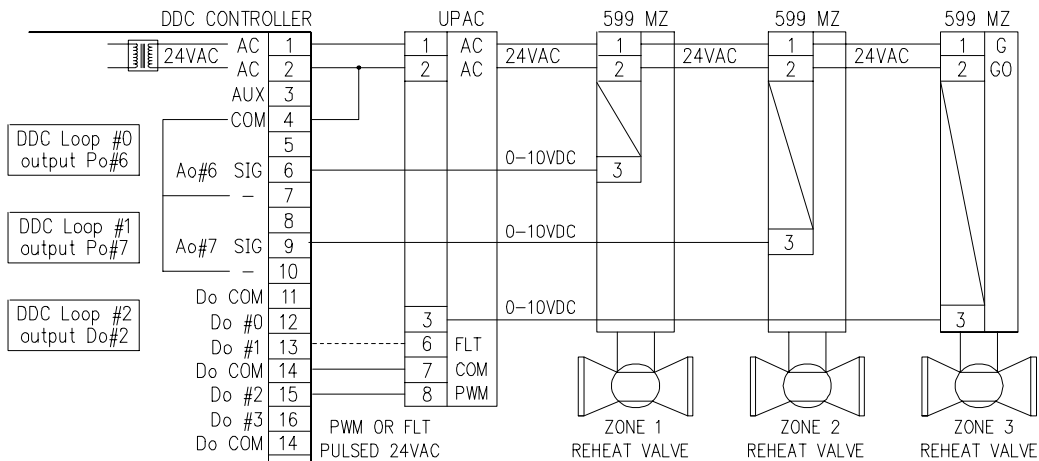

The UPAC/STD is configured for PWM or FLT input by selecting the appropriate DIP switch setting. The UPAC standard outputs are 0-10V DC and 4-20mA. In this application the UPAC's 0-10V DC output is used to drive a third Staefa's 599 MZ valve actuator.

Call for other calibration ranges and versions.