

Principle of Operation

Flow is measured in terms of dynamic force acting on a target (solid disk) in the flow stream. Hermetically sealed, bonded strain gages in a bridge circuit configuration mounted outside the flow stream translate force into an electrical output. This output is proportional to flow rate squared.



Figure 1. Target Inline Flowmeter shown with flange mounting



Figure 2. Target Inline Flowmeter shown with wafer mounting

Accessories



Figure 3. Model 1030AW Indicator/Totalizer



Figure 4. Model 1530AW Mass flow computer

Benefits

Wide Rangeability	Easily and inexpensively field modified by replacing target for extreme flow range changes
Versatile Mounting Options	Flange, MNPT, 37° Flare Tube, and more
Durable	No frictional moving parts to wear Designed to withstand 100% over range
Fast Response Time	Typically less than 2 msec.

Technical Information

Functional Specifications

Fluid Types	Steam, Gas, Liquid
Pressure:	Primary sensing elements: 1,000 - 5,000 - 10,000 psi max (69 - 345 - 690 bar) Pipe and end connections - according to appropriate ANSI or DIN specifications
Temperature:	-65° to 425° F (-54° to 218° C) std. -65° to 500° F (-54° to 260° C) extended temp. -320° to 250° F (-195° to 121° C) cryogenic -65° to 300° F (-54° to 149° C) high sensitivity (dry gases only)
Excitation Voltage (max)	15 VDC
Bridge Resistance	350 ohm \pm 5 ohm
Operational Range	Reynolds #s of >1000

Physical Specifications

Materials of Construction	
Seals	Teflon® std.; Viton, Buna-N, Grafoil
Sensing Element	316 SS/MP35N
Housing	303 SS/304 SS or 316 SS or Carbon Steel
Flanges	304 SS or 316 SS
Electronics Housing	Polyester coated aluminum
Options	Other materials
Connections & Mountings	
Mounting Position	Vertical, Horizontal, Angle
Typical Straight	Upstream: 10 x D
Pipe Requirements	Downstream: 5 x D
Process Connections	ANSI Class 150 RF to Class 2500 RF Flange AN 37° flare tube, Wafer, MNPT, DIN
Electrical Connection	¾" FNPT

Performance Specifications

Accuracy	Steam: \pm 1.0% of rate Liquid: \pm 1.0% of rate std \pm 0.5% of rate application dependent Gas: \pm 1.0% of rate
Repeatability	\pm 0.15% of rate
Flow Turndown Ratio	Steam - 10:1 Gas - 15:1 application dependent Liquid - 15:1
Response Time	0.002 to 0.1 sec (transmitter dependent)
Flow Direction	Unidirection: Standard Bidirectional: Optional - dual Model 1050 transmitters required
Agency Approvals	CSA: Class I Div 1 Groups B, C, D Class I Div 2 Groups A, B, C, D to 299 psig and 225° F FM: Class I Div 2 Groups A, B, C, D to 299 psig and 225° F

Selection and Sizing

All flowmeters are sized using an equivalent water flow. It is necessary to calculate what water flow produces a force on the target equal to the user's actual full-scale fluid flow. The following formulas are used to calculate the water flow equivalents.

Gases	$\text{gpm} = \frac{\text{SCFM}}{22.7194} \sqrt{\frac{(S_g) (T)}{P'}}$ $\text{gpm} = (1.5564) (\text{ACFM}) \sqrt{\frac{(S_g) (P')}{T}}$
Steam	$\text{gpm} = \frac{\text{pph of steam}}{63.345} \sqrt{V_g}$
Liquid	$\text{gpm} = \text{gpm}_1 \sqrt{S}$ <p>Reynolds number must be greater than 1000 throughout entire flow range for liquids</p>

Table 1

$$R_e = \frac{(3160) (\text{gpm}_1)}{(d)(v)}$$

P' = Operating pressure in psia (psig + 14.696)

gpm₁ = Full-scale gpm of actual liquid

d = Actual internal pipe diameter (inches)

v = Viscosity in centistokes

SCFM = Full-scale standard cubic feet per minute

ACFM = Full-scale actual cubic feet per minute

R_e = Full-scale Reynolds number

S = Specific gravity liquid

S_g = Specific gravity gas

V_g = Specific volume of steam in cubic feet per pound

T = Operating temperature in degrees R (degrees F + 459.67)

Note: Standard conditions are considered to be

14.696 psia and 60° F (519.67° R).

Air = 0.0764 lbs/ft³

Water = 62.3714 lbs/ft³

Flowmeter Pressure Rating

ANSI Flange Pressure - Temperature Ratings

Maximum Pressure in psig

Material	Temperature °F				
	-20 to 100	200	300	400	500
304 SS/150 # RF	275	235	205	180	170
304 SS/300 # RF	720	600	530	470	435
304 SS/400 # RF	960	800	705	630	585
304 SS/600 # RF	1440	1200	1055	940	875
304 SS/900 # RF	2160	1800	1585	1410	1310
304 SS/1500 # RF	3600	3000	2640	2350	2185
304 SS/2500 # RF	6000	5000	4400	3920	3640

Note: The ratings for slip-on and socket welding type flanges are two-thirds of the values shown.

Table 2

Target Inline Flowmeter

Flow Ranges

All flowmeters are sized using an equivalent water flow. (see Selection and Sizing on page 6)

LIQUID/GAS APPLICATION GPM EQUIVALENTS FOR FLANGED, MNPT, WAFER, & DIN METERS

Minimum and maximum flow rates to achieve accuracy

Pipe ID based on schedule 40 steel

Higher flow rates per line size available. Contact factory.

Pipe Size (in)	Pipe I.D. (in)	RANGE A				RANGE B				Full Scale PRESSURE DROP PSI (kg/cm ²)
		Min Flow GPM	Max Flow GPM	Min Flow LPM	Max Flow LPM	Min Flow GPM	Max Flow GPM	Min Flow LPM	Max Flow LPM	
0.50	0.622	0.20	3.00	0.76	11.36	2.00	30.00	7.57	113.56	14.0 (.98)
0.75	0.824	0.66	10.00	2.50	37.85	4.00	60.00	15.14	227.12	8.0 (.56)
1.00	1.049	1.50	15.00	5.68	56.78	5.33	80.00	20.18	302.82	5.0 (.35)
1.25	1.380	1.66	25.00	6.28	94.63	6.66	100.00	25.21	378.53	3.5 (.25)
1.50	1.610	2.00	30.00	7.57	113.56	7.99	120.00	30.24	454.24	2.5 (.17)
2.00	2.067	2.66	40.00	10.07	151.41	13.33	200.00	50.46	757.06	1.0 (.07)
2.50	2.469	3.33	50.00	12.61	189.27	16.66	250.00	63.06	946.33	0.8 (.06)
3.00	3.068	4.66	70.00	17.64	264.97	23.33	350.00	88.31	1324.86	0.6 (.04)
4.00*	4.026	6.66	100.00	25.21	378.53	40.00	600.00	151.41	2271.18	0.4 (.03)
5.00*	5.047	10.00	150.00	37.85	567.80	66.66	1000.00	252.33	3785.31	0.3 (.02)
6.00*	6.065	13.33	200.00	50.46	757.06	93.33	1400.00	353.28	5299.43	0.2 (.01)

* Flanged, Wafer, & DIN meters only

Table 3

STEAM APPLICATION GPM EQUIVALENTS FOR FLANGED, MNPT, WAFER, & DIN METERS

Minimum and maximum flow rates to achieve accuracy

Pipe ID based on schedule 40 steel

Higher flow rates per line size available. Contact factory.

Pipe Size (in)	Pipe I.D. (in)	RANGE A				RANGE B				PRESSURE DROP PSI (kg/cm ²)
		Min Flow GPM	Max Flow GPM	Min Flow LPM	Max Flow LPM	Min Flow GPM	Max Flow GPM	Min Flow LPM	Max Flow LPM	
0.50	0.622	0.21	2.12	0.80	8.03	2.12	21.21	8.03	80.29	7.0 (.49)
0.75	0.824	0.71	7.07	2.68	26.76	4.24	42.42	16.06	160.57	4.0 (.28)
1.00	1.049	1.06	10.61	4.01	40.14	5.66	56.56	21.41	214.10	2.5 (.18)
1.25	1.380	1.77	17.68	6.69	66.91	7.07	70.70	26.76	267.62	1.8 (.13)
1.50	1.610	2.12	21.21	8.03	80.29	8.48	84.84	32.11	321.15	1.3 (.09)
2.00	2.067	2.83	28.28	10.70	107.05	14.14	141.40	53.52	535.24	0.5 (.04)
2.50	2.469	3.54	35.35	13.38	133.81	17.68	176.75	66.91	669.05	0.4 (.03)
3.00	3.068	4.95	49.49	18.73	187.33	24.75	247.45	93.67	936.67	0.3 (.02)
4.00*	4.026	7.07	70.70	26.76	267.62	42.42	424.20	160.57	1605.73	0.2 (.01)
5.00*	5.047	10.61	106.05	40.14	401.43	70.70	707.00	267.62	2676.21	.15 (.01)
6.00*	6.065	14.14	141.40	53.52	535.24	98.98	989.80	374.67	3746.70	0.1 (.01)

* Flanged, Wafer, & DIN meters only

Table 4

LIQUID/GAS APPLICATION GPM EQUIVALENTS FOR 37° FLARE TUBE METER

Minimum and maximum flow rates to achieve accuracy

Tube ID based on copper tubing

Higher flow rates per line size available. Contact factory.

Tube Size (in)	Meter I.D. (in)	RANGE A				RANGE B				Full Scale PRESSURE DROP PSI (kg/cm ²)
		Min Flow GPM	Max Flow GPM	Min Flow LPM	Max Flow LPM	Min Flow GPM	Max Flow GPM	Min Flow LPM	Max Flow LPM	
0.50	0.391	0.13	2.00	0.50	7.57	0.67	10.00	2.52	37.85	35 (2.46)
0.75	0.609	0.20	3.00	0.76	11.36	2.00	30.00	7.57	113.56	14 (0.98)
1.00	0.844	0.66	10.00	2.50	37.85	4.66	70.00	17.64	264.97	8 (0.56)
1.25	1.078	2.00	30.00	7.57	113.56	6.66	100.00	25.21	378.53	4 (0.28)
1.50	1.312	2.66	40.00	10.07	151.41	10.00	150.00	37.85	567.80	2 (0.14)
2.00	1.781	3.33	50.00	12.61	189.27	13.33	200.00	50.46	757.06	1 (0.07)

Table 5

STEAM APPLICATION GPM EQUIVALENTS FOR 37° FLARE TUBE METER

Minimum and maximum flow rates to achieve accuracy

Tube ID based on tubing

Higher flow rates per line size available. Contact factory.

Tube Size (in)	Meter I.D. (in)	RANGE A				RANGE B				PRESSURE DROP PSI (kg/cm ²)
		Min Flow GPM	Max Flow GPM	Min Flow LPM	Max Flow LPM	Min Flow GPM	Max Flow GPM	Min Flow LPM	Max Flow LPM	
0.50	0.391	0.14	1.41	0.54	5.35	0.67	7.07	2.52	26.76	35 (2.46)
0.75	0.609	0.21	2.12	0.80	8.03	2.00	21.21	7.57	80.29	14 (0.98)
1.00	0.844	0.71	7.07	2.68	26.76	4.66	49.49	17.64	187.33	8 (0.56)
1.25	1.078	2.12	21.21	8.03	80.29	6.66	70.70	25.21	267.62	4 (0.28)
1.50	1.312	2.83	28.28	10.70	107.05	10.00	106.05	37.85	401.43	2 (0.14)
2.00	1.781	3.54	35.35	13.38	133.81	13.33	141.40	50.46	535.24	1 (0.07)

Table 6

Dimensions

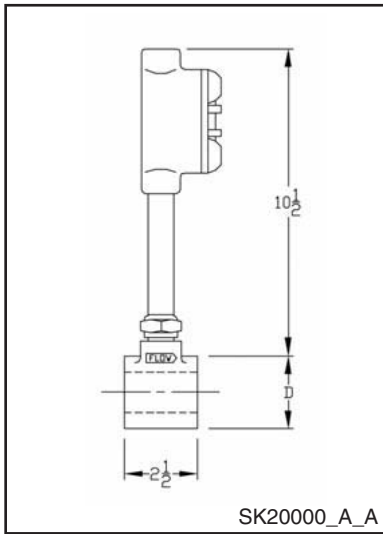

Figure 5 150 # Wafer

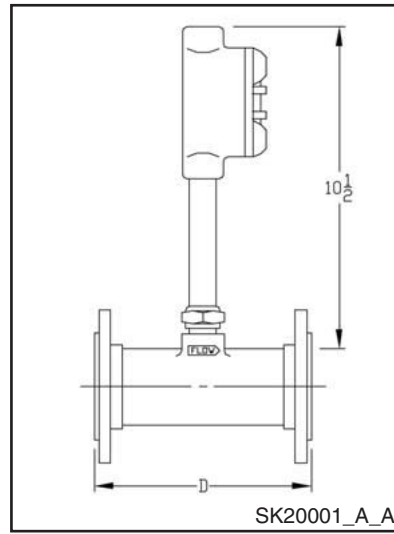

Figure 6 150# RF ANSI Flange

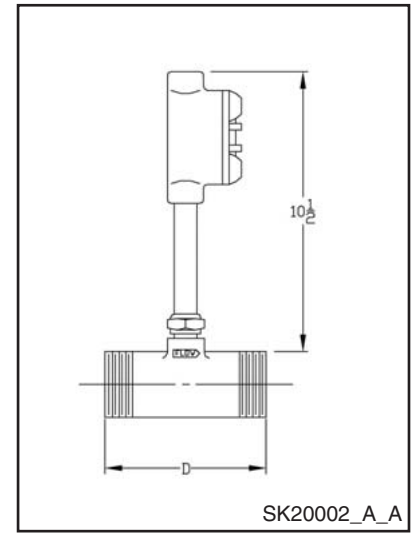

Figure 7 SCH40 MNPT

SIZE	D DIMENSION				
	Wafer	150# RF		MNPT	
		Dim.	Product Wt. (lbs.)	Dim.	Product Wt. (lbs.)
1/2"	1-3/4"	5"	8	4"	6
3/4"	2-1/8"	5"	9	4"	6
1"	2 -1/2"	5"	9	5"	6
1-1/4"	2-7/8"	6"	11	6"	7
1-1/2"	3-1/4"	6"	12	6"	7
2"	4"	8"	18	8"	7
3"	5-1/4"	9"	28	9"	9
4"	6-3/4"	10-1/2"	40	-	-
6"	8-5/8"	12-1/2"	60	-	-

Table 7

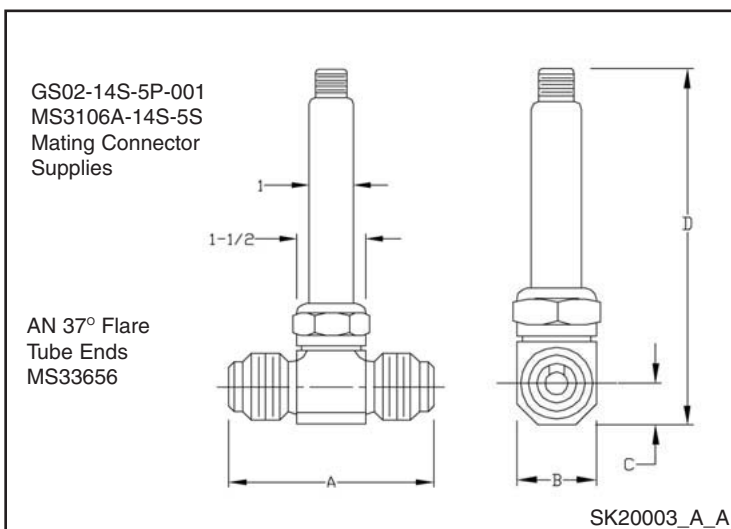

Figure 8 AN 37° Flare Tube

SIZE	DIMENSIONS				Product Wt. (lbs.)
	A	B	C	D	
1/2"	3.600"	1-3/8"	11/16"	7-5/8"	2.250
3/4"	3.600"	1-3/8"	11/16"	7-5/8"	2.250
1"	3.666"	1-3/8"	11/16"	7-5/8"	2.250
1-1/4"	3.666"	1-11/16"	7/8"	7-5/8"	2.500
1-1/2"	3.760"	1-15/16"	1"	8-1/8"	3.000
2"	4.260"	2-9/16"	1-5/16"	8-5/8"	4.500

Table 8

Ordering Information

Please provide completed application data sheet to allow us to confirm selection.

1. After calculating the water flow rate equivalent (see selection and sizing page 6), refer to the range charts on pages 7-8.
2. If the water flow rate equivalent falls between the A and B flow rate in the range charts, a 15:1 flow range of the actual user's flow may be obtained for liquids and gases, and a 10:1 flow range of the actual user's flow may be obtained for steam.
3. Select line size.
4. Select mounting connections.
5. Confirm maximum pressure capability of flange/meter rating with process conditions and select flange rating from Table 2. Wafer connections require selection of mating flange.
6. Select desired materials of construction.
7. Confirm maximum pressure requirements and select element pressure rating.
8. Confirm maximum temperature requirements and select element temperature rating.
9. Confirm suitability of standard local mounted electronics. Ambient temperature at electronics not to exceed 140° F. Select transmitter model from page 23-29. Specify if remote mounted electronics are required.
10. Provide: Fluid, Fluid Viscosity, Minimum & Maximum Operating Pressure, Minimum & Maximum Operating Temperature, Density/Specific Gravity or Specific Volume
11. Provide minimum and maximum flow range. Targets are custom sized to each application allowing a full turndown from actual maximum flow.

Model # V - - - - -

Add S For Steam _____

Line Size _____

.5 0.5" (15mm)
 .75 0.75" (20mm)
 1 1" (25mm)
 1.25 1.25" (30mm)
 1.5 1.5" (40mm)
 2 2.0" (50mm)
 3 3.0" (80mm)
 4 4.0" (100mm)
 6 6.0" (150mm)

Mounting Connections _____

A 37° Flare Tube(0.5" - 2.0")
 F Flanged
 J MNPT (0.5" - 2.0")
 W Wafer

Flange Rating _____

0 N/A
 1 150# RF ANSI (standard)
 2 300# RF ANSI
 3 400# RF ANSI
 4 600# RF ANSI
 5 900# RF ANSI
 6 1500# RF ANSI
 7 2500# RF ANSI

Max. pressure on FM meters cannot exceed 299 psig.
 Refer to flange specifications on 150# flanges.

Body Material _____

S 303/304 Stainless Steel
 Y 316 Stainless Steel

Element Pressure Rating _____

1 1,000 PSI
 5 5,000 PSI
 0 10,000 PSI

Element Temperature Rating _____

K 425° F
 T 500° F
 N -320° F
 E 300° F (high sensitivity gases only)

Options

- Remote Mount Electronics: Up to 100 ft (30m) (transmitter dependent)
- Higher Pressure Connections
- Materials of Construction – Hastelloy