

**FEATURES**

- ❖ 24V AC or DC operation
- ❖ Zero potentiometer
- ❖ Small size 1.10" by 2.19"
- ❖ Two mounting options

**APPLICATIONS**

- ❖ Converts 0 - 10V DC to 4 - 20mA to drive HVAC Actuators. (See Specifications for calibration)
- ❖ NOT for VFD applications

**DESCRIPTION**

The VMAC was designed as a low cost signal converter for those applications where HVAC DDC controllers have a 0-10V DC output without the capability of driving the current required by actuators that use a 4-20mA input signal. When the 0-10V DC is scaled to 2-10V DC the VMAC's output will be 4-20mA. The VMAC is **not** isolated and uses the same common for the input, output, and 24V AC/DC power supply common. The VMAC may be mounted in snap-track inside electrical enclosures or potted for mounting in exposed field locations.

**OPERATION**

The VMAC uses a halfwave rectifier for 24V AC/DC power, with terminal 2 being common for the power supply, input and output common (terminal 4). The input signal is reduced to 0-1V which is compared against a 0-1V generated by the 0-20mA output circuitry. The output current is independent of the load with the load resistance able to vary between zero and 600 ohms. A calibration potentiometer allows for field adjustment for a 10V input signal to correspond to 20mA output with the specific load resistance connected to the output.

**WIRING CONFIGURATION**

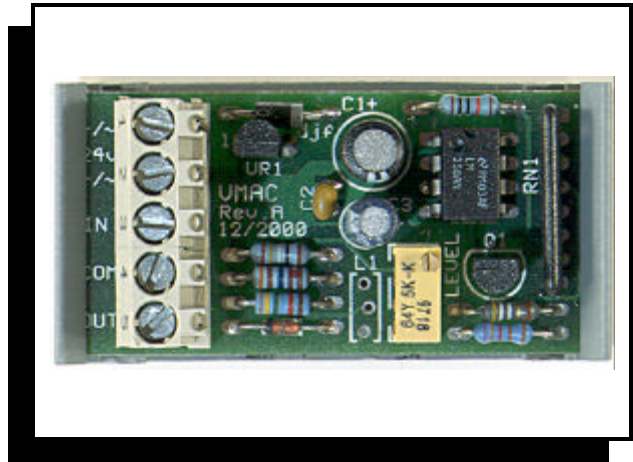
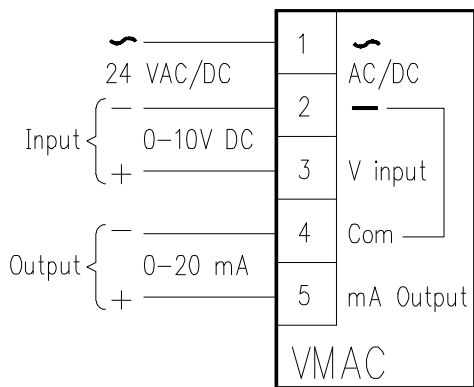

**SPECIFICATIONS**

SIZE:	1.10" L x 2.19" W x 0.75" H
MOUNTING:	2.187" RDI snap-track (supplied) or 1"W Double sided foam tape
POWER:	24V AC, ± 10%, 50/60Hz, 0.6VA 24V DC @ 45mA (or filtered DC)
INPUT:	0 to 10V DC
INPUT IMPEDANCE:	≥ 100KΩ
ACTION:	Dir. with 2 Hz filtering.
OUTPUT:	0 to 20mA - Standard Calibrated for 4 to 20mA with a 2 to 10V DC input signal. Maximum load 600Ω
ADJUSTMENT:	1 Calibration potentiometer For 20mA output @ 10V DC input.
AMBIENT TEMP:	0 to 50° C.

**ORDERING INFORMATION**

**VMAC/X**  
 └─ Mounting Option Code

**MOUNTING CODE OPTIONS**

- S - 2.187" Snap Track (Standard)
- P - Potted enclosure double stick foam tape

**PHYSICAL CONFIGURATION**

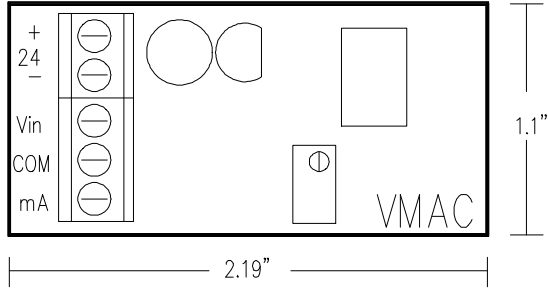

**FIELD CALIBRATION ADJUSTMENTS**

After the VMAC is connected between the DDC controller and the actuator, it may be calibrated by performing the following procedure:

1. Command the DDC output to 100% or 10V DC.
2. Connect a current meter in series with the VMAC output and actuator (load), and verify the output signal.
3. Adjust the potentiometer on the VMAC for 20.0mA output with a 10V DC input signal.
4. Command DDC output to 20% or 2V DC, and verify that the output is close to 4mA.
5. If output isn't close to 4mA ( $\pm 2\%$  of input span) you may want to calibrate for 5V DC input with 10.0mA output.

**APPLICATION 1 - VOLTAGE TO MILLIAMP CONVERSION**

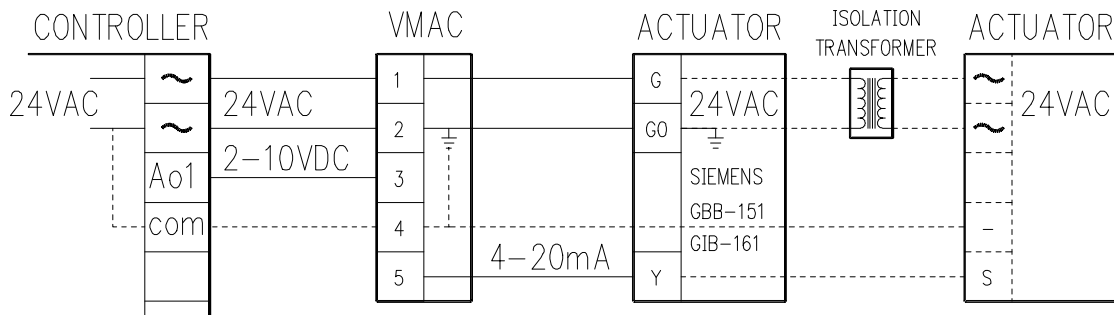

The VMAC converts a 2 to 10V DC signal from DDC controller to 4 to 20mA to drive the actuator. The actuator, VMAC, and DDC controller may be connected to the same transformer if one side of the 24V AC power is also signal common. If the signal common on the actuator is not one side of the 24V AC as shown, an isolation transformer may be needed to avoid a ground loop that may damage either or both the VMAC, actuator, or controller.

**APPLICATION 2 - MULTIPLE ACTUATOR CONNECTION**

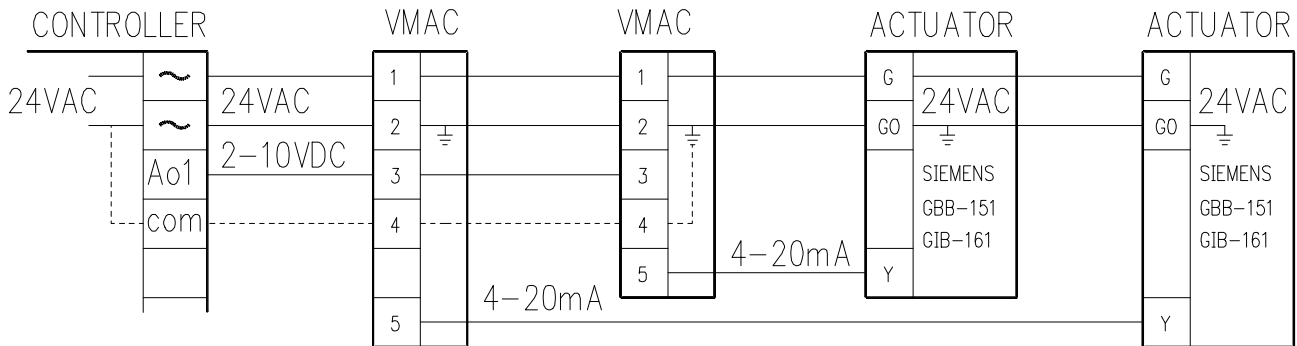

The VMAC inputs may be connected in parallel to share the same DDC 2-10V DC signal and provide individual 4-20mA signals for multiple actuators that share the same power supply. If the total resistance of the actuators is less than 600 ohms, their current inputs may be connected in series if the actuators are powered by separate transformers.

Call for other calibration ranges and versions.