



Strobe Combination Audible/Visual Signal

Model AV1ST

ECONOMICAL AUDIBLE/ VISUAL SIGNAL

- Available in 24VDC and 120VAC
- Surface mount, integrated 1/2-inch NPT pipe mount, and 4-inch electrical box mount
- Five dome colors
- Twist-off lens for easy access
- Internal buzzer produces 85dBA at 10' (95dBA @ 1m)
- Type 3R enclosure
- UL and cUL Listed and CSA Certified

Model AV1ST is a combination audible/visual signal. The AV1ST features a 100% polycarbonate housing that is rated for Type 3R rain-tight applications. Available dome colors include Amber, Blue, Clear, Green and Red.

The AV1ST design provides three mounting configurations. The black base will accommodate mounting to a 1/2-inch NPT pipe, a 4-inch octagonal electrical box or any flat surface. The surface mount gasket serves as a template for preparing a flat surface with appropriate mounting holes.

All AV1ST units feature a unique twist and lock dome design to allow for tool free access to the strobe tube. The fresnel lensing provides superior visibility in all directions.

The integrated buzzer provides 85dBA output at 10 feet (95dBA @ 1 meter).

The AV1ST comes in two voltage variations: 24VDC and 120VAC. Each unit is factory assembled with two color-coded leads. If desired, the user can remove the leads and connect directly to the terminal block located in the base of the unit. The AV1ST is UL and cUL Listed and CSA Certified.

Model	Voltage	Operating Current	Flash Rate/ Minute	Candela Peak ¹	Candela ECP ²	Decibels @ 10'	Decibels @ 1m	Mount
AV1-024_*	24VDC	0.39 amps	65-95	175,000	51.5	85	95	Pipe/Surface
AV1-120_*	120VAC	0.15 amps	65-95	175,000	51.5	85	95	Pipe/Surface

* Indicates color: (A) Amber, (B) Blue, (C) Clear, (G) Green or (R) Red

¹ Peak candela is the maximum light intensity generated by a flashing light during its light pulse

² ECP (Effective Candela) is the intensity that would appear to an observer if the light were burning steadily

LED models also available; consult your account executive.

AUDIBLE/VISUAL SIGNALING DEVICE (AV1ST)

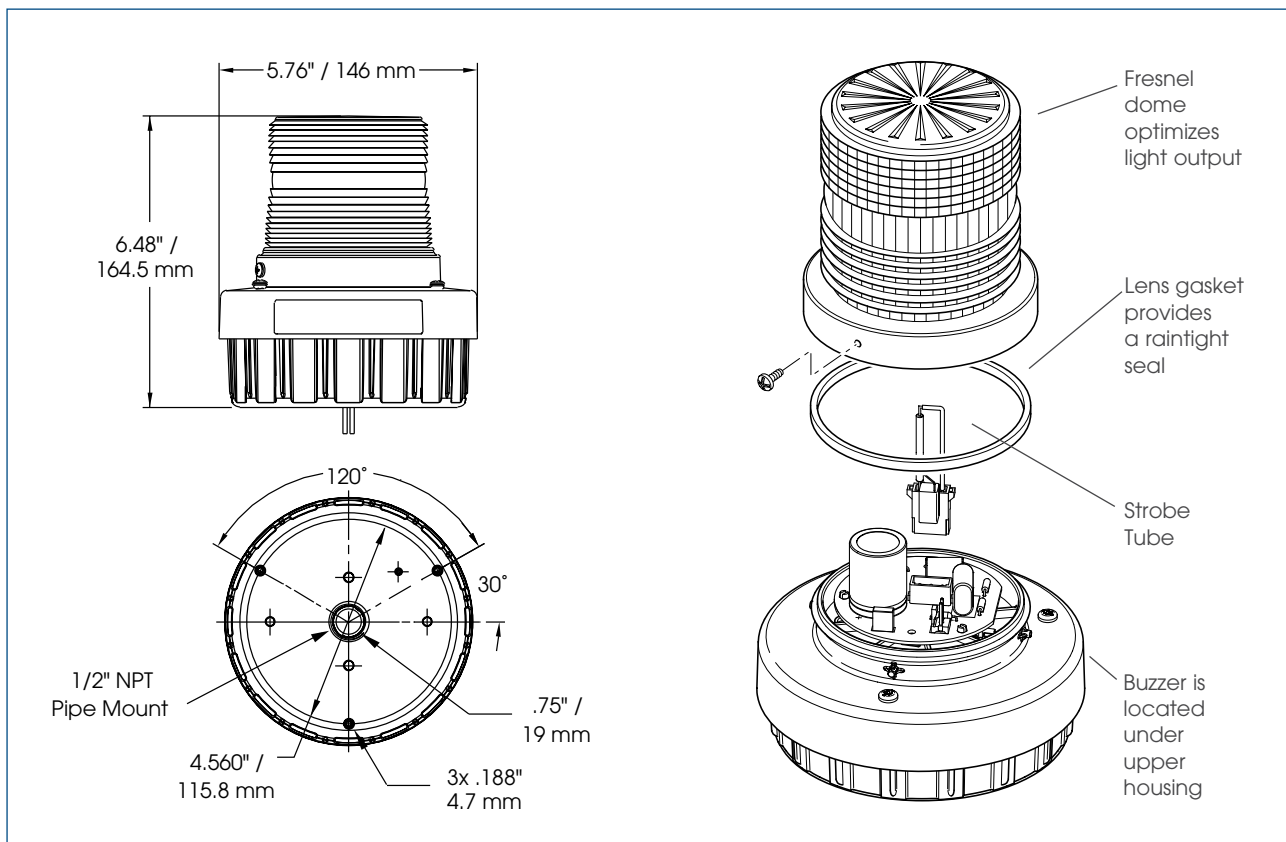

SPECIFICATIONS

Lamp Life	7000 Hours	7000 Hours
Light Source:	Strobe tube	Strobe tube
Operating Temperature:	-31°F to 150°F	-35°C to 66°C
Net Weight:	1.25 lbs.	0.57 kg
Shipping Weight:	1.75 lbs.	0.8 kg
Height (from bottom):	6.48"	164.5 mm
Diameter:	5.76"	146 mm

HOW TO ORDER

- Specify model, voltage and color
- Optional Accessories:
 Corner Bracket (LCMB2)*
 Wall Bracket (LWMB2)*
 Hazardous Location Mounting Bracket (LHWB)

* Type 3R applications.

REPLACEMENT PARTS

<u>Description</u>	<u>Part Number</u>
Dome Kit, Amber ¹	K8550292A-02
Dome Kit, Blue ¹	K8550292A-01
Dome Kit, Clear ¹	K8550292A
Dome Kit, Green ¹	K8550292A-04
Dome Kit, Red ¹	K8550292A-03
Strobe Tube	K149130A
Buzzer, 24VDC	K8591002A-01
Buzzer, 120VAC	K8591002A

WARRANTY

Limited five years

¹ Includes 1 lens gasket and 1 surface mount gasket