

Please Read Instructions Carefully Before Installation!

■ Safety

- ⚠ • This product is not intended to be used for Life or Safety applications.
- ⚠ • This product is not intended for use in any hazardous or classified locations.
- ⚡ • Disconnect and lock out all power sources before installation as severe injury or death may result from electrical shock due to contact with high voltage wires.

■ Installation

Make sure that all installations are in compliance with all national and local electrical codes. Only qualified individuals that are familiar with codes, standards, and proper safety procedures for high-voltage installations should attempt installation. The current switches will not require external power, since the power for the current switch is induced from the conductor being monitored.

- ⚠ **Warning:** Never rely on the LEDs to determine whether power is present at the current switch. The Red LED will indicate whether the current is above the adjustable trip point. The Green LED will indicate whether the current is below the adjustable trip point.

The A/ASCS Series Current Switches should be used on **Insulated Conductors Only!** The current switch may be mounted in any position using the (2) #8 x 3/4" Tek screws and the mounting holes in the base or snapped directly on to the 35mm DIN rail (See **Figures 1 & 2 below**). Leave a minimum distance of 1" (3 cm) between the current switch and any other magnetic devices such as contactors and transformers.

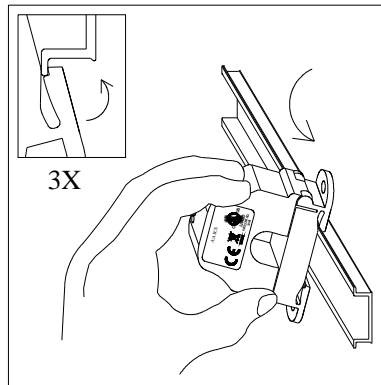

Figure 1: Sensor Placed on Rail

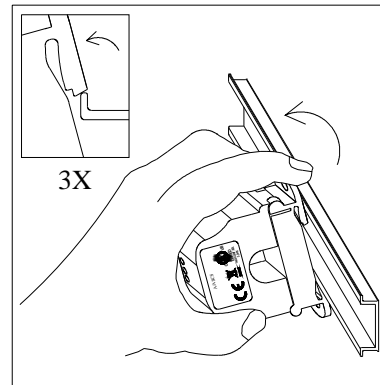

Figure 2: Sensor Removed from Rail

■ Latch Operation:

Pressing down on the two (2) side tabs and swinging the cover open opens the split core current switch as shown in **Figure 3** below. Lifting up on the latch with a flat-tip screwdriver as shown in **Figure 4** below can also open the unit. Press down firmly on the cover to close the current switch. An audible "click" will be heard as the tab slides over the tongue on the base.

- ⚠ **Caution:** Mating surfaces of the magnetic core are exposed when the sensor is open. Silicone grease, present on the cores to prevent rust, can capture grit and dirt if care is not exercised. Operation can be impaired if anything prevents good contact between pole pieces. Visually check the mating parts of the core before closing the current sensor.

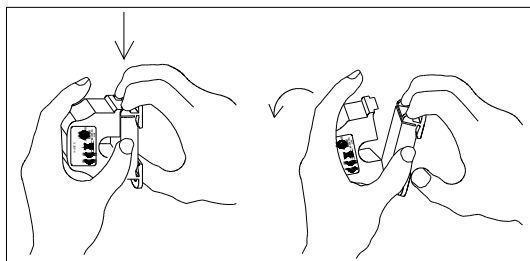

Figure 3: Opening Sensor by Hand

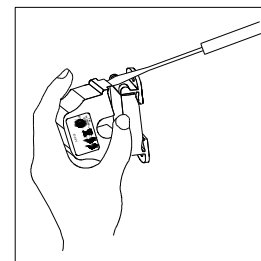

Figure 4: Opening w/ Screwdriver

For applications in which the normal operating current is below the 3.0A trip point (See Figure 5 below), the conductor being monitored may be looped through the sensor 12 times giving you a total operating current of 12X the original current. Example: A small fan operating at 0.2A should be wrapped through the sensor 18 times to give you a total operating current Of 3.6Amps flowing through the A/ASCS or another option is to use the A/ASCS-L.

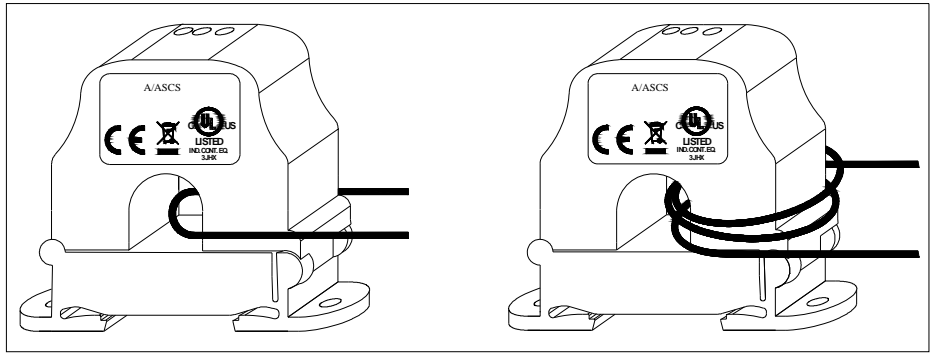

Figure 5: Wire Through Sensor

For applications in which the normal operating current is greater than 200 or 250 Amps (see operating specifications below) or for conductor diameters larger than 0.750” (1.90 cm) in diameter, an external 5 Amp Current Transformer must be used as shown in Figure 6 below.

⚡ Remember that the secondary of the 5A CT must be shorted together before the power may be turned onto the monitored device.

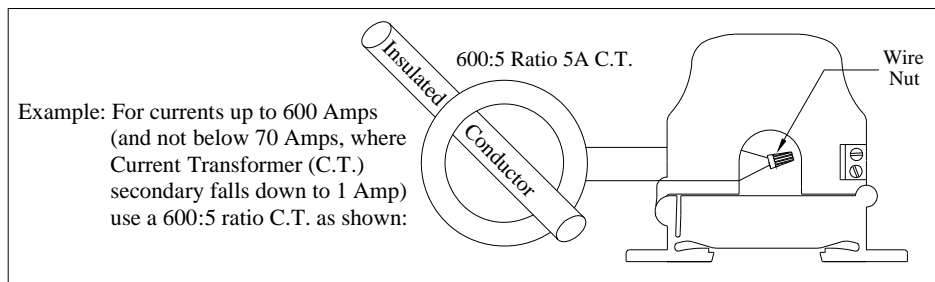

Figure 6: Current Transformer

■ **Wiring**

INTEC recommends the use of a two conductor 16 to 22 AWG shielded cable or twisted pair **copper wire only** for all current switch applications. A maximum wire length of less than 30 meters (98.4 feet) should be used between the A/CS Series current switches and the Building Management System or controller. **Note: When using a shielded cable, be sure to connect only (1) end of the shield to ground at the controller. Connecting both ends of the shield to ground may cause a ground loop.** When removing the shield from the sensor end, make sure to properly trim the shield so as to prevent any chance of shorting. The current switch output terminals represent a solid-state switch for controlling AC and DC loads and is not polarity sensitive. The recommended torque to be used on the terminal block connections is 0.67 Nm or 5.93 in-lbs.. The aperture (hole) size of the current switch is 0.75” (1.90 cm) and will accept a maximum cable diameter of 350 MCM’s.

■ **Operating Specifications**

Model #	Adjustable Trip Point	Output Switch Rating	Max. Sensing Current Voltage	Max. Continuous Current	Max. Current for 6 seconds	Max. Current for 1 second
A/ASCS	3.00 - 250 Amps	0.30Amps @ 200VAC/VDC	600 VAC	200 Amps	400 Amps	800 Amps
A/ASCS-L	2.00 - 250 Amps	0.30Amps @ 200VAC/VDC	600 VAC	200 Amps	400 Amps	800 Amps
A/ASCSX	3.00 - 250 Amps	0.15Amps @ 300VAC/VDC	600 VAC	250 Amps	500 Amps	1,000 Amps
A/ASCSX-L	2.50 - 250 Amps	0.15Amps @ 300VAC/VDC	600 VAC	250 Amps	500 Amps	1,000 Amps

See **Figure 7** and **Figure 8** for two different current switch applications using your Building Management System (DDC/PLC Controller). **Figure 7** is showing the use of the Adjustable Current Switch as a Digital Input to your DDC Controller, whereas **Figure 8** is showing you how to use the Adjustable Current Switch in conjunction with your building management system to monitor belt loss on a motor.

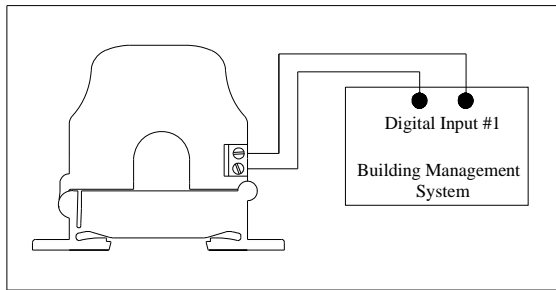

Figure 7: Digital Circuit

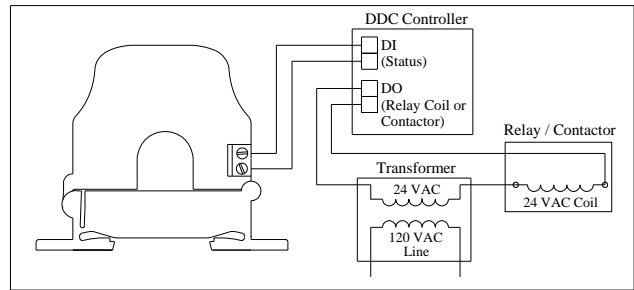

Figure 8: Analog Circuit

■ **Calibration of Adjustable Trip Point**

The adjustable current switch has an operating range of 0 to 200 or 0 to 250 Amps depending on the model being entered (see **Figure #9**). **Do not exceed!** The adjustable current switch comes with its fifteen-turn adjustment potentiometer set counter clockwise to the maximum 200 or 250A trip point position. The adjustable current switch can monitor Under load, Normal Load, and Overload conditions, depending on how it's set. The procedure below is for the Normal load condition for part numbers A/ASCS & A/ASCS-L.

■ **Normal Loads**

With power on, and the adjustable current switch on the proper range, turn the 15-turn adjustment potentiometer clockwise until the Red LED turns on and stop immediately. The adjustable current switch is now tripped. The adjustable current switch Hysteresis (Dead Band) is 10% of the trip point typically.

■ **Troubleshooting**

Problem	Solution
Red LED is on but the current switch didn't activate	Disconnect the wires from the current switch output. Measure the resistance across the contacts with an Ohmmeter. See Figure 9 for resistance readings for a good unit.
Red LED didn't turn on and the current switch didn't activate	Verify that the conductor you are monitoring is above the adjustable trip point. If the sensor is monitoring less than the adjustable trip point See Figure 5 on Page 2.
Current Switch doesn't switch at all, regardless of current level.	Adjustment potentiometer is probably set to its maximum or minimum position. Turn the Pot counter-clockwise all the way and verify if the LED switches from Red to Green.

Model #	Resistance if switch open	Resistance if switch closed
A/ASCS	Greater than 1 Meg ohms	Approximately 2 ohms
A/ASCS-L	Greater than 1 Meg ohms	Approximately 2 ohms
A/ASCSX	Greater than 1 Meg ohms	Approximately 12 ohms
A/ASCSX-L	Greater than 1 Meg ohms	Approximately 12 ohms

Figure 9

■ **WEEE Directive**

At the end of their useful life the packaging and product should be disposed of via a suitable recycling centre. Do not dispose of with household waste. Do not burn.

