

Please Read Instructions Carefully Before Installation!

■ Safety



- This product is not intended to be used for Life or Safety applications.
- This product is not intended for use in any hazardous or classified locations.
- Disconnect and lock out all power sources before installation as severe injury or death may result from electrical shock due to contact with high voltage wires.

■ Installation

Make sure that all installations are in compliance with all national and local electrical codes. Only qualified individuals that are familiar with codes, standards, and proper safety procedures for high-voltage installations should attempt installation. The current switches will not require external power, since the power for the current switch is induced from the conductor being monitored.

The A/MCS and A/MSCS Current Switches should be used on **Insulated Conductors Only!** The current switch may be mounted in any position using the (2) #8 x 3/4" Tek screws and the mounting holes in the base. Leave a minimum distance of 1" (3 cm) between the current switch and any other magnetic devices such as contactors and transformers.

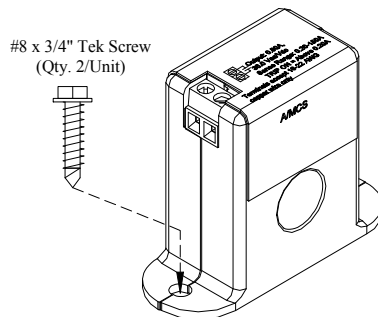

Figure 1: A/MCS

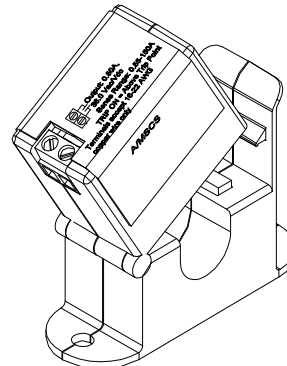

Figure 2: A/MSCS

For applications in which the normal operating current is below the 0.20 Amps (A/MCS) or 0.55 Amps (A/MSCS) trip point (See **Figure 3** below), the conductor being monitored may be looped through the sensor 4 times giving you a total operating current of 4X the original current. **Example:** A small fan operating at 0.2A should be wrapped through the sensor 4 times to give you a total operating current of 0.8Amps flowing through the A/MCS or A/MSCS.

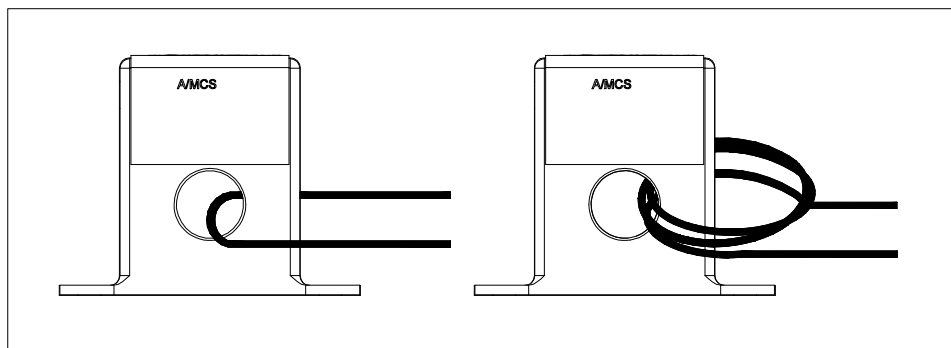

Figure 3: Wires Through Sensors

⚡ For applications in which the normal operating current is greater than 150 Amps or for conductor diameters larger than 0.530" (1.35 cm) in diameter, an external 5 Amp Current Transformer must be used as shown in **Figure 4** below. Remember that the secondary of the 5A CT must be shorted together before the power may be turned onto the monitored device.

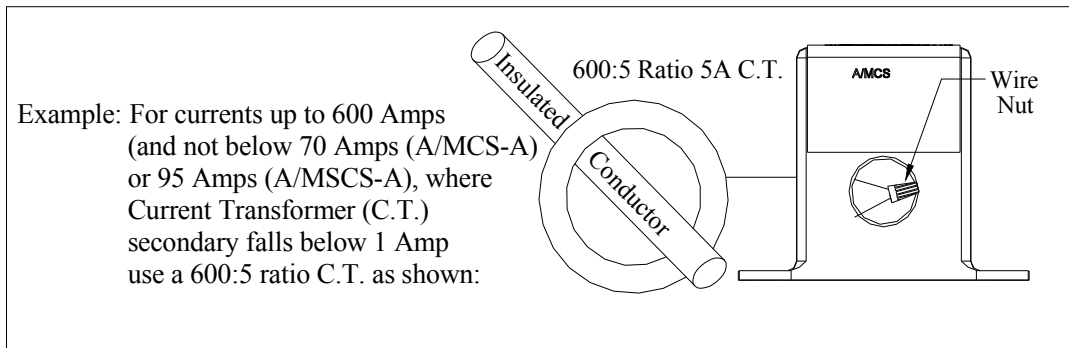

Figure 4: Current Transformer

■ Wiring

INTEC recommends the use of a two conductor 16 to 22 AWG shielded cable or twisted pair **copper wire only** for all current switch applications. A maximum wire length of less than 30 meters (98.4 feet) should be used between the A/MCS and A/MSCS current switches and the Building Management System or controller. **Note: When using a shielded cable, be sure to connect only (1) end of the shield to ground at the controller. Connecting both ends of the shield to ground may cause a ground loop.** When removing the shield from the sensor end, make sure to properly trim the shield so as to prevent any chance of shorting. The current switch output terminals represent a solid-state switch for controlling both AC and DC loads and is not polarity sensitive. The recommended torque to be used on the terminal block connections is 0.67 Nm or 5.93 in-lbs.. The aperture (hole) size of the current switch is 0.53" (1.35 cm) and will accept a 1 AWG maximum wire diameter.

■ Operating Specifications

Model #	Adjustable Trip Point	Output Switch Rating	Max. Sensing Current Voltage	Max. Continuous Current	Max. Current for 6 seconds	Max. Current for 1 second
A/MCS	0.20 - 150 Amps	0.50 Amp @ 36 VAC/VDC	600 VAC	158 Amps	240 Amps	600 Amps
A/MSCS	0.55 - 150 Amps	0.50 Amp @ 36 VAC/VDC	600 VAC	158 Amps	240 Amps	600 Amps

See **Figure 5** and **Figure 6** for two different current switch applications using your Building Management System (DDC/PLC Controller). **Figure 5** is showing the use of the Go/No Go Current Switch as a Digital Input to your DDC Controller, whereas **Figure 6** is showing you how to use the Go/No/Go Current Switch in conjunction with your building management system to control a fan or pump for example.

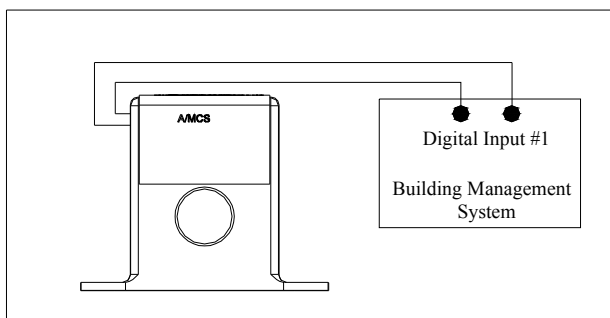

Figure 5: Digital Circuit

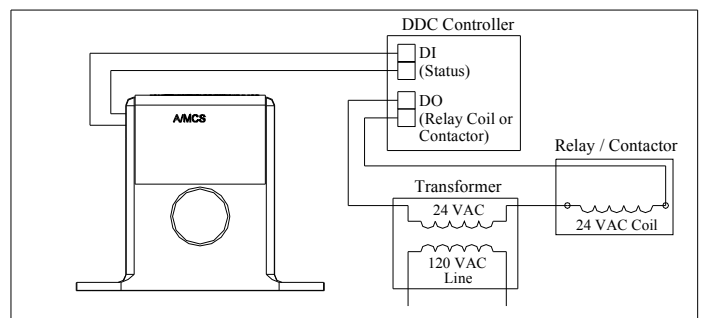

Figure 6: Analog Circuit

■ Troubleshooting

Problem	Solution
Current switch didn't activate (Test # 1)	Disconnect the wires from the current switch output. Measure the resistance across the contacts with an Ohmmeter. See Figure 7 below for resistance readings for a good unit.
Current switch didn't activate (Test # 2)	Verify that the current flowing in the conductor being monitored is above the fixed trip point as listed in the operating specifications. If the sensor is monitoring less than the fixed trip point See Figure 3 on Page 1.

Model #	Resistance if switch open	Resistance if switch closed
A/MCS	Greater than 1 Meg ohms	Approximately 0.2 ohms
A/MSCS	Greater than 1 Meg ohms	Approximately 0.2 ohms

Figure 7

■ WEEE Directive

At the end of their useful life the packaging and product should be disposed of via a suitable recycling centre. Do not dispose of with household waste. Do not burn.

