

Please Read Instructions Carefully Before Installation!

■ **Safety**

- ⚠ • This product is not intended to be used for Life or Safety applications.
- ⚠ • This product is not intended for use in any hazardous or classified locations.
- ⚡ • Disconnect and lock out all power sources before installation as severe injury or death may result from electrical shock due to contact with high voltage wires.

■ **Installation**

Make sure that all installations are in compliance with all national and local electrical codes. Only qualified individuals that are familiar with codes, standards, and proper safety procedures for high-voltage installations should attempt installation. The current sensor is a 2-wire Loop Powered device that requires a regulated +12 to 30VDC external power source.

The A/SCTA Series Analog Current Sensors should be used on **Insulated Conductors Only!** The current sensors may be mounted in any position using the (2) #8 x 3/4" Tek screws and the mounting holes in the base or snapped directly on to the 35mm DIN rail (See Figures 1 & 2 below). Leave a minimum distance of 1" (3 cm) between the current sensor and any other magnetic devices such as contactors and transformers.

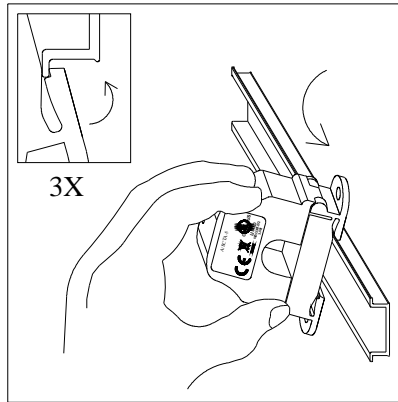

Figure 1: Sensor Placed on Rail

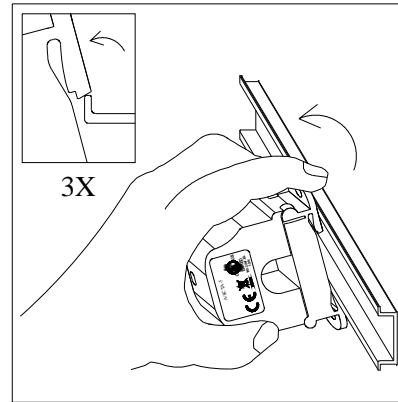

Figure 2: Sensor Removed from Rail

■ **Latch Operation:**

Pressing down on the two (2) side tabs and swinging the cover open opens the split core current sensor as shown in **Figure 3** below. Lifting up on the latch with a flat-tip screwdriver as shown in **Figure 4** below can also open the unit. Press down firmly on the cover to close the current sensor. An audible “click” will be heard as the tab slides over the tongue on the base.

- ⚠ **Caution:** Mating surfaces of the magnetic core are exposed when the sensor is open. Silicone grease, present on the cores to prevent rust, can capture grit and dirt if care is not exercised. Operation can be impaired if anything prevents good contact between pole pieces. Visually check the mating parts of the core before closing the current sensor.

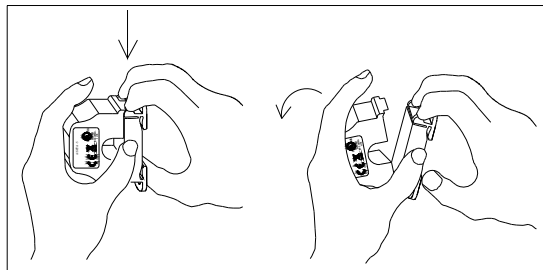

Figure 3: Opening Sensor by Hand

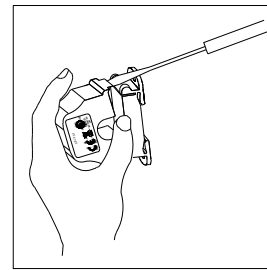

Figure 4: Opening w/ Screwdriver

For applications in which the normal operating current is greater than 200 Amps or for conductor diameters larger than 0.750" (1.90 cm) in diameter, an external 5 Amp Current Transformer must be used in conjunction with an A/CTA-5 or A/CTA-5-VFD as shown in **Figure 5** below.

⚡ Remember that the secondary of the 5A CT must be shorted together before the power may be turned on from the device.

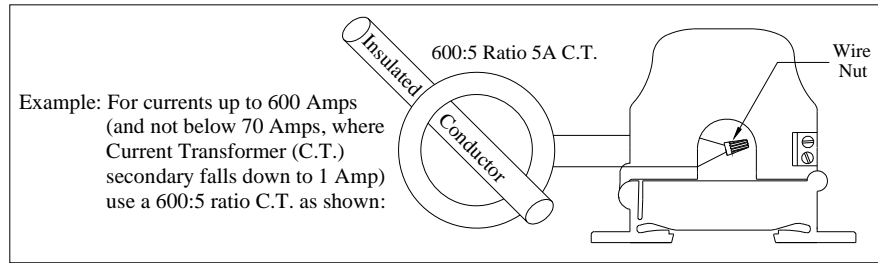

Figure 5: Current Transformer

■ Wiring

INTEC recommends the use of a 2 conductor 16 to 22 AWG shielded cable, **copper wire only** for all current sensor installations. A maximum wire length of less than 30 meters (98.4 feet) should be used between the A/SCTA Series current sensors and the Building Management System or controller. **Note: When using a shielded cable, be sure to connect only (1) end of the shield to ground at the controller. Connecting both ends of the shield to ground may cause a ground loop.** When removing the shield from the sensor end, make sure to properly trim the shield so as to prevent any chance of shorting. The current sensors terminals are polarity sensitive and represent a linear and proportional 4 to 20mA output signal. The current sensors are available in either an Average or True RMS output version. The recommended torque to be used on the terminal block connections is 0.67 Nm or 5.93 in-lbs. The aperture (hole) size of the current sensor is 0.75" (1.90 cm) and will accept a maximum cable diameter of 350 MCM's.

■ Operating Specifications

Model #	Range	Jumper *	Max. Sensing Current Voltage	Max. Continuous Current	Max. Current for 6 seconds	CE Compliant
A/SCTA-5	0-5 Amps	None	600 VAC	100 Amps	125 Amps	Yes
A/SCTA-50	0-10 Amps 0-20 Amps 0-50 Amps	Low Middle High	600 VAC	100 Amps 150 Amps 200 Amps	125 Amps 225 Amps 300 Amps	Yes
A/SCTA-200	0-100 Amps 0-150 Amps 0-200 Amps	Low Middle High	600 VAC	135 Amps 180 Amps 250 Amps	200 Amps 300 Amps 400 Amps	Yes
A/SCTA-5-VFD **	0-5 Amps	None	600 VAC	60 Amps	100 Amps	No
A/SCTA-50-VFD **	0-10 Amps 0-20 Amps 0-50 Amps	Low Middle High	600 VAC	60 Amps 100 Amps 160 Amps	80 Amps 200 Amps 300 Amps	No
A/SCTA-200-VFD **	0-100 Amps 0-150 Amps 0-200 Amps	Low Middle High	600 VAC	135 Amps 180 Amps 250 Amps	200 Amps 300 Amps 400 Amps	No

*Note: All current sensors are shipped from the factory with the jumper set in the high range.

** Note: All -VFD models have True RMS outputs and should be used with Variable Frequency Drives

Wiring Example

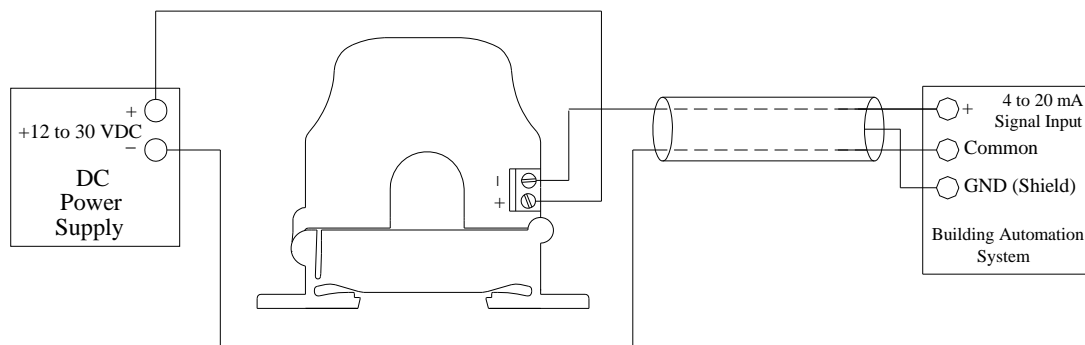

■ Troubleshooting

Problem	Solution
No reading	<ul style="list-style-type: none"> - Confirm that you have +12 to 30VDC in series with the current sensor output terminals and the analog input of the control panel. - Check the polarity of the circuit. - Verify that the terminals are screwed down, wires are firmly in place. - Disconnect the input to the control panel and then insert a current meter (mA range) in series with the current sensor output to verify that the circuit is working properly.
Erratic readings	<ul style="list-style-type: none"> - Verify that the wires are terminated properly. - Check that the +12 to 30VDC input is clean. In areas of high RF interference, shielded cable may be necessary to stabilize signal.
Inaccurate readings	<ul style="list-style-type: none"> - If you suspect that the current sensor is not reading within the accuracy specifications, please contact the factory for assistance.

■ Current Conversion Formulas

To convert the current sensor output signal to a current reading.

4-20mA output to Current reading (4mA = 0 Amps and 20mA = 200 Amps for A/SCTA-200)

Example: 12mA current sensor output signal

Total Span = 200 Amps

Multiplier = $20\text{mA} - 4\text{mA} / 200$ (Total Span) = 0.08

$(12\text{mA} - 4\text{mA}) / 0.08 = 100$ Amps

■ WEEE Directive

At the end of their useful life the packaging and product should be disposed of via a suitable recycling centre. Do not dispose of with household waste. Do not burn.

