

GA-T135-024

Direct coupled, non-spring return actuators, 135 in-lb

User Manual

July, 2003

page

1 Application	4
2 Safety remarks	4
3 Installation.....	4
4 Position indication.....	5
5 Version with 2 auxiliary switches	5
6 Wiring configuration	6
7 Parallel control of two or more actuators	7
8 Dimensions	8
9 Ordering information.....	8
10 Specifications	9

Direct coupled, non-spring return actuators, 135 in-lb

1 Application

Actuators to be easily installed by direct shaft mounting on air dampers, shutters and butterfly valves in ventilation and air conditioning systems. Can be controlled by any compatible electric or electronic analog controller DDC/PLC control or automation system. The actuators should be mounted indoors in a dry environment, relatively free from corrosive fumes.

2 Safety remarks

The actuators are not suitable for use in explosive atmospheric applications!

All service to the actuators (mounting, electrical connection, retrofitting and repair) must be carried out with the power supply disconnected. The electrical connection must be done by a trained and competent person considering the wiring diagrams, local and national regulations. Use copper twisted conductors only. Provide disconnect and overload protection if necessary.

This actuator may only be operated by 24 VAC/VDC!

The transformer **must** be sized according to technical data of the actuator (see section 10).

Always read the controller installation instructions before making any connection!

3 Installation

Direct mounting with V-bolt clamp to the damper shaft (diagr. 1) and fixing with enclosed anti-rotation mounting bracket (diagr. 2).

Shaft: Ø 5/16" to 5/8" (Ø 8 - 16 mm)

□ 5/16" to 15/32" (□ 8 - 12 mm)

- Turn the damper until the blades are closed
- Disengage the gears by pressing the red button and rotate the clamp until the switching position indication shows 90°
- Tighten the nuts on the clamp (4 - 6 ft-lb)

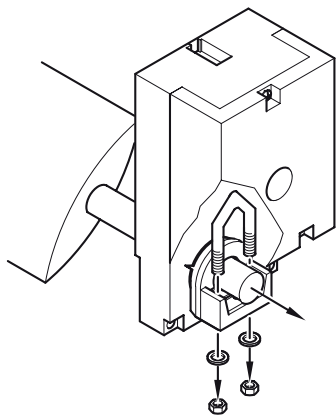

diagram 1

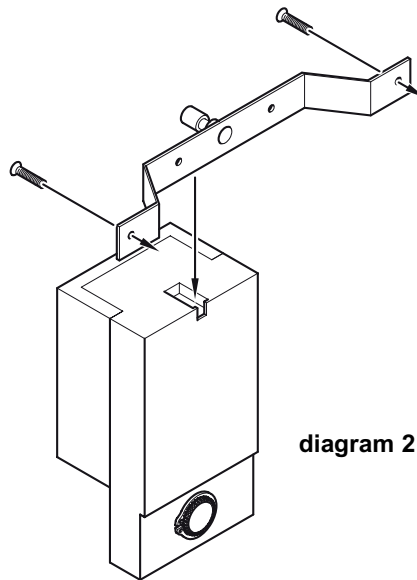

diagram 2

If the damper shaft is too short:

Proceed as in diagram 3:

- Remove the snap ring
- Pull out the V-bolt clamp assembly from the actuator towards outside
- Push the V-bolt clamp assembly from the opposite face
- Refit the snap ring

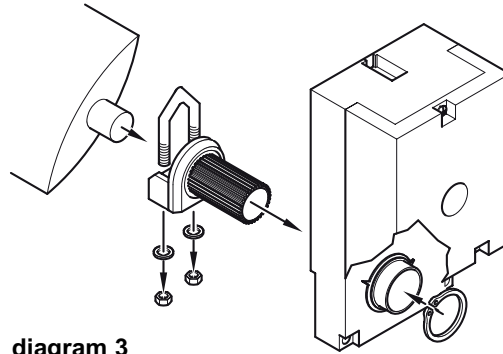
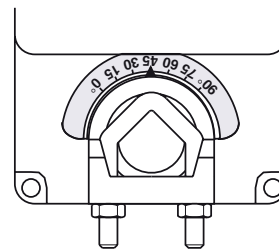

diagram 3

4 Position indication

The damper position can be seen from the scale 0° - 90°.



5 Version with 2 optional auxiliary switches

The cams of the 2 optional auxiliary switches are adjusted to 0° and 90°.

They also can be adjusted to customer request, with the option to be adjusted by the customer himself. To do so, the trigger cam is regulated by turning the screw adjuster in the cam ring.

To do so, the actuator has to be disconnected!

They can be adjusted at any position.

The auxiliary switches are only for switching 24 VAC!

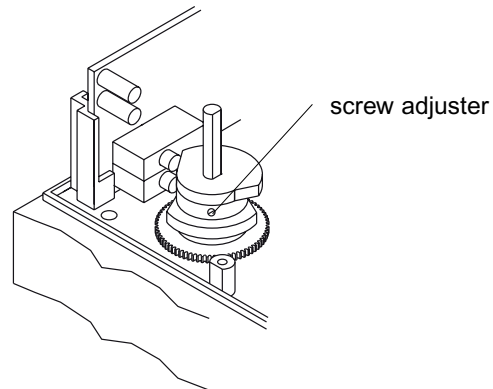

6 Wiring configuration

Notes:

- Actuators are provided with color coded wires. Wires for optional switches and feedback pot are number coded.
- Observe polarity on secondary of transformers. Incorrect polarity can cause controller damage or operation error.
- Provide overload protection for line voltage and disconnect as required.

GA-T135-024

Tri-state
(3-point floating) control

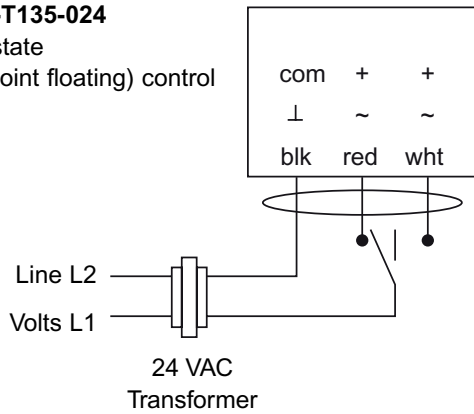

Option S2

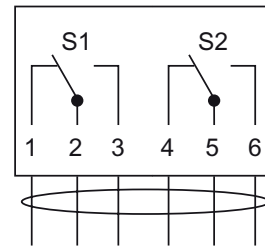

(2) Auxiliary switches, SPDT, 24 VAC, 5 (2.5) A, w/ adjustable cam for any position setting

GA-T135-024

On/Off control

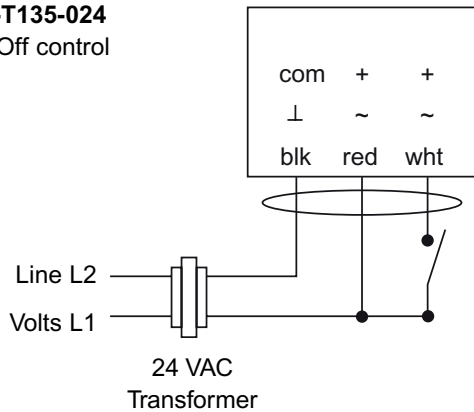

Option P1

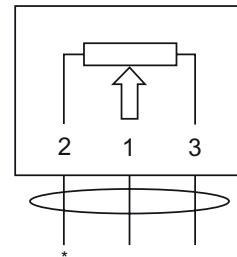

(1) Feedback pot, 1 k Ω ,
* = 0 Ω at 0° angle of rotation

Multiple actuators (maximum quantities)	GA-T135-024 Tri-state or On/Off
Stacking (torque is additive)	4
Parallel connection	20

L/R selector (built-in actuator cover)

Select	Angle of rotation	
R	CW/0-90°	w/red connect
R	CCW/90-0°	w/white connect
L	CW/0-90°	w/white connect
L	CCW/90-0°	w/red connect

7 Parallel control of two or more actuators

Notes:

- Provide overload protection and disconnect as required.
- Actuator and controller must have separate transformers.
- Set reversing switch L/R as required.

GA-T135-024

Tri-state
(3-point floating) control

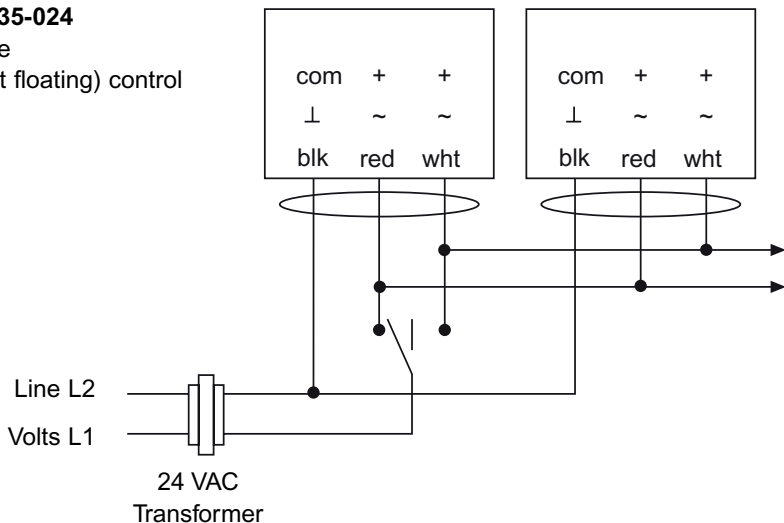

Attention:

- Observe polarity on secondary of transformers.
- Connect all actuator blk-wires to line of transformer and all red- and wht-wires of parallel controlled actuators together via switch to the other leg of the transformer.

Before starting the operation, all electrical and mechanical functions have to be checked!

GA-T135-024

On/Off control

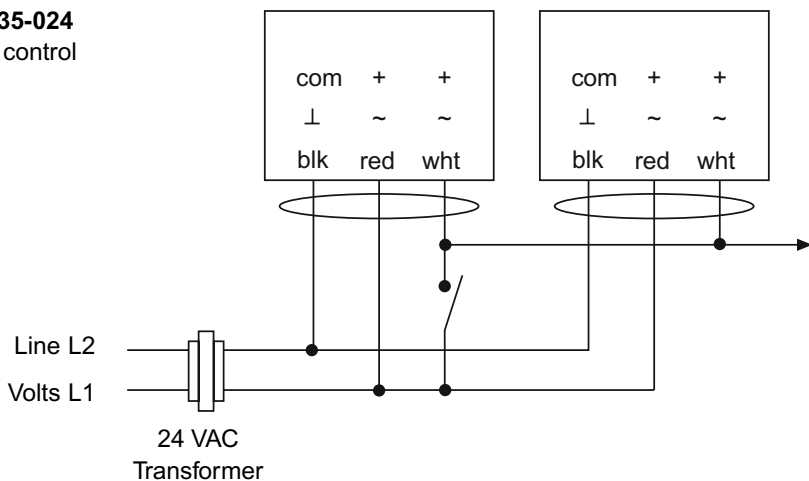

Attention:

- Observe polarity on secondary of transformers.
- Connect all actuator blk-wires to line of transformer and all red-wire to the other leg of the transformer.
- White lines of parallel controlled actuators are connected together via switch to the volts line.

Before starting the operation, all electrical and mechanical functions have to be checked!

8 Dimensions

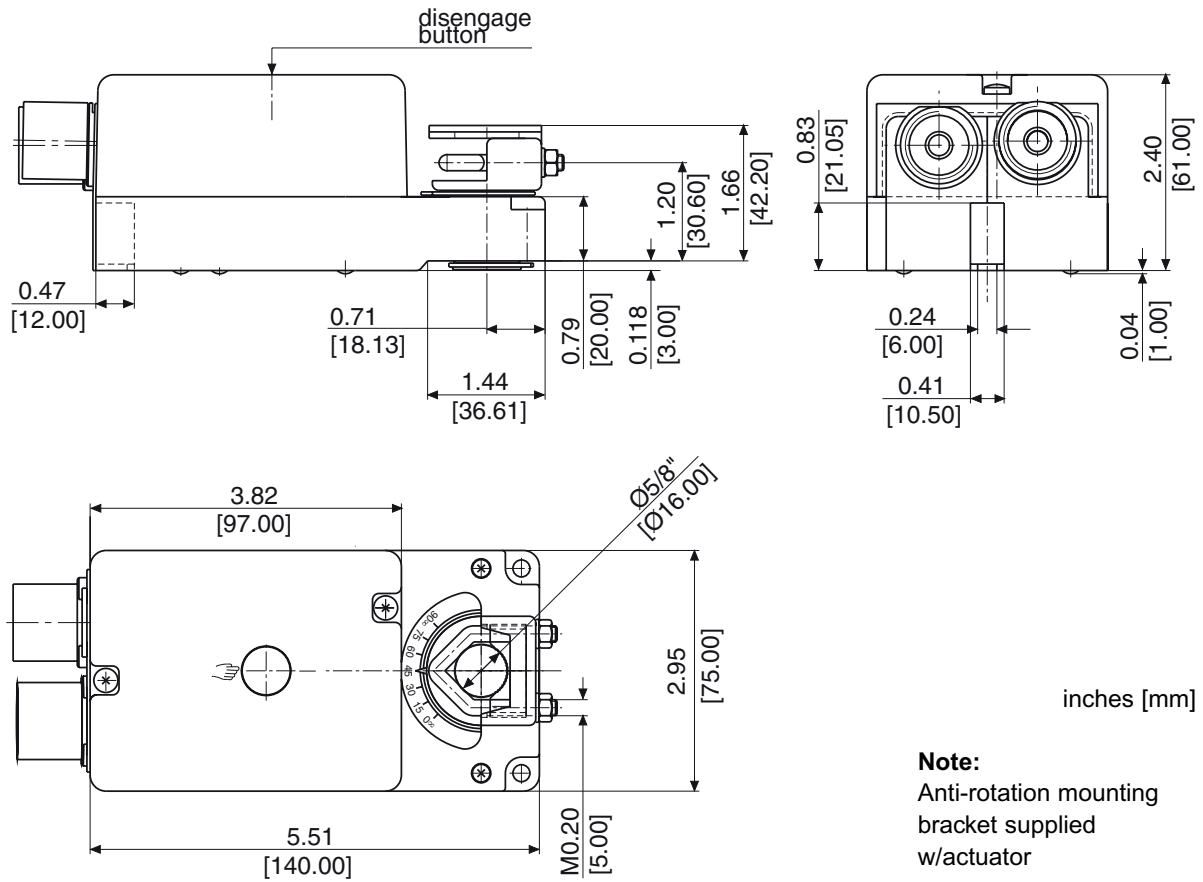

9 Ordering information

GA-T135-024	Standard
GA-T135-024-S2	w/(2) Aux. switches
GA-T135-024-P1	w/(1) 1 kΩ Pot

10 Specifications

Control

Input signal Tri-state (3-pt. floating) or On/Off, 24 VAC/DC

Electrical

Power supply 24 VAC/VDC ± 20%, 50/60 Hz
 Over voltage Up to 40 V, max. 5 sec.
 Power consumption 4.5 W (8.0 VA)

Performance

Torque 135 in-lb (15 Nm)
 Damper size Up to 34 sq. ft. (3 m²)
 Angle of rotation 0-95°/95-0°, selectable
 · CCW(L) and CW(R) L/R selector, built-in actuator cover
 Rotation time 40 to 80 sec/0-90°
 Power failure Stays in last position of operation

Position indicator 0-90° and adj. visual indicator

Synchronization ± 1%
 Overload protection Electronic throughout rotation

Manual override Built-in disengage button
 Motor type DC motor
 Noise level Max. 40 dB(A)

Environmental

Permissible ambient
 · working temperature -22°F to 122°F (-30°C to 50°C)
 · storage temperature -40°F to 176°F (-40°C to 80°C)
 · humidity 5-95% RH, non-condensing

Physical

Enclosure
 · cover ABS, UL 94-5V
 · base PA 6.6
 · color Grey and black
 · protection NEMA 2
 Mounting position Any position
 Anti-rotation bracket Included w/actuator
 Stacking/paralleling Refer to table "Multiple Actuators"

Clamp connection to
 · round shaft Ø 5/16" to 5/8" (8 to 16 mm)
 · square shaft □ 5/16" to 15/32" (8 to 12 mm)

Wire connection 3 ft. (0.9 m) appliance cable, color coded

· option, on request Plenum rated cable
 Wire size 18 AWG (0.75 mm²)

Conduit connector 1/2", built-in
 Dimensions 5.51 x 2.95 x 2.28 in. (140 x 75 x 58 mm)

Weight 3.3 lbs. (1.5 kg)

Manufacturing ISO 9001 certified

Listings/Approvals CE

UL and CSA

Warranty Five-year material and workmanship (Two-year standard, three-year conditional)

Options

· S2 (2) Aux. switches built-in SPDT 24 VAC, 5 (2.5) A, adj. at any position, incl. 3 ft. (0.9 m) appliance cable, number coded, and 1/2" conduit connector
 · P1 (1) Feedback pot 1 kΩ pot, incl. 3 ft. (0.9 m) appliance cable, number coded, and 1/2" conduit connector