

GA-T70-024

Direct coupled, non-spring return actuators, 70 in-lb

User Manual

July, 2003

page

1 Application4

2 Safety remarks4

3 Installation.....4

4 Adjustment of the angle of rotation5

5 Adjustment of the rotation direction and of the auxiliary switch.....5

6 Wiring configuration7

7 Parallel control of two or more actuators8

8 Dimensions9

9 Ordering information.....9

10 Specifications10

Direct coupled, non-spring return actuators, 70 in-lb

1 Application

Actuators to be easily installed by direct shaft mounting on air dampers, shutters and butterfly valves in ventilation and air conditioning systems. Can be controlled by any compatible electric or electronic analog controller DDC/PLC control or automation system. The actuators should be mounted indoors in a dry environment, relatively free from corrosive fumes.

2 Safety remarks

The actuators are not suitable for use in explosive atmospheric applications!

All service to the actuators (mounting, electrical connection, retrofitting and repair) must be carried out with the power supply disconnected. The electrical connection must be done by a trained and competent person considering the wiring diagrams, local and national regulations. Use copper twisted conductors only. Provide disconnect and overload protection if necessary.

This actuator may only be operated by 24 VAC/VDC!

The transformer **must** be sized according to technical data of the actuator (see section 10).

Always read the controller installation instructions before making any connection!

3 Installation

Direct mounting with V-bolt clamp to the damper shaft (diagr. 1) and fixing with enclosed anti-rotation mounting bracket (diagr. 2).

Shaft: $\varnothing 5/16"$ to $5/8"$ ($\varnothing 8 - 16$ mm)

$\square 5/16"$ to $15/32"$ ($\square 8 - 12$ mm)

- Turn the damper until the blades are closed
- Disengage the gears by pressing the red button and rotate the clamp until the switching position indication shows 90°
- Tighten the nuts on the clamp (4 - 6 ft-lb)

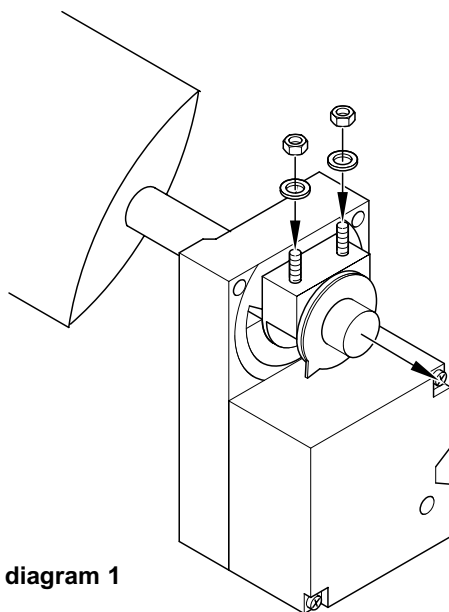

diagram 1

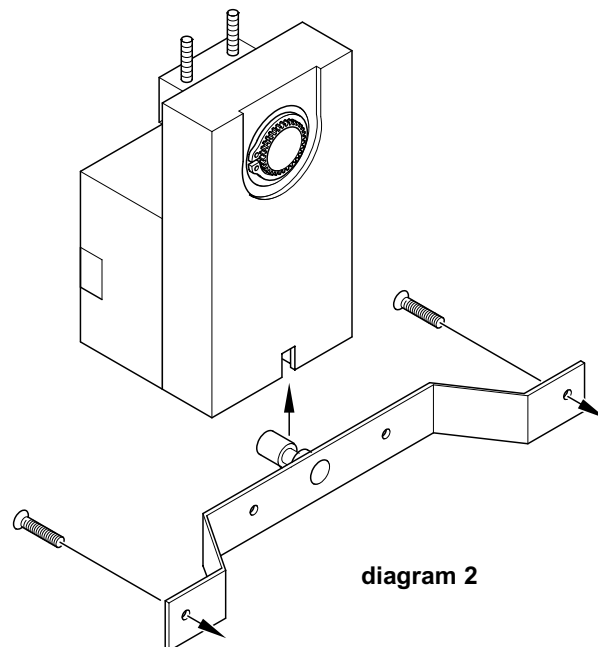
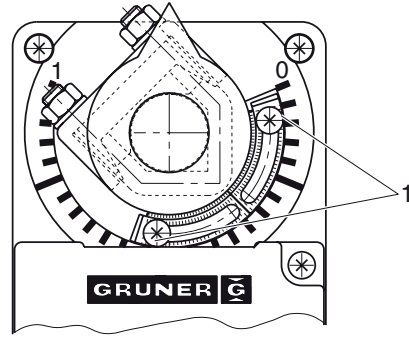

diagram 2

4 Adjustment of the angle of rotation

Both end stops are adjusted to 0° and 90°. For smaller rotation angles, loosen the screws (1) at the metal end stop, adjust the end stops as required, and fasten the screws again.



5 Adjustment of the rotation direction and of the auxiliary switch

Rotation direction

The actuator is adjusted to clockwise direction by the factory --> "R". To change the direction of rotation, turn the adjustment knob (2) to "L".

Types with terminals have no knob. In this case change (+) and (-).

Auxiliary switch

The scale at the adjustment knob (3) corresponds to a percentage graduation, related to 0° to 90°.

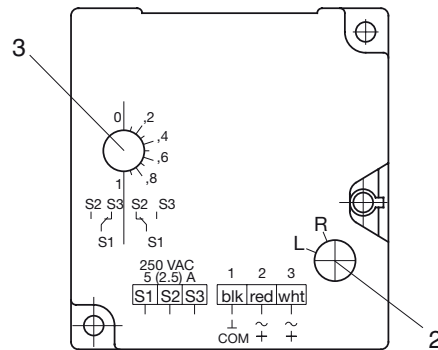

Drive is placed at 0° on the end stop

Turn the adjustment knob from 0 to the right until the tip indicates the required switching position.

For example, 2 = 20% of the angle of rotation. Drive turns to the right and the switch switches at 20% of the angle of rotation (operating position S1-S3).

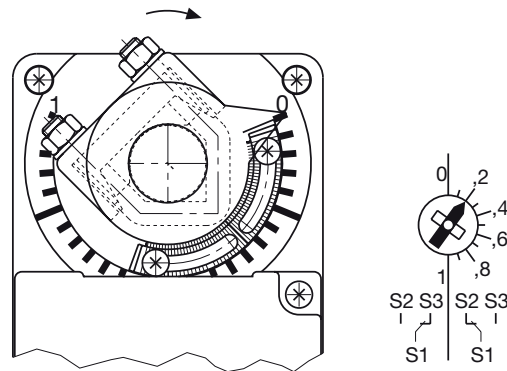

Drive at operating position

Press the override button and turn the drive to the required operating position, for example, 20% of the angle of rotation. Turn the adjustment knob to 0 and pass with the tip slightly. As a result, 20% of the angle of rotation is adjusted (operating position S1-S3).

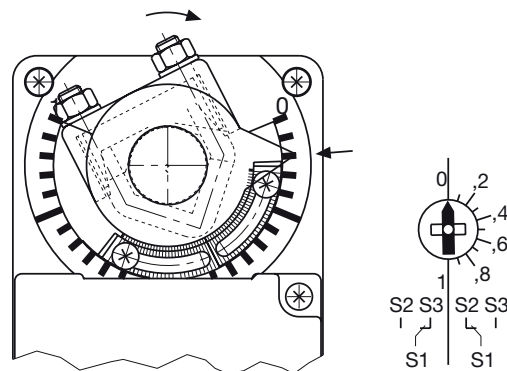

Drive is placed at "1" on the end stop

Turn the adjustment knob from 1 to the left until the tip indicates the required switching position. For example, 8 = 20% of the angle of rotation. Drive turns to the left and the switch switches at 20% of the angle of rotation (operating position S1-S3).

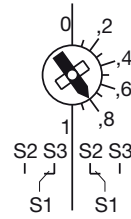
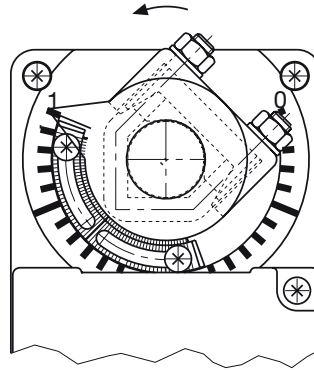

Drive at operating position

Press the override button and turn the drive in the required operating position, for example, 20% of the angle of rotation. Turn the adjustment knob to 1 and pass with the tip slightly. As a result, 20% of the angle of rotation is adjusted (operating position S1-S3).

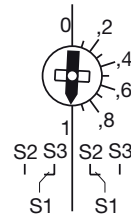
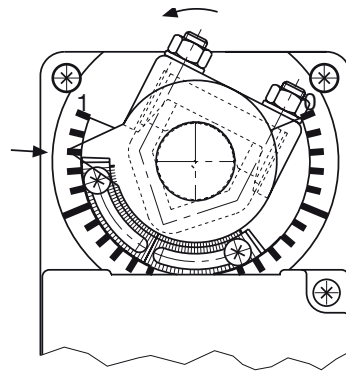

6 Wiring configuration

Notes:

- Actuators are provided with color coded wires. Wires for optional switches and feedback pot are number coded.
- Observe polarity on secondary of transformers. Incorrect polarity can cause controller damage or operation error.
- Provide overload protection for line voltage and disconnect as required.

GA-T70-024

Tri-state
(3-point floating) control

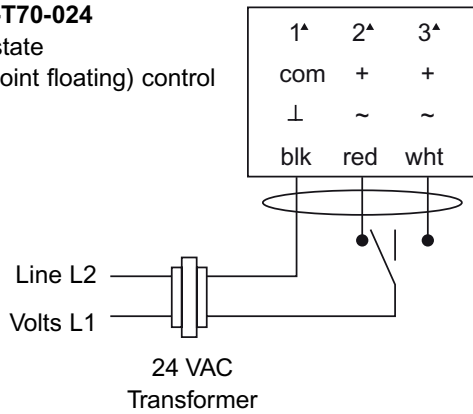

Option S1

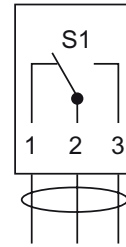

(1) Auxiliary switch, SPDT, 24 VAC, 5 (2.5) A, w/ adjustable cam for any position setting

GA-T70-024

On/Off control

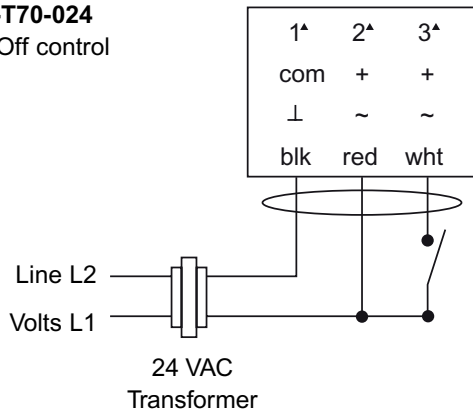

Option P1

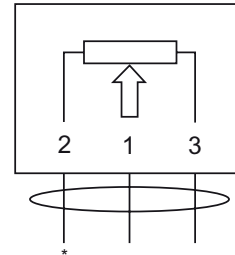

(1) Feedback pot, 1 k Ω ,
* = 0 Ω at 0° angle of rotation

▲ Terminal version wiring connection:

1 = com 2 = + (CW/0-90°) 3 = + (CCW/90-0°)

Multiple actuators (maximum quantities)	GA-T70-024 Tri-state or On/Off
Stacking (torque is additive)	4
Parallel connection	20

L/R selector (built-in actuator cover)

Select	Angle of rotation	
R	CW/0-90°	w/red connect
R	CCW/90-0°	w/white connect
L	CW/0-90°	w/white connect
L	CCW/90-0°	w/red connect

7 Parallel control of two or more actuators

Notes:

- Provide overload protection and disconnect as required.
- Actuator and controller must have separate transformers.
- Set reversing switch L/R as required.

GA-T70-024

Tri-state
(3-point floating) control

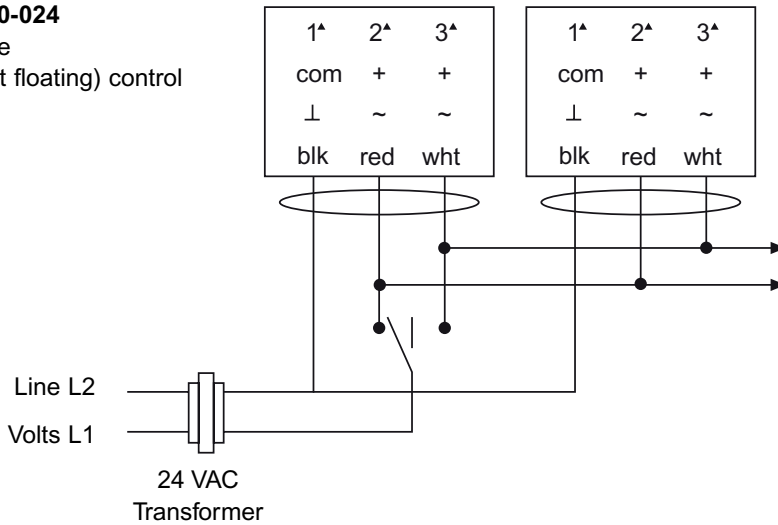

Attention:

- Observe polarity on secondary of transformers.
- Connect all actuator blk-wires (1) to line of transformer and all red (2)- and wht (3)-wires of parallel controlled actuators together via switch to the other leg of the transformer.

Before starting the operation, all electrical and mechanical functions have to be checked!

GA-T70-024

On/Off control

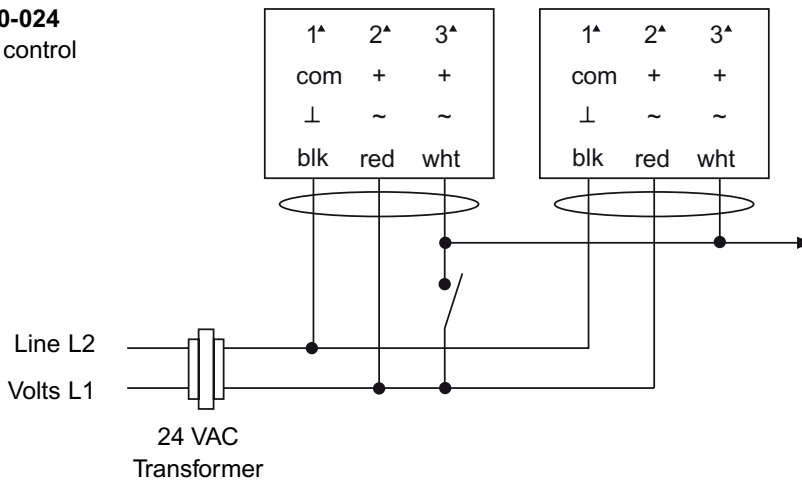

Attention:

- Observe polarity on secondary of transformers.
- Connect all actuator blk (1)-wires to line of transformer and all red (2)-wire to the other leg of the transformer.
- White (3) lines of parallel controlled actuators are connected together via switch to the volts line.

Before starting the operation, all electrical and mechanical functions have to be checked!

8 Dimensions

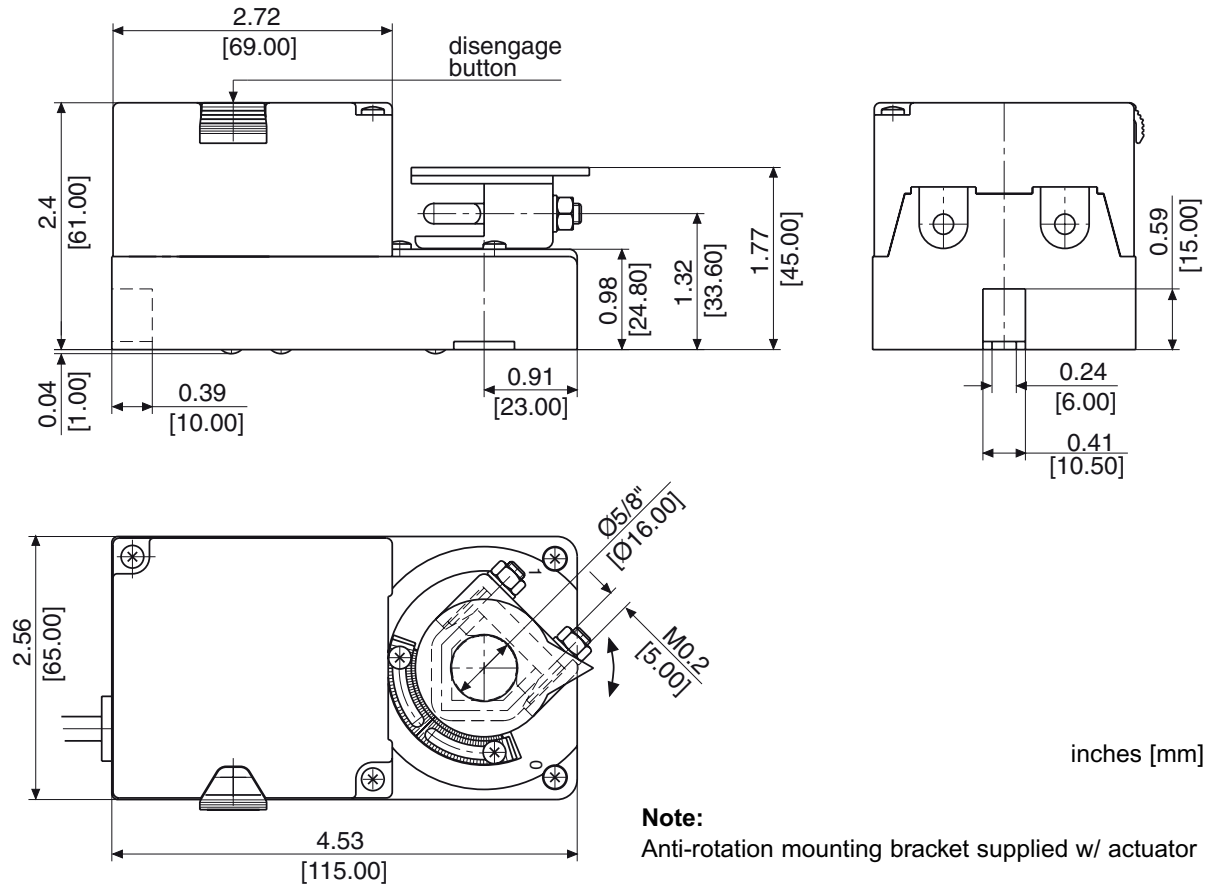

9 Ordering information

- GA-T70-024** w/ Plenum rated cable
- GA-T70-024-S1** w/ Plenum rated cable, and (1) aux. switch
- GA-T70-024-P1** w/ Plenum rated cable, and (1) 1 kΩ Pot
- GA-T70-024T** w/ Terminal block
- GA-T70-024T-P1** w/ Terminal block, and (1) 1 kΩ Pot

Note:
Terminal version actuator comes without L/R selector and adj. visual position indicator.

10 Specifications

Control

Input signal Tri-state (3-pt. floating) or On/Off, 24 VAC/DC

Electrical

Power supply 24 VAC/VDC ± 20%, 50/60 Hz

Over voltage Up to 40 V, max. 5 sec.

Power consumption 2.0 W (3.0 VA)

Performance

Torque 70 in-lb (8 Nm)

Damper size Up to 18 sq. ft. (1.6 m²)

Angle of rotation 0-95°/95-0°, selectable, adj. angle with integral stops

· CCW(L) and CW(R) L/R selector, built-in actuator cover (Terminal version is w/o L/R selector)

Rotation time 60 to 120 sec/0-90°

Power failure Stays in last position of operation

Position indicator 0-10 divisions and adj. visual indicator (Terminal version is w/o visual indicator)

Synchronization ± 1%

Overload protection Electronic throughout rotation

Manual override Built-in disengage button

Motor type DC motor

Noise level Max. 35 dB(A)

Environmental

Permissible ambient

· working temperature -22°F to 122°F (-30°C to 50°C)

· storage temperature -40°F to 176°F (-40°C to 80°C)

· humidity 5-95% RH, non-condensing

Physical

Enclosure

· cover ABS, UL 94-5V

· base PA 6.6

· color Gray and black

· protection NEMA 2, NEMA 1 for Terminal version

Mounting position Any position

Anti-rotation bracket Included w/actuator

Stacking/paralleling Refer to table "Multiple Actuators"

Clamp connection to

· round shaft Ø 5/16" to 5/8" (8 to 16 mm)

· square shaft □ 5/16" to 15/32" (8 to 12 mm)

Wire connection 3 ft. (0.9 m) cable, color coded, plenum rated

Wire size 18 AWG (0.75 mm²)

Terminal version · wire connection Terminal block, outside of cover, screw type for lead wire, min. 26 AWG (0.14 mm²) max. 14 AWG (2.5 mm²)

Dimensions 4.53 x 2.56 x 2.40 in. (115 x 65 x 61 mm)

Weight 1.2 lbs. (0.53 kg)

Manufacturing Listings/Approvals ISO 9001 certified CE

Warranty UL and CSA Five-year material and workmanship (Two-year standard, three-year conditional)

Options

· S1 (1) Aux. switch built-in SPDT 24 VAC, 5 (2.5) A, adj. at any position, incl. 3 ft. (0.9 m) cable, number coded, plenum rated, or terminal block

· P1 (1) Feedback pot 1 kΩ pot, incl. 3 ft. (0.9 m) cable, number coded, plenum rated, or terminal block