

## Installation and Operation Instructions

### I/CO<sub>2</sub>, I/CO<sub>2</sub>-VDC, I/CO<sub>2</sub>-T

#### READ THESE INSTRUCTIONS BEFORE YOU BEGIN INSTALLATION

##### ■LOCATION

The I/CO<sub>2</sub> transmitter is designed to mount over a standard single gang electrical or junction box approximately 4 to 6' above the floor. Make sure that the transmitter is mounted at least 3 feet from any corner and 2 feet from an open doorway. Do not mount the sensor close to a window, on an outside wall, next to any door that leads directly outside, or over heat sources. Also, make sure that the sensors are not exposed to direct occupant breathing such as near vending machines, water fountains, bubblers, or coffee machines.

##### ■MOUNTING

**Room Mount:** First remove the mounting plate from the sensor and mount it to the wall or junction box using (2) 6/32 x 1" machine screws and/or drywall anchors. If the CO<sub>2</sub> transmitter will be mounted to a drywall wall, use the mounting plate as a template to mark both the mounting and wiring holes. Now securely mount the mounting plate to the wall or junction box and make all of the necessary connections as shown in **Figure #1**. At this time the CO<sub>2</sub> controller can be mounted on the base by aligning the top clips and then securing to the bottom clips. A "snap" sound will indicate that the sensor is secure and the unit will now have power. When powered, the LED on the front of the unit will blink for approximately 6 seconds and then remain on. Please note that the I/CO<sub>2</sub>-T and the I/CO<sub>2</sub>-VDC don't have the RED LED indicator that lights upon initial power up. The warm up time will last for approximately 2 minutes. Now finish the installation by sliding the cover over the menu keys and secure with the supplied screw.

**Duct Mount:** The I/CO<sub>2</sub> duct mount version should be mounted in the return air duct in a location where the CO<sub>2</sub> sensor and the Pitot tube can be mounted as close together as possible. The duct should have a minimum flow rate of at least 600 and no more than 4,000 FPM. Now remove the mounting plate from the sensor and mount it to the wall or junction box using (2) 6/32 x 1" machine screws and/or drywall anchors. If the CO<sub>2</sub> transmitter will be mounted to a drywall wall, use the mounting plate as a template to mark both the mounting and wiring holes. Now securely mount the mounting plate to the wall or junction box and make all of the necessary connections as shown in **Figure #1**. At this time the CO<sub>2</sub> controller can be mounted on the base by aligning the top clips and then securing to the bottom clips. A "snap" sound will indicate that the sensor is secure and the unit will now have power. When powered, the LED on the front of the unit will blink for approximately 6 seconds and then remain on. Please note that the I/CO<sub>2</sub>-T and the I/CO<sub>2</sub>-VDC don't have the RED LED indicator that lights upon initial power up. The warm up time will last for approximately 2 minutes. Now finish the installation by sliding the cover over the menu keys and secure with the supplied screw.

**Pitot Tube Installation:** To mount the Pitot tube, drill (1) 7/8" hole through the duct. Now insert the Pitot tube and mark the (2) remaining holes for the mounting screws and punch or drill the (2) marked holes. Re-insert the Pitot tube into the duct making sure to note the direction of the airflow in the duct and the arrow direction on the Pitot tube itself. Now secure the Pitot tube to the duct with sheet metal screws or rivets. **Note: To ensure an airtight seal, assure the mounting surface of the duct is clear of dirt or other obstructions.**

**Tubing Installation:** On the top of the I/CO<sub>2</sub> Duct sensors, unscrew the protective covers on the Pitot tube connectors. Verify the length of the tubing before attaching to the sensor. The tubing should connect without any stretching or pulling. If the length is long enough to create a loop or bind in the tubing, it should be shortened. To shorten the tubing, remove the Pitot tube connectors and cut the tubing to length. Replace the Pitot tube connectors by using a twisting or screwing motion. Verify that all of the connectors are secure. **Note: If the tubing length has been shortened, be sure the in-line filter is replaced on the Pitot tube connector marked with an "H"**. Complete the installation by screwing the tube connectors to the input ports on the sensor. Note that the input ports on the sensor are the same so the connectors on the tubing can be attached to either input port, since it will not affect the overall performance of the sensor.

■ **Wiring Diagrams**

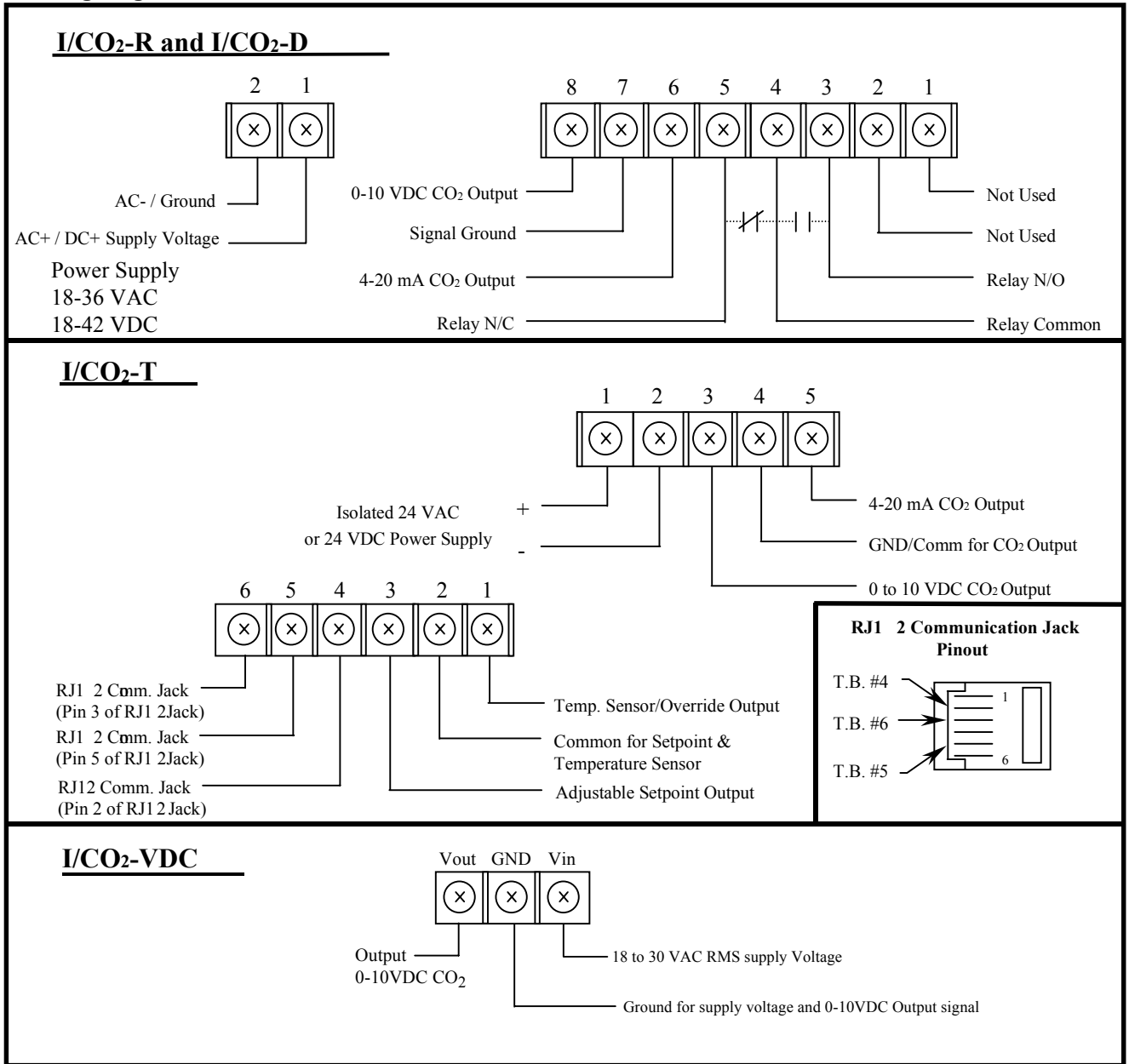

**Figure #1**

■ **Configuring the Sensor**

**Adjustable Sensor Settings:**

The I/CO<sub>2</sub> series uses a 16 Bit microprocessor that allows the design to incorporate the number of adjustable features at no additional cost. These adjustments can be made using the keypad display units or by the PC based UIP program that communicates to the sensor via a custom RS232 interface cable.

**Factory Settings:**

The standard factory settings are the typical settings used when a CO<sub>2</sub> sensor is connected to a building control system. If the installation is somewhat unique or specialized, the user can customize certain characteristics of the sensor. For example, non-factory settings may be applicable when the sensor is being connected to equipment that has a fixed input range (e.g. actuators used with economizer control systems).

Outlined on the top of the next page are the adjustable parameters of the sensor and the factory setting. In addition to these adjustable features, the programming interface allows for a fast and simple adjustment of sensor calibration. **See Figure #2**

<b>Adjustment</b>	<b>Range</b>	<b>Factory Setting</b>
Altitude Above Sea Level	0 to 10,000 Ft	0 Ft
ABC Logic™	On/Off	On
Select Standard Setting	1 to 9	1
Customize Setting		
PPM Range	0 to 10,000	0 to 2,000
Output Range	4-20 mA/0-10 VDC	4-20 mA/0-10 VDC
Proportional/Exponential Output	Select One	Proportional
Relay Setpoint	0 to 10,000 PPM	1,000 PPM
Relay Hysteresis	0 to 10,000 PPM	50 PPM

**Figure #2**

**■ When to Use Programming Features**

**Altitude:**

All I/CO<sub>2</sub> series products are calibrated at sea level. As altitude increases, the density of the air around us slightly decreases. This natural phenomenon affects the accuracy of all gases and introduces an error of approximately -3% of the reading per 1000 ft of elevation. Much of the urbanized world is at an elevation of less than 1000 ft meaning that the altitude has very little effect on the reading and no adjustment is necessary. However, users in locations significantly higher than sea level such as Denver, Colorado may want to consider adjusting for elevation based on altitude to have the most accurate reading. The altitude setting can be adjusted on the unit in 500 ft increments.

**ABC Logic™ Self-Calibration System:**

All I/CO<sub>2</sub> series commercial sensors are factory set with the ABC Logic™ (Automatic Background Calibration) self calibration feature *ON*. This feature allows the sensor to continually recalibrate itself when the indoor concentrations drop to outside levels while the building is unoccupied. Generally, a building must be regularly unoccupied (with the exception to cleaning and maintenance staff) for 4 hours or more for this self-calibration system to operate properly. Under these conditions, ABC Logic™ should maintain sensor calibration over the lifetime of the sensor. The ABC Logic™ should be turned *OFF* where a building is continuously occupied for 24 hours per day, or where there could be significant sources of non-occupant related CO<sub>2</sub> such as greenhouses, breweries, and other industrial and food processing applications.

**Pre-Programmed Settings:**

In addition to the factory setting for the I/CO<sub>2</sub> series sensors, there are (9) standard settings that can easily be selected using the keypad (display units only) or the PC based UIP program. The chart below describes each of the settings. The definitions for some of the terms used in the chart are described in more detail as part of the custom settings section to follow.

**Settings 1, 2, and 3** are applicable for automated or computerized building control systems.

**Settings 4, 5, 6, and 7** are specifically designed for operation with economizer controls and actuators where a 0-10 VDC signal will provide 0 to 100% outside air modulation. These control settings provide different modulation ranges, depending on the target CFM-per-person ventilation rate desired. As described below the exponential setting is best used in applications that have large volumes of air and people such as auditoriums, gyms, and large conference areas.

**Setting 8** is intended for use in applications related to occupational health and safety where users may want to measure concentrations in relation to the 5000 PPM 8 hour exposure levels established by OSHA (Occupational Safety and Health Administration.)

**Setting 9** is intended for use in parking garages where CO<sub>2</sub> can be used as an indicator of the presence of combustion fumes. As part of most types of combustion, CO<sub>2</sub> is generated at a rate that is 50 times or more of other more harmful contaminants. This is particularly the case with the extensive use of catalytic converters that tend to remove most of the carbon monoxide from vehicle exhaust. The 700 PPM setting should maintain levels of other exhaust contaminants well below levels of concern.

**Custom Settings:**

In addition to the (9) standard settings programmed into the I/CO<sub>2</sub> series sensors, users can also custom program the sensor for their own application. Outlined below is a brief description of each of the adjustable custom settings: (See **Figure #3**)

Setting No.	Type of Equipment	Type of Output	Ventilation Rate (CFM/person)	Analog Output	CO2 Control Range (PPM)	Optional Relay Setpoint (PPM)	Relay Hysteresis (PPM)
1	Interface w/ Standard Building Control System	Proportional	Any	0-10V 4-20 mA	0-2000	1000	50
2	Interface w/ Standard Building Control System	Proportional	Any	2-10V 7-20 mA	0-2000	1000	50
3	Interface w/ Standard Building Control System	Exponential	Any	0-10V 4-20 mA	0-2000	1100	50
4	Economizer (HVAC)	Proportional	15	0-10V 4-20 mA	0-1100	1100	50
5	Economizer (HVAC)	Proportional	20	0-10V 4-20 mA	0-900	900	50
6	Economizer (HVAC)	Exponential	15	0-10V 4-20 mA	0-1100	1100	50
7	Economizer (HVAC)	Exponential	20	0-10V 4-20 mA	0-900	900	50
8	Health and Safety	Proportional	NA	0-10V 4-20 mA	0-9999	5000	500
9	Parking/Air Intakes/ Loading Docks	Proportional	NA	0-10V 4-20 mA	0-2000	700	50

**Figure #3 - Standard Settings Available via the keypad (Display units only) or PC based UIP Interface (All Units).**

*Control Range:* The range that will correspond to the analog signal output range. The range consists of a low level and a high level in PPM. Setting this range does not limit the actual measurement or display range.

*Analog Output Range:* Can be expressed in V or mA. This range will correspond to the range of CO<sub>2</sub> concentrations established in the measurement range. On the I/CO<sub>2</sub> series sensors, a V and mA output is selected based on the wiring terminals. It is possible to simultaneously connect to both the V and mA outputs.

*Proportional or Exponential Control:* Proportional (linear) control increases the signal output in proportion to the increase in CO<sub>2</sub> concentrations for the measurement range and the analog output range selected. Exponential control provides an output function that is exponential over the selected range of the sensor. The effect of the exponential output is to initially introduce more ventilation to the space as concentrations are at the lower level of the control range. The exponential output is particularly useful for areas of potential high occupancy and high air volume where significant time may be required for CO<sub>2</sub> levels to build up. Potential applications include arenas, gyms, auditoriums, and large conference areas. Examples of both types of outputs are provided below. (See Figure #4)

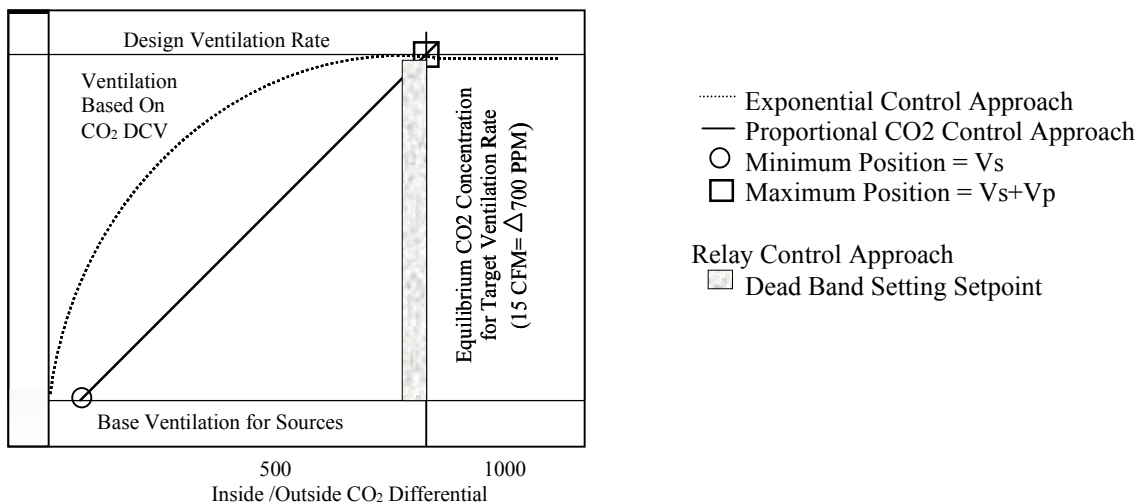

**Figure #4: Proportional and Exponential Control**

*Relay Setpoint:* Establishes the level at which the on-board relay will activate. The relay is a *Double Pole Single Throw (DPST) relay* that allows the user to operate the relay *Normally-Open (N/O)* or *Normally-Closed (N/C)* based on the selection of wiring terminals connected on the sub-base.

*Relay Hysteresis (Dead Band):* Is the point at which the relay will deactivate or de-energize. It is entered as a PPM value below the setpoint. A sensor with a relay setting of 1000 and a hysteresis of 50 would activate at 1000 PPM and deactivate at 950 PPM.

**■ Adjusting the Sensor with the UIP Program**

The UIP (Model 2072) is a User Interface Program designed to work with the I/CO<sub>2</sub> series ventilation controllers. The program offers a windows interface which enables the user to make quick, easy adjustments to the output, elevation, relay setpoint, hysteresis, and more. It can also be used, along with the calibration gases, to calibrate the sensor. This program is especially useful for the units without a display.

All of the I/CO<sub>2</sub> sensors that have a display and pushbuttons will allow you to review and change the sensors operating parameters. The UIP 2072 program allows you to make these same adjustments to all I/CO<sub>2</sub> sensors regardless of whether they have a display or pushbuttons. The UIP accessory package comes with the program and cables for connecting the sensor to a laptop computer that has a serial communications port. Simply plug the computer cable into the sensor's RJ45 connector and the program is ready to use.

**■ Adjusting the Sensor with On-Board Keypad**

(Display Units Only)

**Button Functions:**

- [CLEAR]            -Resets Menu  
                          -Returns to Normal Menu
- [MODE]            -Toggles to Next Menu Item
- [ENTER]           -Press to Lock Menu
- [UP/DOWN]        -Increase/Decrease Selection Value

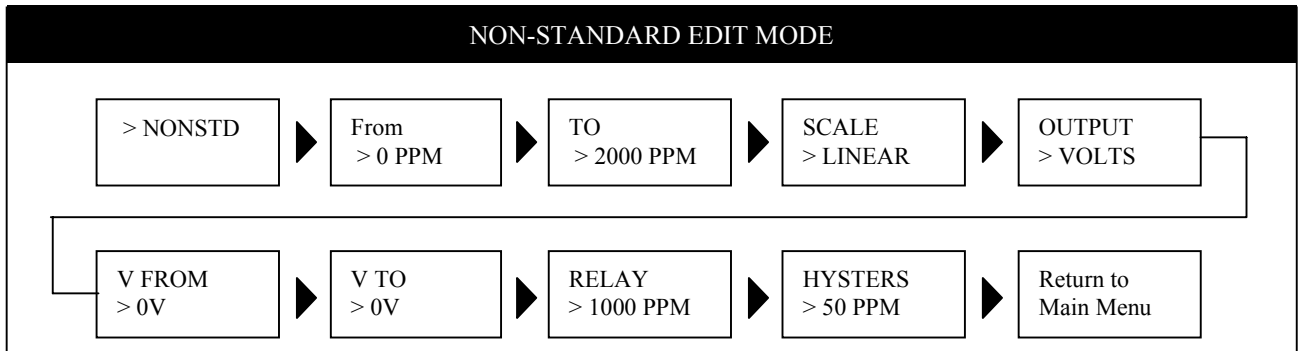

Flowchart Showing Sequence of Non-Standard Edit Mode

**Altitude Correction and ABC Logic™ (On/Off):**

1. After a 2 minute warm-up period, press [CLEAR] + [MODE] and hold at least 5 seconds until the sensor enters the edit mode.
2. The first menu will be altitude correction. The adjustments will Increase/Decrease in 500 ft increments. To do this use the [UP/DOWN] rocker button to adjust to the proper altitude.
3. Press [ENTER] to lock in value and press [MODE] to proceed to ABC Logic™.
4. Use the [UP/DOWN] Rocker button to switch to ON or OFF.
5. Press [ENTER] to lock in value then press [MODE] to proceed to Normal Mode.

Note: It is recommended that the ABC Logic™ feature be left ON for the best sensor operation.

**Selecting a Pre-Programmed Setting:**

The pre-programmed settings shown in Table 3 are factory set and cannot be changed. These settings can be selected from the Standard Settings (STDSET) menu. The altitude and ABC Logic™ features can be changed without entering the Standard Settings (STDSET) menu.

1. After 2 minute warm-up period, press [CLEAR] + [MODE] and hold at least 5 seconds until the sensor edits the edit mode.
2. Press [MODE] 2 times. You will enter the STDSET menu.
3. Use the {UP/DOWN} Rocker Button to toggle to the NONSTD menu.
4. Press [MODE] to move through the variables. Use the [UP/DOWN] button to toggle to the desired setting.
5. Press [ENTER] to lock in the selection then press [MODE] to continue to the next variable.