

READ THESE INSTRUCTIONS BEFORE YOU BEGIN INSTALLATION

The I/LCD must be powered with either a 24 VAC or 8-35 VDC power source. The I/LCD uses a half-wave bridge rectifier to convert the AC Voltage to an usable DC voltage. This unit is available in many different configurations including Room w/Override, Room w/Setpoint, Room w/Setpoint and Override and may incorporate any of our resistive type temperature sensor.

■ TROUBLESHOOTING

Sensor reads 0 ohms or very low
 Sensor reads infinity or very high
 Erratic readings
 Display not working

Sensor or wires are shorted together
 Sensor or wires are open
 Bad wire connections – Condensation on Board
 Check the Power Connections

■ WIRING DIAGRAMS

● **Note: This designates all of the connections to the controller**

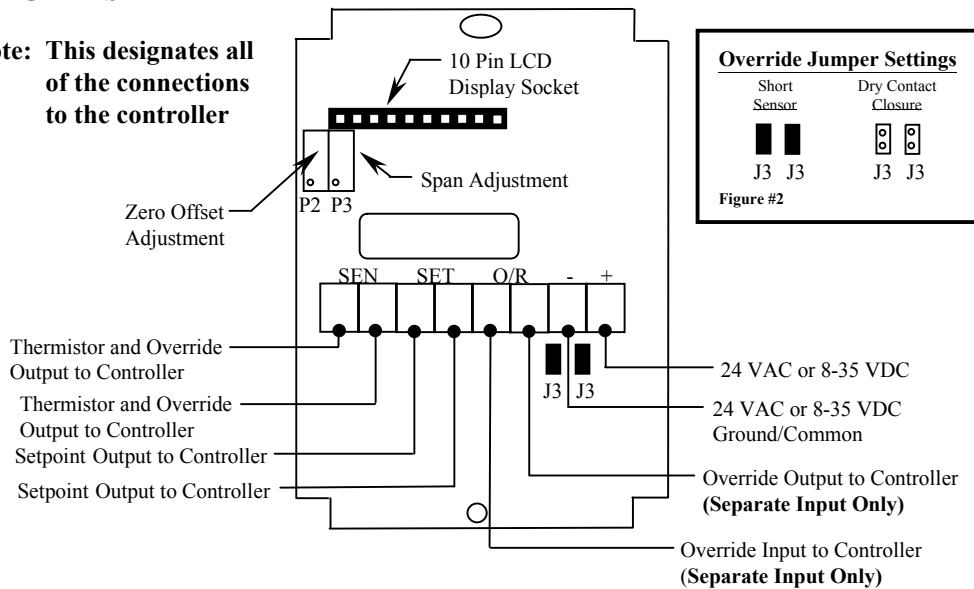

■ WIRING CONNECTIONS

A minimum of (4) wires to a maximum of (8) wires must be pulled for the LCD to work properly. The supply voltage to the display must be isolated from the sensor inputs to the controller. We recommend the use of 18 to 22 AWG twisted pair wires or shielded cable for all sensor installations.

■ MOUNTING INSTRUCTIONS

The I/LCD is shipped as a two-piece unit. The LCD Module must be unplugged from the 10 pin connector before the base of the sensor may be mounted to either the drywall or over a standard 2" x 4" Junction Box, using the mounting hardware provided. The LCD Module should then be gently inserted back into the 10 pin connector. The cover may now be placed onto the unit and tightened down using the (2) 1/16" Allen screws at the bottom of the housing.

■ TEMPERATURE DISPLAY ADJUSTMENTS

The temperature display may be adjusted by adjusting the ZERO or OFFSET Potentiometer (P2) as shown on the above diagram. Adjust (P2) until the LCD Display reading, matches your controllers temperature reading if necessary. All LCD Displays, are factory calibrated using an NIST Certified Glass thermometer.

■ OVERRIDE ADJUSTMENTS

If a Separate Input or Tenant Override (N/O Dry Contact Closure) is needed, remove both of the Jumpers or Shunts from J3, and connect both Override wires to the terminal block labeled O/R. (See Figure #2 Diagram)