

■ **WIRING DIAGRAM**

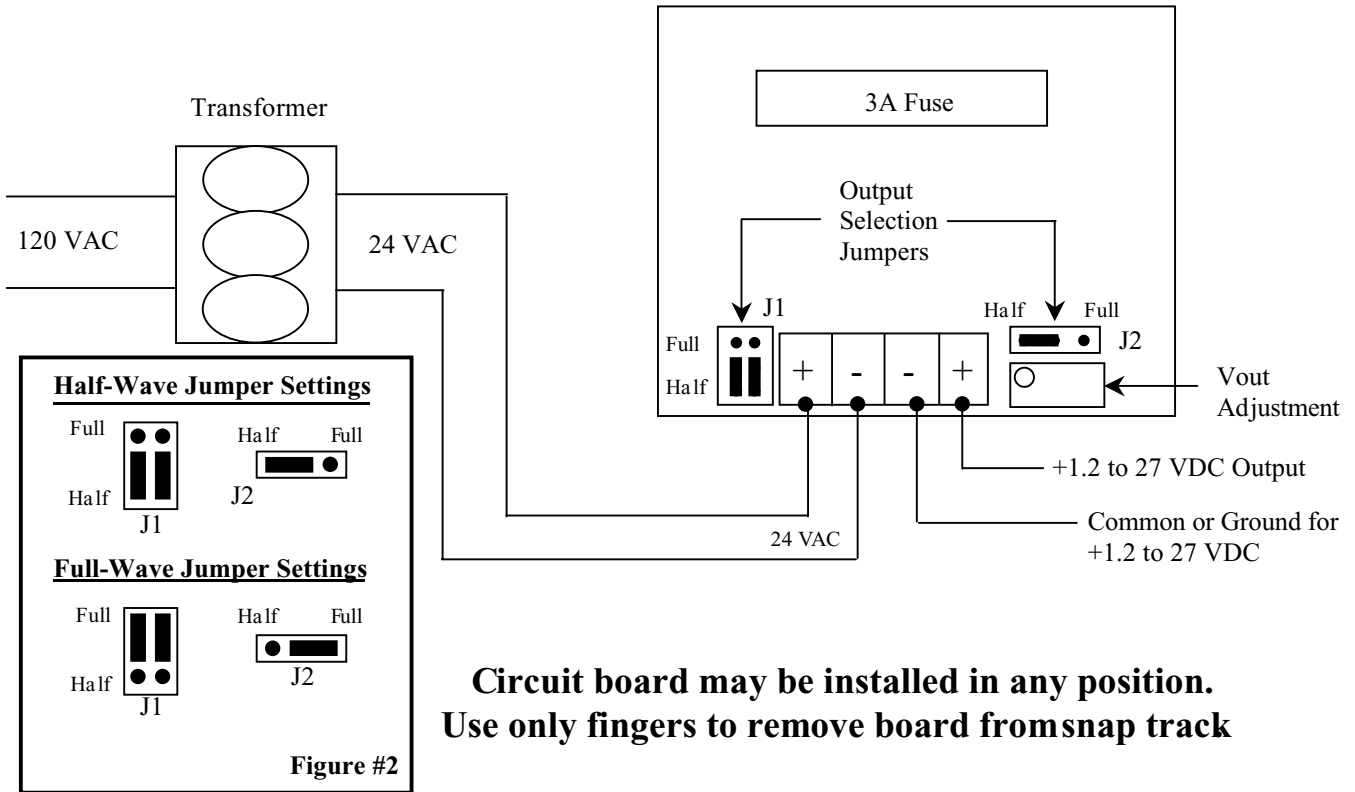

■ **Power Connections**

- 1) **Supply Voltage:** The input voltage to the I/PS1.5 should come from an isolated 24 VAC transformer or a 24 to 35 VDC power supply.
- 2) We recommends that the I/PS1.5 adjustable regulated power supply be used with a transformer, isolated from all other loads. If other field devices must be connected to the same transformer, they must all use the same common. If the transformer is shared with any devices that have coils, a spike suppressing device such as a diode or a MOV should be used.
- 3) A grounded DC (-) terminal and a grounded 24 VAC Input transformer will blow the unit's fuse in the **Full-Wave mode**.
- 4) In the **Full-Wave** mode, the 24 VAC transformer connections are **polarity sensitive**. Be sure to recheck the wires, before making final connections to the unit. **Failure to do so may result in damage to the unit or any other connected device.**

■ **Output Selection**

The I/PS1.5 comes with the option of selecting either a **Full-Wave** or **Half-Wave** output depending on your application needs. **All power supplies are shipped from the factory in Half-Wave mode.**

If you require a Full-Wave Power Supply, simply move the three output selection jumpers from the Half-Wave location to the Full-Wave location as shown in **Figure 2**. **Make sure that the power is turned off or disconnected when changing the jumpers.**