

READ THESE INSTRUCTIONS BEFORE YOU BEGIN INSTALLATION

■ WIRING

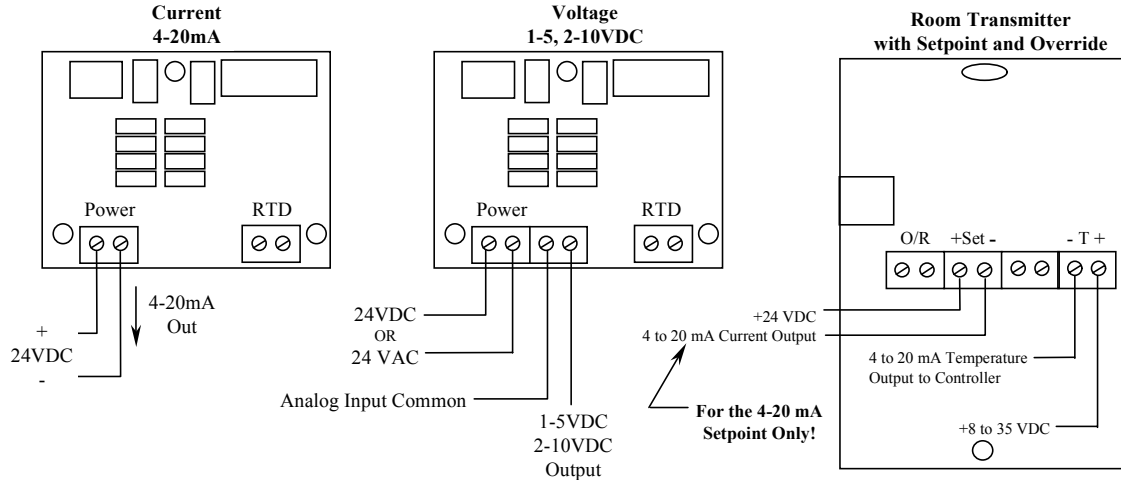

All I/TT and TTM temperature transmitters can be powered from either an unregulated or regulated +8 to 35VDC power supply. Several transmitters may be powered from the same supply as shown below. Each transmitter could draw 22mA. To determine the number of transmitters use the following formula:

$$N = I / 22mA$$

where: N = number of transmitters
 I = current available from power supply
 22mA = maximum current draw of transmitter
 e.g., If $I = 1.5A$ then:
 $N = 1.5/22mA$
 $N = 68$

Therefore a 1.5A power supply will safely power up to 68 transmitters.

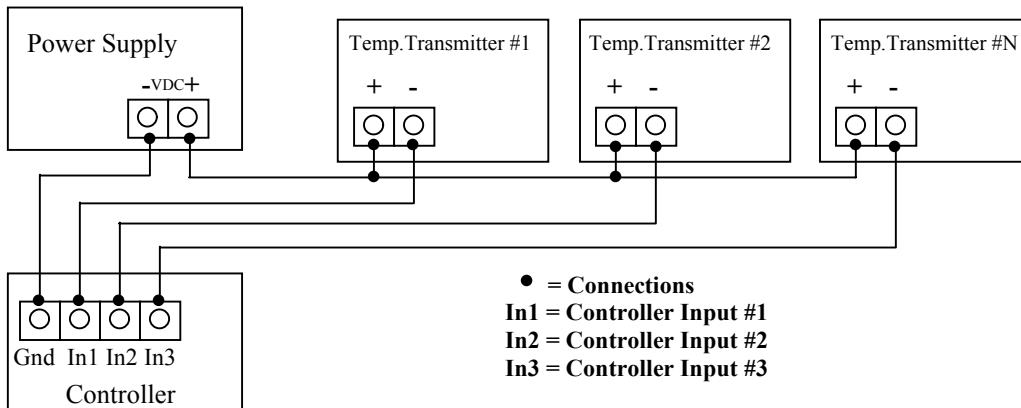

All I/TT, TTM, and I/TTU temperature transmitters are non-polarity sensitive. That means that either the positive and negative outputs of the power supply can be connected to either side of the power terminal block. The transmitters will also accept AC power only if specified when ordering. The output must be specified as a +1-5 or +2-10 for this option when ordering the transmitters.

■ROOM TEMPERATURE TRANSMITTERS

This unit is suitable for either drywall or junction box mounting. First, remove the cover of the housing and mount the base of the Room unit to the wall, using the (2) 6/32" x 1" screws that are provided. Once the base is mounted to the wall, make all of the proper connections and then place the cover back onto the unit. Now tighten the cover down, using the (2) 1/16" Allen screws located in the bottom of the housing. The Room transmitter is provided with a two pole terminal block for power and a two pole terminal block for the RTD, which allows for easy wiring of the unit.

■DUCT AND DUCT AVERAGING TEMPERATURE TRANSMITTERS

Duct Temperature Sensors - Drill a 3/8" hole in the duct and insert the probe through the hole until the foam pad is tight to the duct. Now insert (2) screws through the mounting holes in the flange and tighten until the unit is held firmly to the duct.

Duct Averaging Sensors - Drill a 3/8" hole in the duct and insert the averaging element through the hole until the foam pad is tight to the duct. Now insert (2) screws through the mounting holes in the flange and tighten until the unit is held firmly to the duct. The sensor should then be strung in a criss-cross pattern throughout the duct (see Figure #2) using the mounting clips provided, in a pattern that covers the greatest surface area of the duct, to insure that there is no stratification. When bending the copper tubing, be careful that you use a gradual bend and that you DO Not kink the copper tubing.

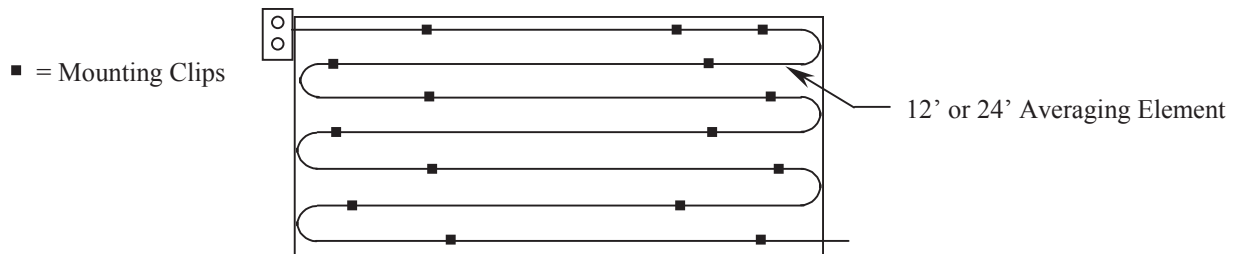

■FLUID IMMERSION TEMPERATURE TRANSMITTERS

The Fluid Immersion type transmitters are provided with a 2.5", 4", or 8" 304 series stainless steel thermowell. The thermowell has a 1/2" external or process NPT threads and 1/2" internal or instrument NPT thread. All of the thermowells will accept a probe diameter of 0.250".

■STRAP-ON TEMPERATURE TRANSMITTERS

The Strap-On transmitters are provided in a junction box with an adjustable 2" to 5" pipe clamp. The unit should be mounted on the bottom side of the pipe to ensure good temperature transfer. In hot water applications (over 150°F) it is recommended that the transmitter be remote located so as not to exceed the operating temperature of the transmitter. Extra straps may be ordered for larger diameter pipes.

■OUTSIDE AIR TEMPERATURE TRANSMITTERS

The Outside Air transmitters are provided in two parts including a weatherproof enclosure and a 2" X 4" junction box. The sensors will be mounted in the weatherproof enclosure and mounting hardware is provided. The transmitter will be provided in the 1 gang junction box and should be mounted on an inside wall so as not to exceed the operating temperature limits of the transmitter. This sensor should be mounted on either the North side of the building or anywhere out of direct sunlight with the sensor probe pointed downward. Weatherproof Aluminum Bell Boxes and NEMA 4X Polycarbonate enclosures are available upon request.

■STAINLESS PLATE TEMPERATURE TRANSMITTERS

The Stainless Plate temperature transmitters are mounted on the back of a 2" x 4" stainless plate. The sensor is covered with a 1/8" foam insulation, which allows the sensor to sense the actual room temperature and ignore any heat produced by the transmitter or drafts from within the wall. All mounting screws are provided.

■TROUBLESHOOTING

No reading	No power to board - check voltage at power terminal - should be between +8 and 35 VDC
Reading too low	RTD wires shorted - check with ohmmeter - should be close to either 100 or 1000 Ohms Improper range of transmitter (too low) - check current - should be between 4 and 20mA
Reading too high	RTD opened - check with ohmmeter - should be close to either 100 or 1000 Ohms Improper range of transmitter (too high) - check current - should be between 4 and 20mA
RF Interference	Input power must be clean. Use twisted wires or shielded cable. RF resistant power supply Use a shielded cable to connect the sensor -- connect the shield to ground Encase the board in a RF shielded enclosure

