

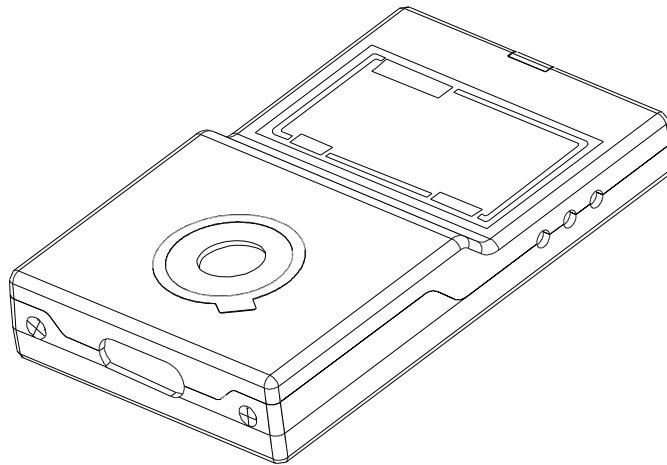

**ITS-M5
TOXIC GAS
TRANSMITTER/SENSOR**



**INSTALLATION
OPERATION AND MAINTENANCE
MANUAL**

INTEC Controls
9730 Distribution Ave., San Diego, CA 92121
Phone: (858) 578-7887 Fax: (858) 578-4633
www.inteccontrols.com
email – info@inteccontrols.com

**ITS-M5 Configuration:
Default Settings**

| | | | Factory Settings | User Settings |
|-----|--------------------------------------|-------|-----------------------------|--------------------------|
| 1. | Signal | 4 mA | See Table Below | _____ |
| | | 20 mA | See Table Below | _____ |
| 2. | Password | | 0017 | _____ |
| 3.* | Relay 1 Actuation | | Enabled | _____ |
| 4. | Relay 1 Setpoint (Actuation) | | See Table Below | _____ |
| 5. | Relay 1 Release Point (De-Actuation) | | See Table Below | _____ |
| 6. | Relay 1 Actuation Delay | | 0 Minutes | _____ |
| 7. | Relay 1 De-Actuation Delay | | 0 Minutes | _____ |
| 8.* | Relay 2 Actuation | | Enabled | _____ |
| 9. | Relay 2 Setpoint (Actuation) | | See Table Below | _____ |
| 10. | Relay 2 Release Point (De-Actuation) | | See Table Below | _____ |
| 11. | Relay 2 Actuation Delay | | 0 Minutes | _____ |
| 12. | Relay 2 De-Actuation Delay | | 0 Minutes | _____ |
| 13 | Communication Protocol | | Optomux | _____ |
| 14. | Digital Address | | 0001 | _____ |
| 15 | Baud Rate | | 4800 | _____ |

Note: Relay setpoints are included in the software; however relays are optional.

| Gas Type | 4 mA Default | 20 mA Default | Relay 1 (Warning) (If Applicable) | | Relay 2 (Alarm) (If Applicable) | |
|-----------------|--------------|---------------|--------------------------------------|---------------|------------------------------------|---------------|
| | | | Setpoint | Release Point | Setpoint | Release Point |
| NO ₂ | 0 ppm | 6.0 ppm | 1.0 ppm | 0.8 ppm | 3.0 ppm | 2.5 ppm |
| CO | 0 ppm | 125 ppm | 25 ppm | 20 ppm | 50 ppm | 40 ppm |
| NO | 0 ppm | 100 ppm | 25 ppm | 20 ppm | 50 ppm | 40 ppm |
| NH ₃ | 0 ppm | 50 ppm | 25 ppm | 20 ppm | 35 ppm | 30 ppm |
| O ₂ | 0% | 25% | 19.50% Decreasing | 20.00% | 23.00% Increasing | 22.00% |

Table Of Contents

| | |
|--|-----------|
| <i>Default Settings</i> | 1 |
| 1. PRINCIPLES OF OPERATION | 3 |
| 1.1 DISPLAY..... | 3 |
| 1.2 KEYPAD AND FUNCTION CONFIGURATION..... | 3 |
| 1.3 PASSWORD..... | 4 |
| 1.4 OUTPUT SIGNALS..... | 4 |
| 1.5 METER JACKS..... | 4 |
| 1.6 SIGNAL AND DISPLAY RANGE..... | 4 |
| 1.7 OPTIONAL RELAY PACKAGE..... | 5 |
| 1.8 DEFAULT CONDITIONS..... | 5 |
| 1.9 SENSING AND CALIBRATION..... | 5 |
| 1.9.1 <i>Calibration</i> | 5 |
| 1.9.2 <i>Implications for Troubleshooting</i> | 5 |
| 2. FUNCTION AND CONFIGURATION | 6 |
| 2.1 MENU STRUCTURE AND USE..... | 6 |
| 2.2 CONFIGURATION AND CALIBRATION..... | 7 |
| 2.3 HARDWARE CONFIGURATION..... | 13 |
| 2.3.1 <i>Output Signals</i> | 13 |
| 2.3.2 <i>RS-485 End-of-Line Wiring and Termination</i> | 13 |
| 2.3.3 <i>Battery</i> | 14 |
| 2.4 GAS CALIBRATION..... | 14 |
| 2.4.1 <i>Equipment Required</i> | 14 |
| 2.4.2 <i>Procedure</i> | 15 |
| 2.4.3 <i>Calibration Errors</i> | 15 |
| 3. FAULTS | 16 |
| 3.1 SELF-CHECK FAULTS..... | 16 |
| 3.2 HARDWARE FAULTS..... | 18 |
| 4. WIRING AND POWER SUPPLIES | 19 |

ITS-M5 Operating Manual

1. Principles of Operation

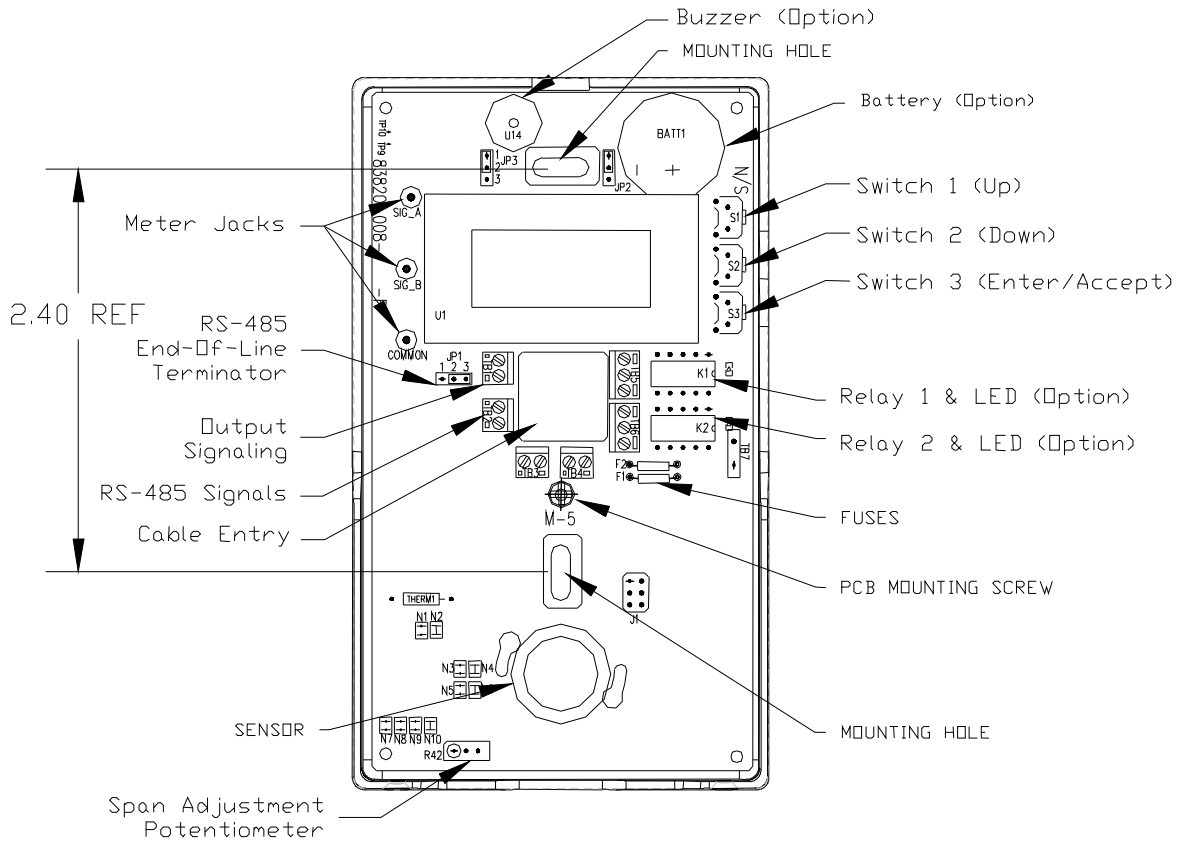

Figure 1 ITS-M5 Internal View - Features

1.1 Display

The display module is a 2-line by 8-character LCD. Standard reading in operation is

Gas Type
xxx Units

1.2 Keypad and Function Configuration

Relay settings and other configurable items are accessed through the keypad and menu display.

The keypad is a set of 3 buttons recessed along the upper right side of the enclosure. It is not necessary to open the cover for use of the keypad. Access to the menus is password restricted. Press any key for 3 seconds to enter the menus. (See below for details)

1.3 Password

Factory preset default password is 0017.

Password can be changed. **RECORD PASSWORD IN A SECURE PLACE. If the password is lost, the unit must be returned to the factory to be reset.**

1.4 Output Signals

Options are 4-20 milliamp or 2-10 VDC linear. Choose the option by moving the jumper on JP3. On over range concentrations the signal can exceed the range slightly.

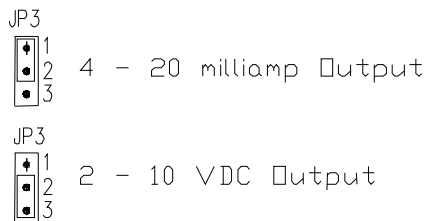

Figure 2 Signal Configuration JP3

IMPORTANT: Voltage monitoring should be into a monitor with at least 50 000 ohms input impedance. Voltage monitoring is not recommended over long distances, as these signals are more susceptible to induced noise than current signals

1.5 Meter Jacks

Test pads accepting standard test probes are provided on the circuit card. These are labeled SigA, SigB and Common

To test milliamp signals measure:

- SigA to Common shorts to internal ground.
- SigA to SigB without interrupting signal to monitor

To Test voltage signals measure:

- SigB to Common.

1.6 Signal and Display Range

It is important to distinguish between Signal Range (often called Span) and Display Range.

- § Display Range is the range of concentrations the unit is capable of displaying (which is the same concentration it will report on the digital communications). The display range varies with the gas type.
- § Signal Range is the assignment of the 4 to 20 mA signal. Default assignment of 4 mA is zero concentration. The default setting for 20 mA varies with the gas type.

The Signal range is fully adjustable within the limits imposed by the Display Range. Both the 4 mA level and the 20 mA level can be reassigned through the menu system. Please note that this adjustment does not change the measurement resolution.

1.7 Optional Relay Package

Two relays are supplied; single pole double throw (SPDT; Form C) 1 Amp. Dry contacts only. Configuration allows setpoint adjustment for actuation point, dead-band, and delays, increasing or decreasing concentrations. The relay settings have the same range as the Display Range, and are independent of Signal Range.

1.8 Default Conditions

Default conditions are those conditions, which occur:

- During the short wait state on Power On.
- In Fault status.
- In the menu tree.

In these situations the following conditions hold:

- Signal set at 4.0 milliamps (2 Volts)
- Relays set non-energized.
- Digital communications report 0; no alarm status and 4 milliamp equivalent signal.

1.9 Sensing and Calibration

Sensor type: Various electrochemical.

1.9.1 Calibration

The sensor is strongly linear in its response to gas. It is therefore straightforward to calibrate. Two gases are needed for calibration: Zero gas (clean air) and an appropriate span gas. Adjustment is by one potentiometer on the circuit board.

1.9.2 Implications for Troubleshooting

The microprocessor will detect various component faults and out-of-range conditions, and drop the output signal to 0.0 milliamps. When a fault is detected, both relays will be deactivated as well. However, it cannot detect simple out of calibration conditions, which can only be detected by applying a gas standard.

2. Function and Configuration

2.1 Menu Structure and Use

Note: While the keypad functions are available without opening the case. It is necessary to open the case to apply the calibration gases. The 'keypad' switches are located in the upper right side of the enclosure. See Figure 1 Page 3.

Display: The display is 2 line by 8 character alphanumeric. The top line contains the feature name and the second contains the variable.

Keypad: The keypad consists of three (3) pushbutton switches.

| | |
|----|--------------|
| S1 | Scroll Up |
| S2 | Scroll Down |
| S3 | Enter/Accept |

Display at Turn-On:

The display shows the following for about 2 seconds:

ITS-M5
Vx.xx Ry

Where: x.xx = the Software Version
 y = the Software Revision

Followed for about 2 seconds by:

ElectrCh
Vx.xx Ry

Where: ElectrCh = Electrochemical
 x.xx = the Sensor Algorithm Version
 y = the Sensor Algorithm Revision

Display in Operation: The display shows

GAS
xxx Units

Where GAS will show the target gas, and xxx is concentration of the gas. Units may be either ppm (parts per million) or %.

Note: Should the concentration equal or drop below an internal value, the unit will flash "CALIBR" on display line 2 every 8 seconds.

Menu Activation: Press and hold any key for 3 seconds to enter the menu tree.

Menu Scrolling: Use the scroll buttons to scroll up and down through the menu tree.

Data Entry Mode: Enter the data entry mode by pressing S3 (Enter) while displaying any feature. This mode is indicated by an * (asterisk) at the right of the variable, and indicates that the variable may be changed by scrolling. Press S3 (Accept) to save result and return to menu tree. While in data entry mode, the Up and Down keys perform an automatic key repeat while the key is held in.

Password: The first item on entering the menu tree is a Password request. The display is 0000, the default password is 0017. The * appears, indicating that a number can be entered and accepted. This number can be changed by the user (see below).

Fault: In case of faults, the display will read FAULT and a fault code in the bottom LCD line (see below). Signal will drop to 0 milliamps.

See section 3 below for more information on faults.

2.2 Configuration and Calibration

| Gas Type | Display Range | Warning (Relay 1) | W-Deact | Alarm (Relay 2) | A-Deact | 20 mA Default |
|-----------------|---------------|----------------------|---------|----------------------|---------|---------------|
| NO ₂ | 0-10.0 ppm | 1.0 ppm | 0.8 ppm | 3.0 ppm | 2.5 ppm | 6.0 ppm |
| CO | 0-250 ppm | 25 ppm | 20 ppm | 50 ppm | 40 ppm | 125 ppm |
| NO | 0-200 ppm | 25 ppm | 20 ppm | 50 ppm | 40 ppm | 100 ppm |
| NH ₃ | 0-100 ppm | 25 ppm | 20 ppm | 35 ppm | 30 ppm | 50 ppm |
| O ₂ | 0-25 % | 19.50% Decreasing | 20.00% | 23.00% Increasing | 22.00% | 25% |

Table 1 Default Settings

Note: The user has control of all variables, including calibration gas concentrations, alarm settings and signal range (both 4 milliamp and 20 milliamp) assignments. It is important to note that these must be chosen carefully with regard to calibration. Zero calibration is done through a menu option, Span calibration is done though a potentiometer on the circuit card, not through the menu system, and so it is possible to perform the adjustment without the menu system; however, the menus do offer **disabling of output actuation**.

1. Press any key for 3 seconds to enter menu system
2. Password Control

PASSWORD

0000 *

Press up/down to choose correct password and accept.

3. Factory Settings Sub-menu Branch

FACTORY

Settings

This function is for factory setup and test only.

4. **Relay 1 Sub-menu Branch**

RELAY 1

Settings

Press Enter to proceed to the Relay 1 Settings sub-menu (press down/up to skip Relay 1 Settings and go to next/previous menu item or sub-menu).

4.1 RELAY

Enable

Press Enter to change. “*” Indicates to use scroll buttons to toggle between Enable, Disable or Latching. Press Accept when done.

Note that this disables the physical relay, but not the setpoint. Setpoint actuation status will still be transmitted on the digital communications link if queried.

When the “Latching” option is selected, the relay will not de-actuate unless it is cancelled by pressing one of the keyboard buttons. The relay will only reset if the alarm situation has dissipated.

Enable is the default.

Press Down button to continue through Relay 1 Settings branch. Press Up to return to Main Menu (and Relay 1 Settings sub-menu branch).

4.2 Actuation Setpoint

ACTUATE

00XX ppm (or %)

Choose the concentration of Gas. Up/Down scrolls up/down in the Relay 1 Settings branch.

4.3. De-Actuation Setpoint

DEACT
00XX ppm (or %)

Choose the concentration of the gas at which you want the alarm condition to stop.

Note: If the De-Actuation Setpoint is set at a higher concentration than the Actuation setpoint, then the setpoint function reverses and actuates on decreasing concentrations.

Note: The software will not allow the user to set Actuation = De-actuation. If Actuation is set equal to De-actuation, the Actuation Setpoint will be adjusted upward by 10% of display range automatically before saving the new settings.

4.4 Actuation Delay.

ACT-TIME
00 min

Adjust the amount of time delayed before the relay is actuated after the Actuation Setpoint is reached. A maximum of 60 minutes is possible, adjustable in 5-minute increments.

Default is 0000.

4.5 De-Actuation Delay.

DEACTIME
00 min

Adjust the amount of time delayed before the relay is released after the De-Actuation setpoint is reached. A maximum of 60 minutes is possible, adjustable in 5-minute increments. Default is 00.

4.6 Buzzer.

BUZZER

Disable (or Enable)

The internal buzzer can be activated together with Relay 1 if 'Enable' is selected. The buzzer is silenced by pressing any of the key buttons during normal operation. Selecting 'Disable' only disables the buzzer activation for Relay 1. Buzzer operation respective to Relay 2 is set in the 'Relay 2 Settings' Sub-menu.

Note: If the buzzer is enabled for any of, or both the relays, the first key press will silence the buzzer (buzzer acknowledge) and a second key press is needed if any, or both of the relays is set for 'Latching' mode. Refer to 3.1 above.

To configure the buzzer for Relay 2 operation, go the 'Relay 2 Settings' sub-menu.

Default is Disabled.

The Up key scrolls back up the Relay 1 Settings sub-menu branch. The Down key leaves the Relay 1 Settings sub-menu branch and returns to the Relay 1 Settings main menu item.

5. Relay 2 Sub-menu Branch

RELAY 2
Settings

Press Enter to access the settings. The sub-menu structure is the same as for Relay 1 Settings.

6. Range Adjustments

CONC4MA
0000 ppm (or %)

This feature allows adjustment of the 4 milliamp point to non-zero gas concentrations. The display will always read as low as 0000, but the concentration corresponding to 4 milliamps changes.

Maximum: Display Range
Minimum: 0

Note: An inverted response at the signal output can be achieved by setting CONC4MA higher than CONC20MA.

Note: Changing the range in this fashion does not enhance the gas measurement accuracy.

7. Range Adjustments

CONC20MA
0XXX ppm (or %)

This feature allows adjustment of the 20 milliamp point to different gas concentrations. The display will always read as low as the maximum for that gas but the concentration corresponding to 20 milliamps changes. Note that the display maximum is not affected by this adjustment.

Maximum: Display Range
Minimum: 0

Note: An inverted response at the signal output can be achieved by setting CONC4MA higher than CONC20MA.

Note: changing the range in this fashion does not enhance the gas measurement accuracy.

Note: The software will prevent the user from setting the 4mA point = 20mA point. In such a case, the 20mA point will be lifted by 10% of Display Range before saving the settings.

8. Calibration:

8.1 Calibrate Zero Gas

CAL ZERO
000 ppm (or %)

Apply Zero Gas (clean air). Wait to stabilize. Press Enter. The unit will automatically reset the display to 000.

8.2 Calibrate Span

Calibration is done with the potentiometer on the circuit card, not through the menu system, and so it is possible to perform the adjustment without the menu system; however, the menus do offer disabling **of output actuation**.

CAL SPAN
XXX ppm (or %)

Calibration Procedure:

Apply an appropriate span gas, and adjust the Gain potentiometer to get the correct reading on the display.

Press Up/Down to go to the next/previous menu item.

9. Communications Protocol

PROTOCOL

Optomux

The Optomux protocol (default) communicates with IM-Control.
The B4000 protocol communicates with IQDC-4000 monitor.

Press Enter and Up/Down to select the desired protocol.

10. Digital Address

ADDRESS

0001

Allows changes to the digital communications address for the transmitter.

Note: The new address is available **immediately it is accepted at this point**, and the unit will respond to only this address when queried even though you are still inside the main menu tree. If you abort the main menu tree (see below) then the address will revert to the previous address.

Optomux maximum: 256

B4000 maximum: 16

Note: If the B4000 protocol was selected (above), all previously set addresses higher than 16 will be folded back to address 16.

11. Baud Rate

BAUDRATE

4800

Default is 4800 baud.

Options: 600, 1200, 2400, 4800 and 9600

12. Change Password

PASSWORD
0000

Factory default is 0017.

Press Enter and scroll up and down to choose a new password. **RECORD
PASSWORD IN A SECURE PLACE.**

Note: This item displays the current password, so it is important to keep security in mind when passing this item in the presence of bystanders.

If the password is lost, the unit must be returned to the factory to be reset.

13. Exit Menu Tree

EXIT
Save

Press Enter, an * will appear beside Save. Press Up/Down to choose Save or Abort. Press Enter/Accept to exit.

Note: Choosing Abort will discard all changes made since last entering the menu system, including calibration values.

2.3 Hardware Configuration

2.3.1 Output Signals

Options are 4-20 milliamp or 2-10 V linear. Choose the option by moving the jumper on JP3. On over-range concentrations the signal can exceed the range slightly.

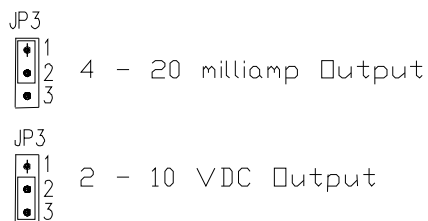

Figure 3 Signal Configuration

2.3.2 RS-485 End-of-Line Wiring and Termination

RS-485 installations require specialized wiring. A number of manufacturers make cable especially for this wiring standard (EIA-485), (e.g. Belden 9841). This is a twisted, shielded, balanced pair, 24 AWG, 120 Ohm. In order to prevent signal bounce-back and

other distortions, it is necessary to provide a balancing resistor across both ends of the wire. The ITS-M5 supplies this resistor on board, and it is chosen using a jumper at JP1.

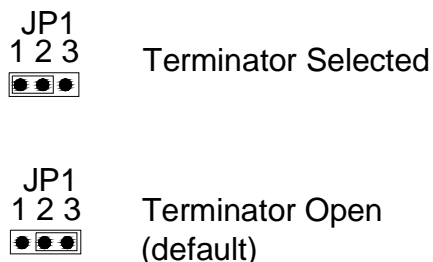

Figure 4 RS-485 End-of-Line Termination

2.3.3 Battery

Certain sensors (NH₃, NO) require active power even when the unit as a whole is powered down. This is done to prevent excessively long stabilization periods on turn-on. Disable the battery using JP2 when the unit is powered down without a sensor cell present. The battery is not consumed when the unit is powered.

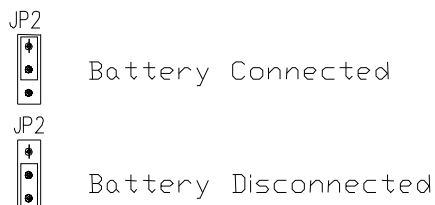

Figure 5 Battery Connection Enable

2.4 Gas Calibration

Calibration should not vary significantly over a period of years; however, it is best to perform a verification calibration after installation, and at one-year intervals thereafter. All units are factory calibrated.

2.4.1 Equipment Required

- Zero air, (clean air or nitrogen).
- Appropriate span gas as close to the range of interest as possible
- Pressure and Flow Limiting Regulator(s) **0.4 to 0.8 lpm (0.8 to 1.6 scfh)**
- Tubing and bayonet adapter.

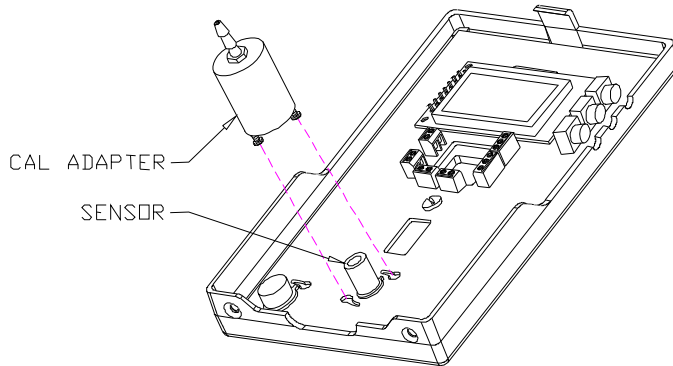

Figure 6 Calibration Gas Bayonet Adapter

2.4.2 Procedure

Calibration Procedure:

Enter the configuration menu system and proceed to “CAL ZERO”. This disables alarm outputs, and forces the output signal to 4.00 milliamps.

Response of these sensors to gas varies with the sensor, but in most cases the signal should be sufficiently stable in less than 5 minutes. Pre-calibration stabilization times vary from 24 hours (CO and NO₂) to a week or more (NH₃).

Apply zero gas (clean air) and wait for the display reading to stabilize. (Remember that the 4-20 milliamp signal may be set to a different range.) Press Accept to automatically zero the reading.

Press Down to go to CAL SPAN.

Apply an appropriate span gas, and adjust the Gain potentiometer to get the correct reading on the display.

On removing the gas, you may find that the display does not completely re-zero. Return to CAL ZERO to re-Zero. Note: Allow enough time for the sensor to stabilize at zero in order not to set an incorrect zero calibration.

2.4.3 Calibration Errors

If the gas flow was not sufficient, or the bayonet adapter was too loosely applied, the gas concentration in the sensor will stabilize at an incorrect low value.

3. Faults

3.1 Self-check Faults

The microprocessor monitors a number of operational values for faults, and will display each occurrence for two seconds as follows:

FAULT
XXX

Where XXX is a fault code.

The unit will automatically restart and continue normal operation if the fault occurred due to a temporary intrusion (e.g.: Radio frequency interference or water condensation formed due to fast temperature change).

A fault shown repeatedly indicates malfunction of the unit. In such cases the fault code should be recorded and the unit returned for repair.

When a fault is detected, the output is dropped to 0.0 mA and both relays are deactivated.

The only Self Check Faults which can be field addressed are those which refer to problems with the sensor (fault code 048):

- Check that the sensor is inserted in its socket correctly.
- Replace sensor. If the fault is removed, then re-calibrate.
- Return unit to Factory.

Beep Codes:

One short beep, followed by 5-second silence, accompanied by blank LCD, indicates a faulty LCD, return to factory for repair.

Note: The unit performs a standard short beep at power-up.

Fault Codes:

| Fault Code | Description | Action |
|-----------------------------|--|--|
| Audible | | |
| 001 | LCD Fault (1 beep, 5 second silence) | Return unit to factory for repair if fault persists. |
| EEPROM | | |
| 008 | FLASH EEPROM write time-out. | Return unit to factory for repair if fault persists. |
| 009 | Data EEPROM write time-out. | |
| 010 | FLASH EEPROM verify error when writing. | |
| 011 | Data EEPROM verify error when writing. | |
| 012 | Last EEPROM write interrupted, incomplete. | |
| Analog Output Signal | | |
| 032 | Driven output higher than monitored output. | Return unit to factory for repair if fault persists. |
| 033 | Driven output lower than monitored output. | |
| 034 | Voltage output load too large (or mode fault). | |
| 035 | Voltage output load driving into unit. | |
| System | | |
| 024 | Out of ms timers. | Return unit to factory for repair if fault persists. |
| 025 | Out of second timers. | |
| 026 | Message queue overflow. | |
| Sensor | | |
| 040 | Sensor front-end or heater driver fault. | Check sensor, replace sensor and calibrate. |
| 041 | Pseudo ground level too low. | |
| 042 | Pseudo ground level too high. | Return unit to factory for repair if fault persists. |
| Calibration | | |
| 048 | Concentration too far negative. | Calibrate. Return unit to factory for repair if fault persists. |
| Mathematics | | |
| 056 | 32-bit scale operation overflow. | Calibrate. Return unit to factory for repair if fault persists. |
| 057 | Floating-point overflow. | Calibrate. Return unit to factory for repair if fault persists. |
| 058 | Floating-point underflow. | Calibrate. Return unit to factory for repair if fault persists. |
| 059 | Floating-point divide by zero. | Calibrate. Return unit to factory for repair if fault persists. |
| 060 | Floating-point domain error exception. | Calibrate. Return unit to factory for repair if fault persists. |

3.2 Hardware Faults

| | |
|---|---|
| Screen Blank, no Signal | Check wiring, check fuses. |
| Distorted Milliamp Signal | Output jumper set to voltage. |
| Voltage signal pinned high | Output jumper set to milliamps |
| No milliamp Signal on AC floating power supply | Check for signal common line. Check for signal operation by using on-board test points |
| Bad RS-485 Communications for this unit. | Check wiring polarity for A & B lines Check for correct line terminations. Check for correct address. Check for correct Baud rate and protocol. |
| Bad RS-485 Communications for a multi-drop group. | Check wiring polarity for A & B lines Check for correct line terminations. It is possible for one failed device on a multi-drop line to pull communication down for the whole line. Check for correct addresses, Baud rate and protocol selection. |

4. Wiring and Power Supplies

The ITS-M5 Power Supply input is not isolated internally from the electronics and thus the signal common. Therefore, while the power supplied may be AC or DC, care must be taken to avoid the creation of multiple grounds (or a ground loop).

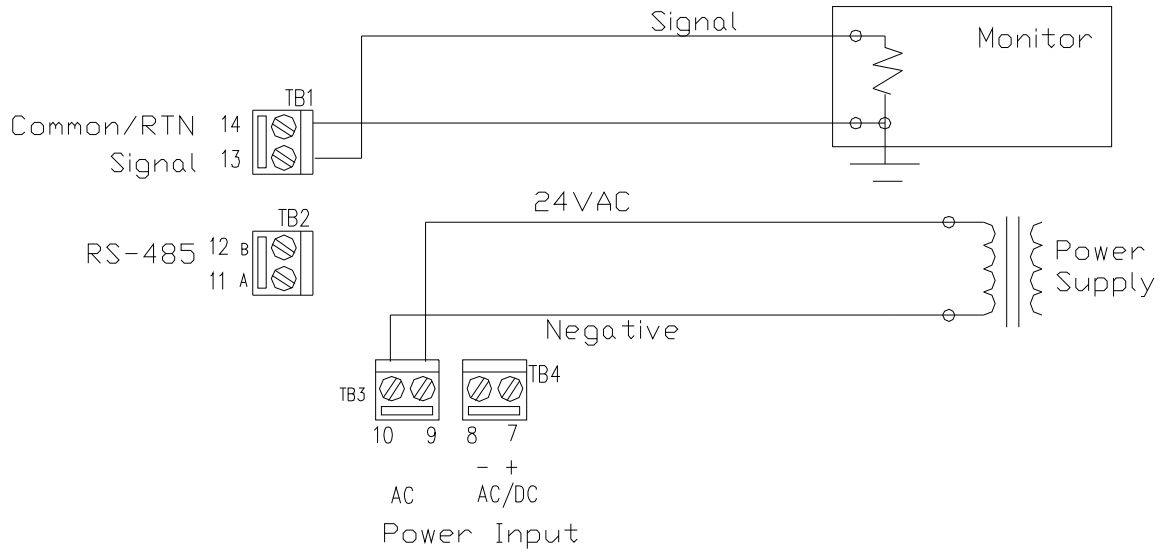

Figure 7 24VAC Floating Supply 4-Wire Installation

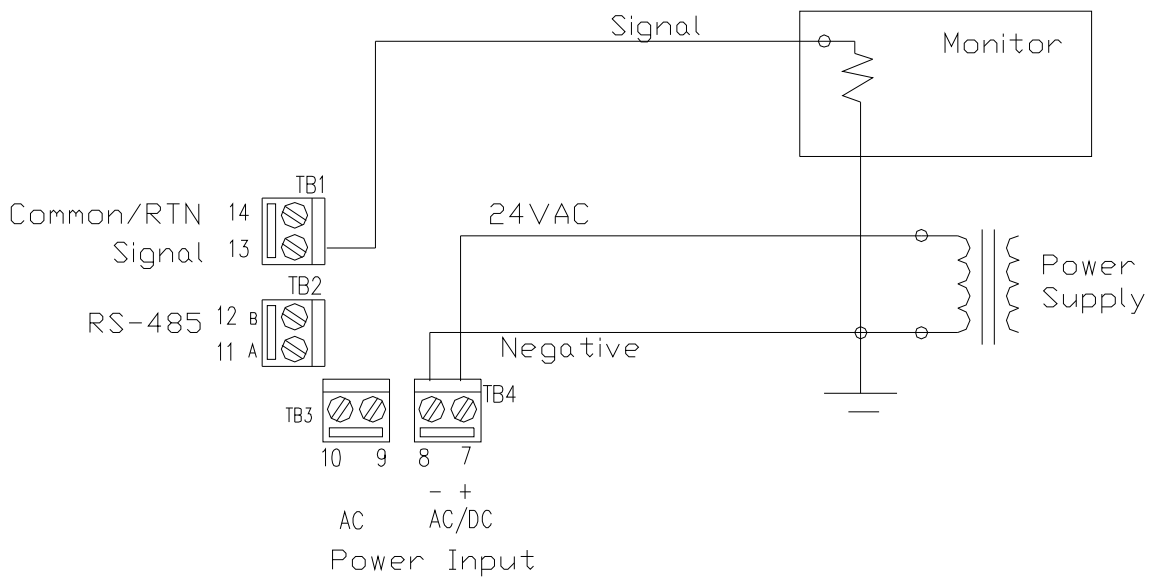

Figure 8 24VAC with Common Grounds - 3-Wire Installation

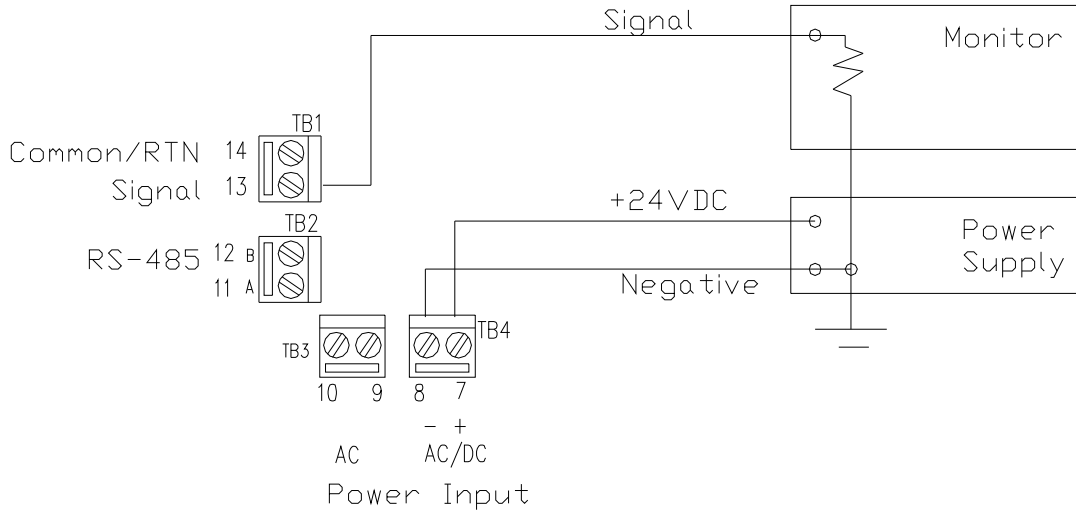

Figure 9 24VDC Supply with Common Ground - 3-Wire Installation

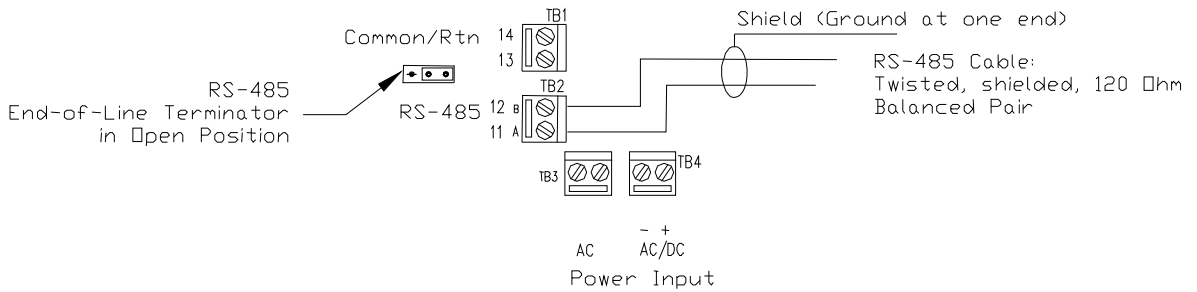

Figure 10 RS-485 Connection

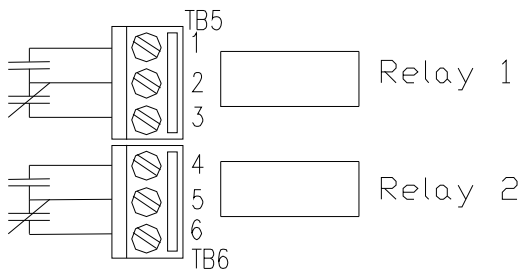

Figure 11 Relay Connections