



PolyGard® Single Point Controller SPC3-3300

Single Point Gas Controller for Combustible Gases

Serial Number _E_1008

User Manual

October, 2008

- 1 Description..... 4**
- 2 Operating Instruction..... 5**
 - 2.1 Description Keypad User Interface 5
 - 2.2 Setting / Changing Parameters or Set points..... 5
 - 2.3 Code Levels 6
- 3 Menu Overview 6**
 - 3.1 Fault Management 7
 - 3.1.1 Acknowledge a Fault..... 7
 - 3.1.2 Error Memory 7
 - 3.1.3 System Errors 8
 - 3.2 Status Alarm..... 8
 - 3.3 Status Relay 9
 - 3.3.1 Manual Operation of the Relays 9
 - 3.4 Menu Measuring Values 10
 - 3.5 Menu Relay Parameters 10
 - 3.5.1 Relay Mode 11
 - 3.5.2 Relay Function Static / Flash 11
 - 3.5.3 Latching Mode 11
 - 3.5.4 Horn Function 12
 - 3.5.5 External Relay Operation..... 13
 - 3.5.6 Delay Mode of the Relay..... 13
 - 3.6 Menu SP Parameters 13
 - 3.6.1 Activate – Deactivate SP 15
 - 3.6.2 Selection Gas Type..... 15
 - 3.6.3 Measuring Range..... 16
 - 3.6.4 SP Signal..... 16
 - 3.6.5 Threshold / Hysteresis 16
 - 3.6.6 Delay of Alarm ON or OFF..... 16
 - 3.6.7 Control Mode 17
 - 3.6.8 SP Fault Assigned to Alarm 17
 - 3.6.9 Alarm Assigned to Alarm Relay 17
 - 3.6.10 SP Signal Assigned to Analog Output..... 17
 - 3.7 Menu System Parameters..... 18
 - 3.7.1 Service Mode 19
 - 3.7.2 Software Version..... 19
 - 3.7.3 Maintenance Concept 19
 - 3.7.4 Average Function 19
 - 3.7.5 System Time, System Date 20
 - 3.7.6 Customer Password (Code 1)..... 20
 - 3.7.7 Analog Output 20
 - 3.7.8 Define the Failure Relay 20
 - 3.7.9 Power On Time 21
- 4 Mounting / Electrical Connection 22**
 - 4.1 Electrical Connection 22
 - 4.2 Connection Diagram 23
 - 4.3 Connector Block / Overview SPC3 Module 24

- 5 Commissioning..... 24**
 - 5.1 Commissioning..... 24
 - 5.2 Checklist Commissioning 25
- 6 Configuration and Parameter Card..... 26**
 - 6.1 Configuration Card of System Parameters 26
 - 6.2 Configuration Card of Alarm Relays 26
 - 6.3 Configuration Card of Measuring Parameters 26
- 7 Specifications SPC3..... 27**
- 8 Gas Sensor..... 28**
 - 8.1 Description 28
 - 8.2 Calibration 28
 - 8.2.1 Zero-Point Calibration 28
 - 8.2.2 Gain Calibration 29
 - 8.2.3 Calculation Calibration Gas < >Target Gas (alternative calibration) 29
 - 8.3 Cross-sensitivity Data 29
 - 8.4 Exchange of Sensor Element..... 30
- 9 Specification Gas Sensor 30**
- 10 Notes and General Information 31**
 - 10.1 Intended Product Application..... 31
 - 10.2 Installers` Responsibilities 31
 - 10.3 Maintenance 31
 - 10.4 Limited Warranty 31

Single Point Gas Controller SPC3

1 Description

The PolyGard® SPC3 Gas Controller is used for measuring, monitoring and warning of combustible gases and vapours in the ambient air in the LEL range. A catalytic sensor (SP01) is integrated in the gas controller for combustible gases. In addition an external gas transmitter (SP02) can be connected to the controller for controlling toxic or combustible gases or even Freons. Four alarm thresholds are free adjustable for each Sensor Point (SP). Every alarm threshold can be assigned to one of the maximum 4 alarm outputs (RX). The Gas Controller can interface via the (0)4 to 20 mA or (0)2 to 10 V output signal with any compatible electronic analog control, DDC/PLC control or automation system.

The free adjustable parameters and alarm threshold make a very flexible use in the gas measuring possible. Simple and comfortable commissioning is possible due to factory adjusted parameters.

The configuration parameter settings and operation is easy to do without programming knowledge.



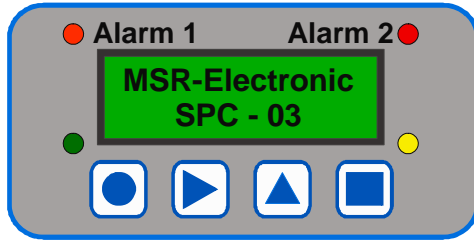

The PolyGard® Single Point Gas Controller SPC3 must not be used in potentially explosive atmospheres.

2 Operating Instruction

The complete configuration, parameterization and service are made via keypad user interface in combination with the display screen. Security is provided via two password levels.



2.1 Description Keypad User Interface

-  Exits programming, returns to the previous menu level.
-  Enters submenus, saves settings.
-  Scrolls up in main menu and submenus, increases or decreases a value.
-  Moves the cursor.

LED orange: Flashes when alarm one or more alarms are active.
Permanently on, when one of the relays is manually operated.





LED red: Flashes when alarm two or more alarms are active.
Permanently on, when one of the relays is manually operated.

LED yellow: Flashes at system or sensor failure or when maintenance needed.

LED green: Power LED

2.2 Setting / Changing Parameters or Set points

Open desired menu window.

-  Code window opens, if no code level approved.
- After input of the valid code the cursor jumps on the first position segment to be changed.
-  Push the cursor onto the position segment, which has to be changed.
 -  Change the parameter / set point.
 -  Save the changed value.

Finish

2.3 Code Levels

All changes of parameters and set point values are protected by a four-digit numeric code (= password).

The code level 1 permits the operation of the SPC- 23. This code level is intended for the customer. The code can be changed individually via code level 2.

In code level 2 all parameters and set points are released, this code level is only for the service technician.

The release of the code level is deleted if no button is pushed within 15 minutes.

All menu windows are visible without entering a code.

3 Menu Overview

The operation of the Single Point Gas Controller SPC3 is effected by a simple and logical menu structure which is easy to learn.

The operating menu contains the following levels:

- Starting menu.
- Main menu
- Submenu 1 and 2

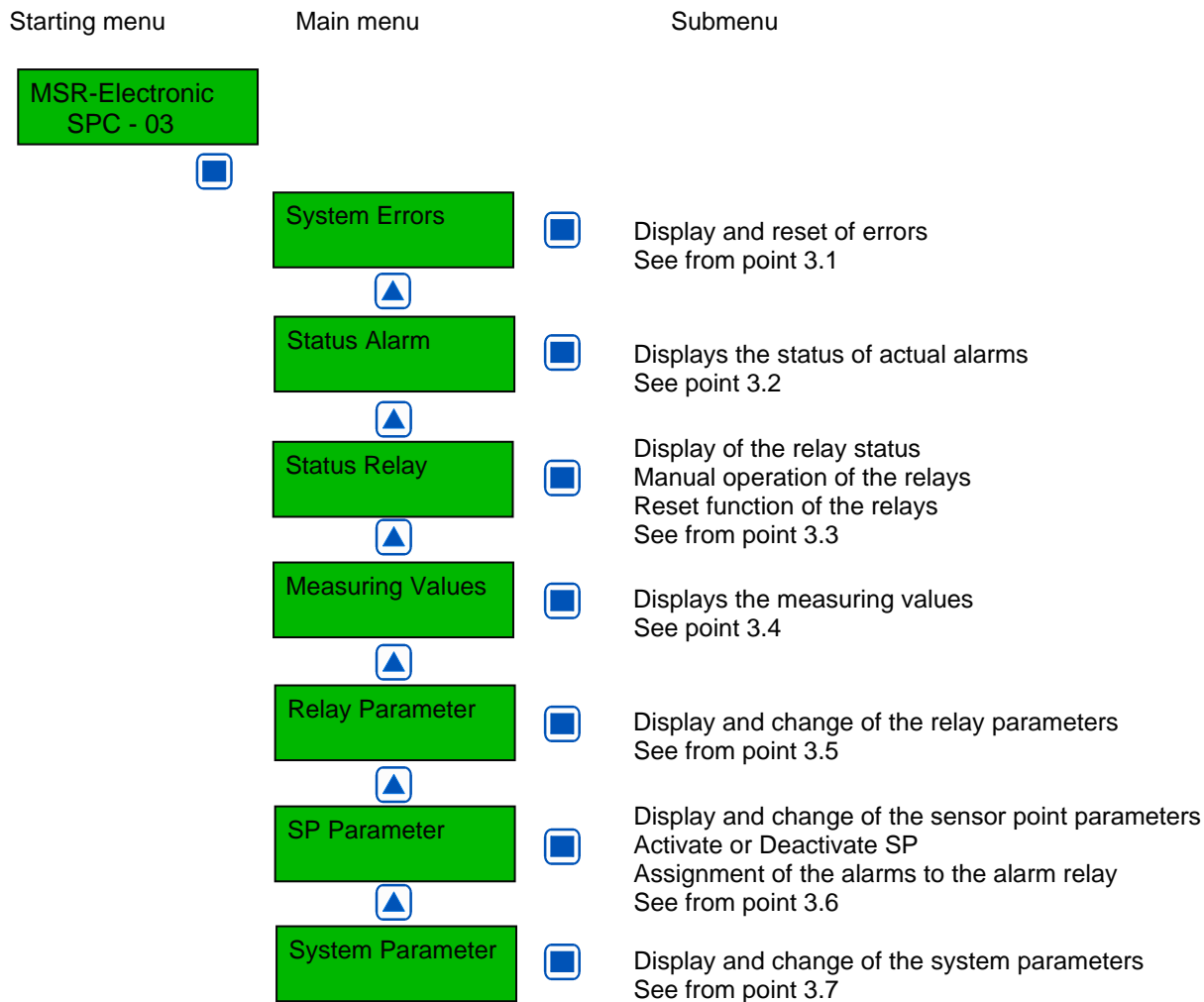

3.1 Fault Management

The integrated fault management records the last 15 faults with date and time stamps in the menu “System Errors”. Additionally a record of the faults occurs in the “Error Memory”, which can be selected and reset only by the service technician.

An actual fault is displayed in plain text in the starting menu. The failure relay which is defined in the system parameter “Failure relay” is activated. The yellow LED in the front of the gas controller flashes.

In case of fault of a sensor point (SP) the alarms defined in the menu “SP Parameter” are activated additionally.

3.1.1 Acknowledge a Fault

Attention:

Acknowledging a fault is only possible after having removed the cause.

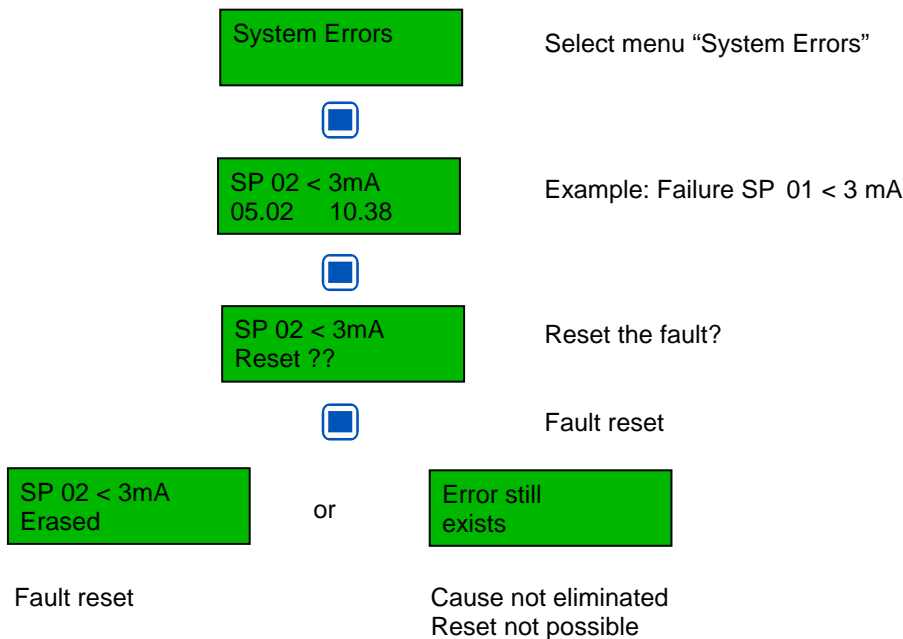

3.1.2 Error Memory

The menu “Error Memory” in the main menu “System Error” can only be opened via code level 2.

In the error memory the last 15 faults are listed for the service technician even if they were already acknowledged in the menu “System Error”. The deletion of each individual message is effected in the same way as the reset of a fault.

3.1.3 System Errors

The following system error messages are recorded:

- SP 02 > 22 mA** Current signal at analog input > 22 mA / 11 VDC. (External Transmitter)
 Cause: Short-circuit at analog input or transmitter not calibrated, transmitter defective.
 Solution: Check cable to transmitter, make calibration, replace the transmitter.
- SP 02 < 3 mA** Current signal to analog input < 3 mA / 1,3 VDC. (External Transmitter)
 Cause: Wire breaking at analog input or transmitter not calibrated, transmitter defective.
 Solution: Check cable to transmitter, make calibration, replace the transmitter.
- GC Error:** Internal communication error I/O Board to LCD Board.
 Cause: Internal error.
 Solution: Change the Gas Controller module.
- Maintenance:** System maintenance is necessary.
 Cause: Maintenance date exceeded.
 Solution: Make the maintenance.

3.2 Status Alarm

Display of the actual alarms in plain text in the order of their arrival. Only those sensor points are displayed, where at least one alarm is active. Changes are not possible in this menu.

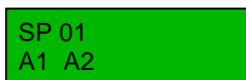

Symbol	Description	Function
SP 01	Sensor (SP) Point No.	
AX	Status alarm	A1 = Alarm 1 ON A2 = Alarm 2 ON A3 = Alarm 3 ON A4 = Alarm 4 ON

3.3 Status Relay

The SPC3 has two alarm relays (R01 / R02) and two open collector outputs (R03 / R04). In the following description they are referred to as alarm relays.

Display of the actual status of alarm relays. Manual operation of the alarm relays.



Symbol	Description	Setting Status	Function
R 01	Relay No. 01		Select Relay No.
OFF	Status relay	OFF	OFF = Relay OFF (No gas alarm) ON = Relay ON (Gas alarm) Manual OFF = Relay manual OFF Manual ON = Relay manual ON

3.3.1 Manual Operation of the Relays

The manual operation of the alarm relays is managed in the menu "Status Relay". If a relay is in the manual ON or OFF status, the orange/ red alarm LED at the Gas Controller is lit continuously.

The external operation of the alarm relay via an assigned digital input has priority to the manual operation in the menu "Status Relay" and to gas alarm.

Relays manually operated in the menu "Status Relay" are deleted again by selecting the function "Automatic".

Acknowledging the relays in latching mode is also effected in this menu.

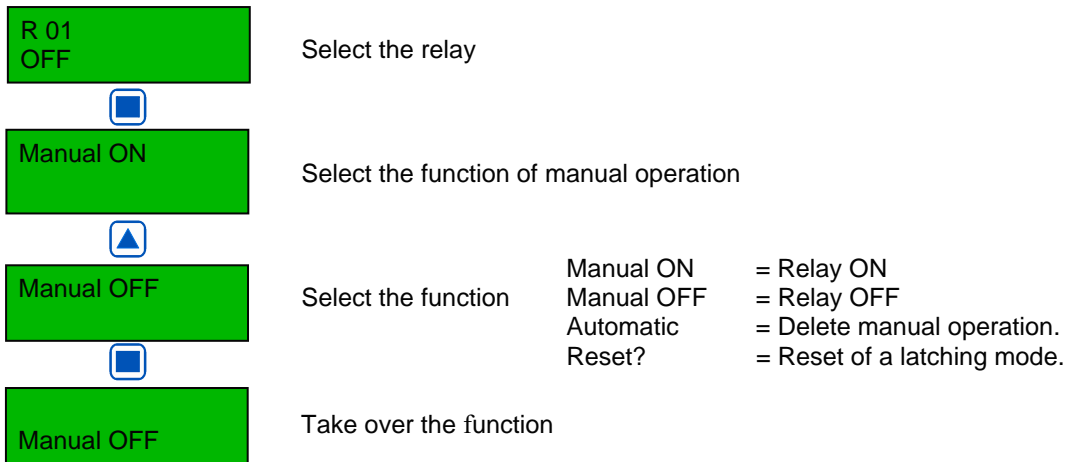

3.4 Menu Measuring Values

In this menu the current value (CV) and average value (AV) with gas unit and gas type for each active sensor point (SP) is displayed as well as the defined control mode (CV or AV mode).

```
SP 01 Ex % LEL
20 AV 33°CV
```

Symbol	Description	Setting Status	Function
SP 01	Sensor P. No.		Selection of SP No
Ex	Gas type	Ex	See 3.6.2
% LEL	Gas unit		See 3.6.2
CV	Current value	CV	Current value of gas concentration
AV	Average value		Average value (10 measured values within the time unit)
*	Control mode		Display of selected control mode (CV or AV)
Not active	Status SP	Not active	SP not active
Error	Fault SP		Current signal < 3 mA or > 22 mA

3.5 Menu Relay Parameters

Display and change of the parameters for each alarm relay

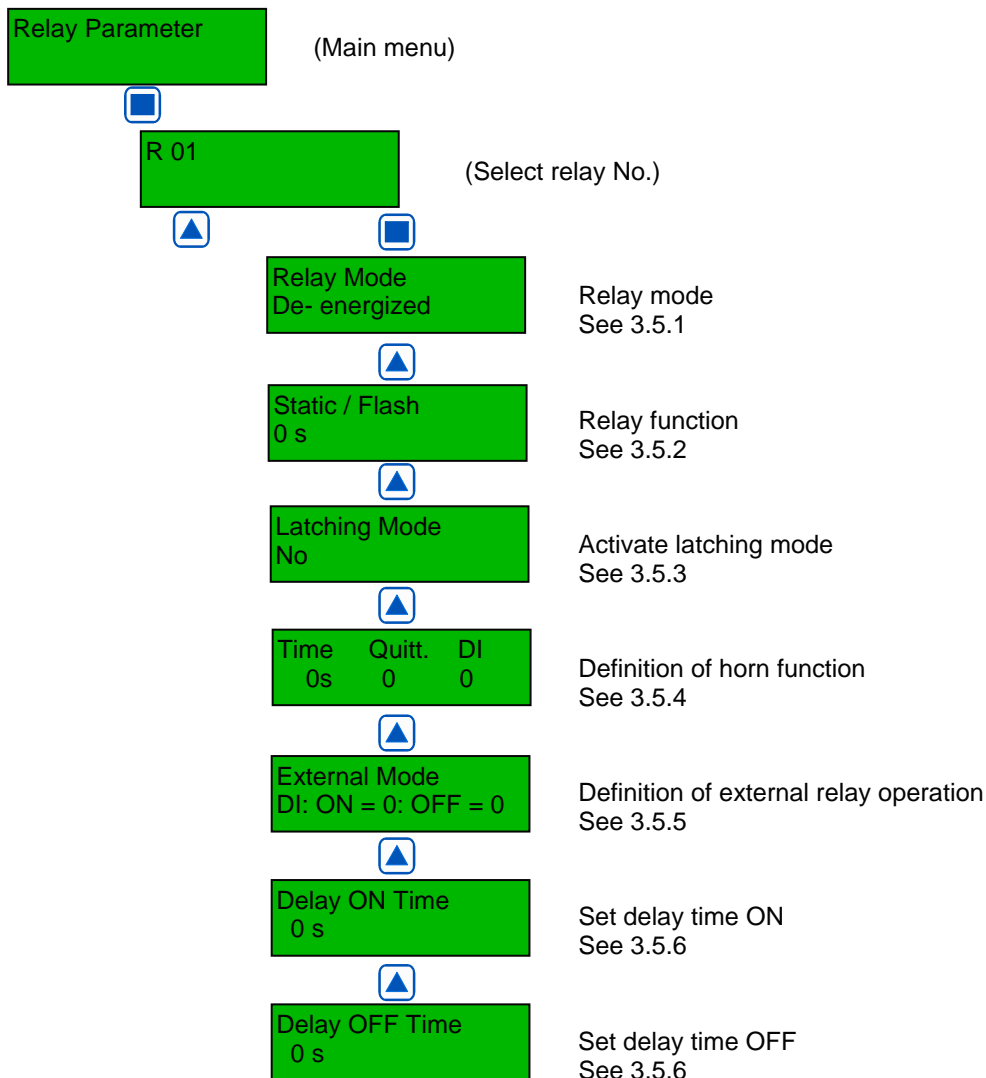

3.5.1 Relay Mode

Definition of relay mode:

Symbol	Description	Setting Status	Function
R 01	Relay No.		Selection of relay
De-energized	Relay Mode	De-energized	De-energized = Alarm ON = Relay ON Energized = Alarm ON = Relay OFF

3.5.2 Relay Function Static / Flash

Definition of relay function

Symbol	Description	Setting Status	Function
R 01	Relay No.		Selection of relay
0	Function	0	0 = Relay function static > 0 = Relay function flashing (= Time period in sec.) Impulse / Break = 1:1

3.5.3 Latching Mode

Definition of latching function

Symbol	Description	Setting Status	Function
R 01	Relay No.		Selection of relay
No	Latching Mode	No	No = Latching mode non active Yes = Latching mode active

Acknowledging a latching relay in the menu “Status Relay” is only possible if the gas concentration is again lower than the alarm threshold including hysteresis. In this case the status latching occurs in the display.

Example: Alarm relay R2 with latching mode

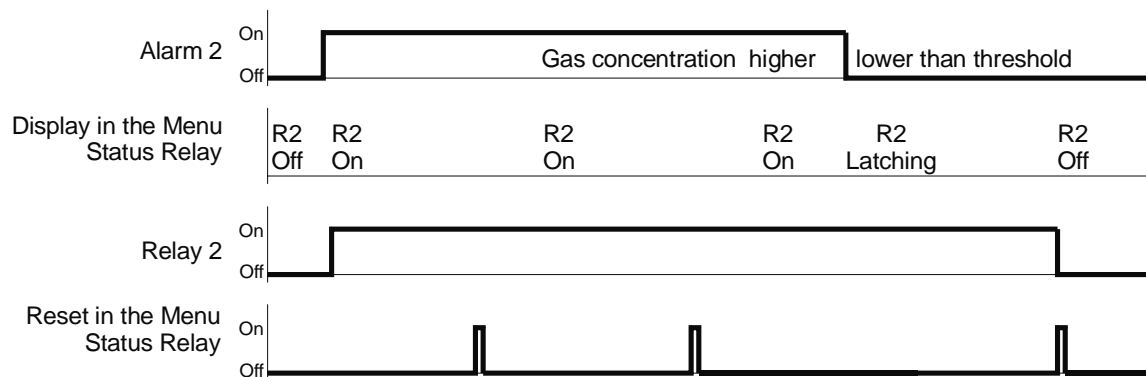

3.5.4 Horn Function

The internal horn is connected to alarm relay R3 (open collector).

This alarm output is defined as horn relay by this parameter with the following possibilities to reset.

- By pressing any of the 4 push-buttons (only possible in the starting menu).
- Automatic reset at the end of the fixed time.
- By an external push-button (assignment of the appropriate digital input).

The horn function is only activated if at least one of the two parameters (time or digital input) is set.

Special function Response

After acknowledging the output (by push-button or externally) time starts. When this time has run out and the alarm is still acting, the relay is set again.

Symbol	Description	Setting Status	Function
R 03	Relay No.		Selection of relay
Quitt	Mode	0	0 = Reset of the relay after time having run out, or by push-button 1 = Reset of the relay by push-button, after time having run out and when alarm is still acting, relay is set again. (Response function).
Time		120	Time for automatic reset function or response function 0 = no reset function
DI		0	Assignment, which digital input resets the output.

Acknowledge the horn output

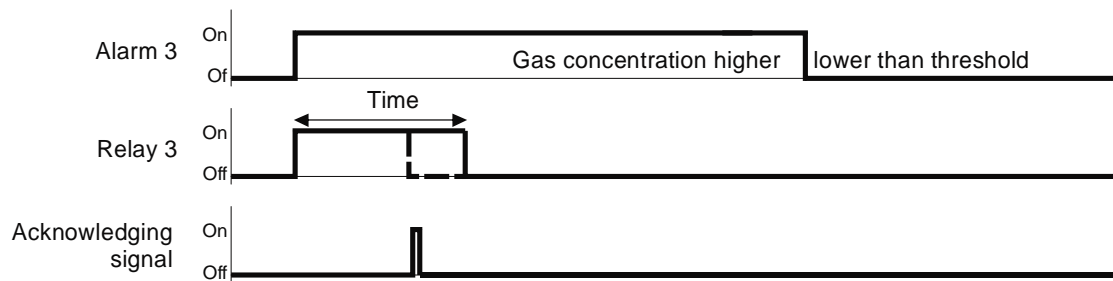

Special function „Response“. (Return of the horn relay)

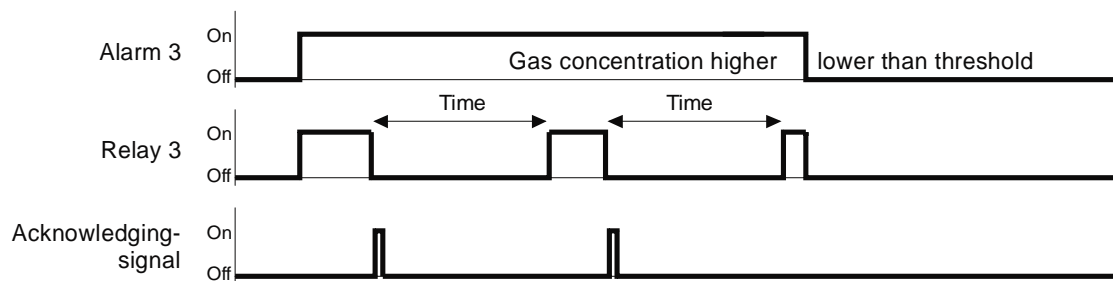

3.5.5 External Relay Operation

Assignment to a digital input (DI) for external switching of the alarm relay (ON and/or OFF). This function has priority to gas alarm and/or manual switching in the menu “Status Relay”.

Symbol	Description	Setting Status	Function
R 01	Relay No.		Relay Selection
DI-ON	External On	0	If digital input closed, relay switches ON
DI-OFF	External Off	0	If digital input closed, relay switches OFF

3.5.6 Delay Mode of the Relay.

Delay time ON starts when the alarm is released and/or delay time OFF starts when the alarm returns to normal condition.

Symbol	Description	Setting Status	Function
R 01	Relay No.		Relay Selection
0 s	Delay Time ON	0	Mode ON: Relay is only activated at the end of the defined time (sec.) 0 sec. = No delay
0 s	Delay Time OFF	0	Mode OFF: Relay is only deactivated at the end of the defined time (sec.) 0 sec. = No delay

3.6 Menu SP Parameters

Display and change of parameters, assignment of alarms to alarm relays and activation of Sensor Points (SP).

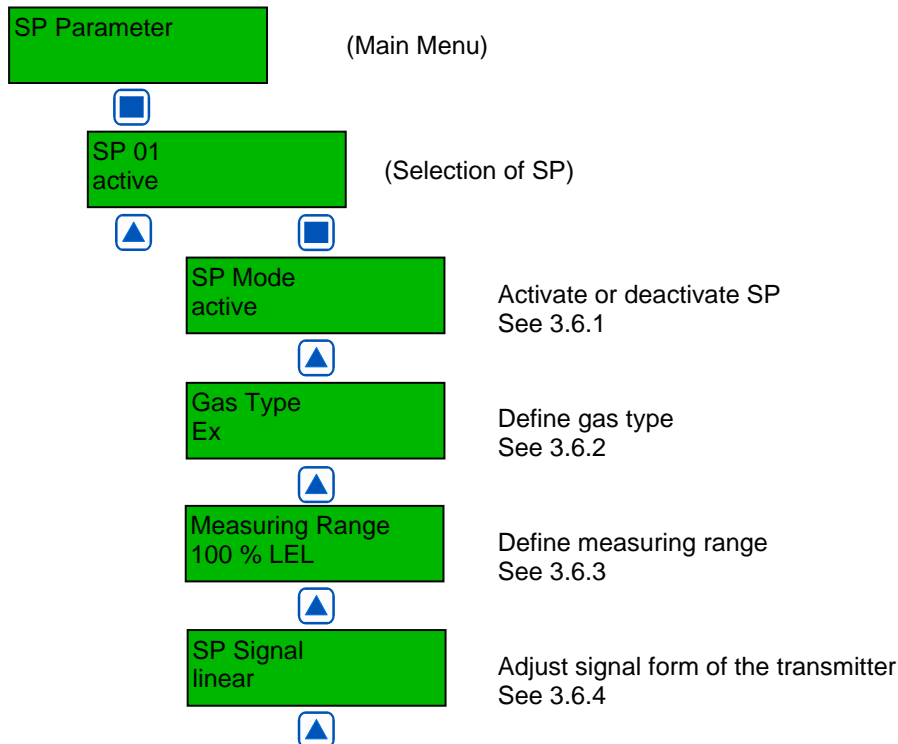

Threshold 1 20 % LEL	Define threshold 1 See 3.6.5
▲	
Threshold 2 40 % LEL	Define threshold 2 See 3.6.5
▲	
Threshold 3 40 % LEL	Define threshold 3 See 3.6.5
▲	
Threshold 4 100 % LEL	Define threshold 4 See 3.6.5
▲	
Hysteresis 5 % LEL	Hysteresis See 3.6.5
▲	
Delay ON Time 0 s	Set delay time ON See 3.6.6
▲	
Delay OFF Time 0 s	Set delay time OFF See 3.6.6
▲	
C/A Mode CV	Define control mode See 3.6.7
▲	
Alarm - 1 2 3 4 Fault - 0 0 0 0	Assign SP fault to alarm See 3.6.8
▲	
A1; A2; A3; A4 01; 02; 03; 00	Assign alarm to alarm relay See 3.6.9 and 3.6.10
▲	
Analog Output 0	Assign SP signal to analog output See 3.6.10

3.6.1 Activate – Deactivate SP

Symbol	Description	Setting Status	Function
SP 01*	Sensor point		Selection SP No.
Active	SP Status	Not active	Active = Sensor point activated at the controller Not active = Sensor point not activated at the controller

*SP01 = On Board sensor

*SP02 = Externer Transmitter (optional)

3.6.2 Selection Gas Type

Assign gas type to attached gas transmitters.

Symbol	Description	Setting Status	Gas type		Unit	Measuring range ¹
SP 01	Sensor point					
Ex	Gas type	Ex	CO	Carbon monoxide	ppm	0 – 300
			Ex	Combustible gases	% LEL	0 – 100
			NO	Nitrogen oxide	ppm	0 – 50
			NO ₂	Nitrogen dioxide	ppm	0 – 25
			NH ₃	Ammonia	ppm	0 – 300
			O ₂	Oxygen ²	%V/V	0 – 25
			CO ₂	Carbon dioxide	ppm	0 – 2000
			SO ₂	Sulphur dioxide	ppm	0 – 100
			H ₂ S	Hydrogen sulphide	ppm	0 – 200
			CL ₂	Chlorine	ppm	0 – 100
			ETC	Ethylene oxide	ppm	0 – 20
			VOC	Air quality	%	0 – 100
			R401	Refrigerant gas	ppm	0 – 2000
			R402	Refrigerant gas	ppm	0 – 2000
			R408	Refrigerant gas	ppm	0 – 2000
			R409	Refrigerant gas	ppm	0 – 2000
			R404	Refrigerant gas	ppm	0 – 300
			R416	Refrigerant gas	ppm	0 – 300
			R502	Refrigerant gas	ppm	0 – 300
			R410	Refrigerant gas	ppm	0 – 300
R411	Refrigerant gas	ppm	0 – 300			
R11	Refrigerant gas	ppm	0 – 300			
R123	Refrigerant gas	ppm	0 – 300			
R134	Refrigerant gas	ppm	0 – 300			
R22	Refrigerant gas	ppm	0 – 300			
TEM	Temperature	°C	0 – 50			
RH	Humidity	% RH	0 – 100			
CO ₂	Carbon dioxide	ppk	0 – 5000			
TOX	Toxic gas	ppm	0 - XX			

¹ Recommendation without obligation

² Decreasing signal at oxygen measurement!

3.6.3 Measuring Range

The measuring range can be defined arbitrarily between 10 and 10000. The measuring ranges in the table gas type are only recommendations without obligation.

The measuring range for SP01 (integrated gas sensor) is factory set, the measuring range for SP02 must agree with the signal (4 to 20 mA / (0)2 to 10 V) of the attached gas transmitter.

(4 mA / (0)2 V = Display 0 (ppm); 20 mA / 10 V = Display of the ultimate value of the measuring range)

3.6.4 SP Signal

Gas transmitters using electro-chemical or catalytic beat gas sensors normally produce a linear 4 to 20 mA / (0)2 to 10 V signal, proportional to the gas concentration.

Semiconductor gas sensors produce a non-linear (exponential) signal. This signal leads to a non linear 4 to 20 mA / (0)2 to 10 V signal of the gas transmitter.

The Single Point Gas Controller SPC3 is prepared for both types of gas transmitters. The classification of signals is defined in this menu.

Symbol	Description	Setting Status	Function
SP 01	Sensor Point		Selection of SP No.
Linear	SP Signal	Linear	Linear = Transmitter with linear output signal Non linear = Transmitter with non-linear output signal (only AT series from MSR-E)

3.6.5 Threshold / Hysteresis

For each sensor point four alarm thresholds are available for free definition. If the gas concentration is higher than the adjusted alarm threshold, the associated alarm is set. If the gas concentration falls below the alarm threshold inclusive hysteresis the alarm is again reset.

Unused alarm thresholds have to be defined at measuring range end point, in order to avoid false alarms.

At O2 measurement an alarm is released by a decreasing measuring signal!

Symbol	Description	Default Status		Function
SP 01	Sensor Point			Selection SP No.
10 % LEL	Threshold	10 40 40 100 5	Threshold 1 Threshold 2 Threshold 3 Threshold 4 Hysteresis	Gas concentration > Threshold 1 = Alarm 1 Gas concentration > Threshold 2 = Alarm 2 Gas concentration > Threshold 3 = Alarm 3 Gas concentration > Threshold 4 = Alarm 4 Gas concentration < (Threshold X –Hysteresis) = Alarm X OFF

3.6.6 Delay of Alarm ON or OFF

Definition of alarm ON and/or alarm OFF delay. The function applies to all alarms of an SP.

Symbol	Description	Default Status	Function
SP 01	Sensor Point		Selection of SP No.
0 s	Delay Time ON	0	Gas concentration > Threshold: Alarm is only activated at the end of the fixed time (sec.). 0 sec. = No Delay
0 s	Delay Time OFF	0	Gas concentration < Threshold: Alarm is only deactivated at the end of the fixed time (sec.). 0 sec. = No Delay

3.6.7 Control Mode

Definition of the alarm evaluation by means of current (CV) or average value (AV).

Symbol	Description	Default Status t	Function
SP 01	Sensor Point		Selection of SP No.
CV	Evaluation	CV	CV = Control by the current gas value AV = Control by the average gas value

Current- average value function see: 3.7.4

3.6.8 SP Fault Assigned to Alarm

Definition, which alarms are activated in case of a fault at the sensor point.

Symbol	Description	Default Status	Function
SP 01	Sensor Point		Selection of SP No.
Alarm - 1 2 3 4 Fault - 0 0 0 0	Failure SP	0 0 0 0	0 = Alarm not ON at SP failure 1 = Alarm ON at SP failure

3.6.9 Alarm Assigned to Alarm Relay

Each of the 4 alarms can be assigned to any alarm relay. Unused alarms are not assigned to any alarm relay.

Symbol	Description	Default Status	Function
SP 01	Sensor Point		Selection of SP No.
1	A1 A2 A3 A4	01 02 03 04	01 = Alarm 1 activates alarm relay R 01 02 = Alarm 2 activates alarm relay R 02 03 = Alarm 3 activates alarm relay R 03 00 = Alarm 4 doesn't activate any alarm relay

3.6.10 SP Signal Assigned to Analog Output

The sensor point signal can be assigned to the analog output. At this the signal defined in the control mode (current or average value) is transmitted.

Analog output see also: 3.7.7

Symbol	Description	Default Status	Function
SP 01	Sensor Point		Selection of SP No.
0	A	0	0 = SP Signal not assigned to analog output 1 = SP Signal assigned to analog output 1

3.7 Menu System Parameters

Displays and changes the system parameters of the Gas Controller module.

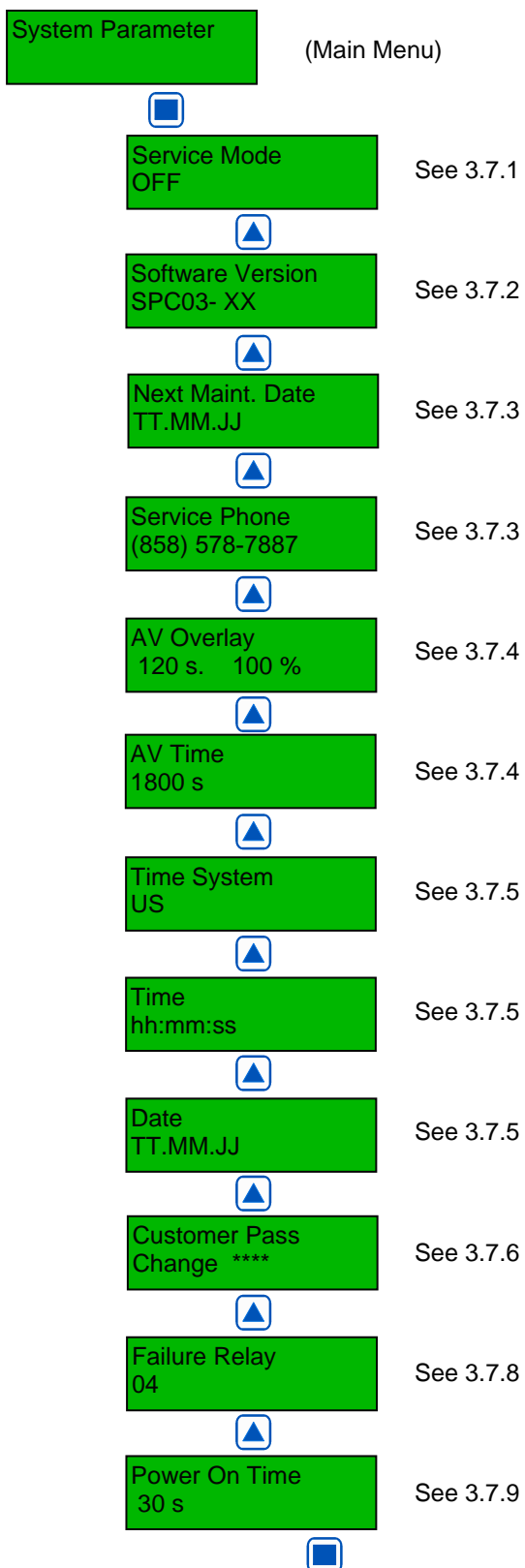

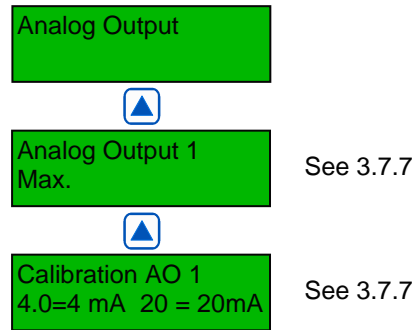

See 3.7.7

See 3.7.7

3.7.1 Service Mode

When the service mode is active (ON) the alarms are not transmitted to the alarm relays (in case of calibration or service work). The service mode is reset automatically after 60 minutes or manually in the menu “Service Mode”.

Symbol	Description	Default Status	Function
Off	Service Mode	Off	Off = Alarms activate the associated alarm relays On = Alarms are not transmitted to the alarm relays

3.7.2 Software Version

Symbol	Description	Default Status	Function
GC03-XX	Software Version		XX = Software Version

3.7.3 Maintenance Concept

Integrated in the SPC3 system there is a control of the maintenance intervals required by law or by the customer. At commissioning or after maintenance the date for the next maintenance is entered. When reaching this date the failure signal is activated the following morning at 9 o'clock, and the phone no. of the service technician occurs in the display. The fault signal (maintenance) can be acknowledged by the operator. The maintenance message (service phone no.) is reset by entering the next maintenance date after having accomplished the maintenance. See also 3.7.5

The service phone no. can be entered individually in the next menu.

Symbol	Description	Default Status	Function
TT.MM.JJ	Maintenance Date		TT.MM.JJ = Input of the date for the next maintenance
0853....	Phone No.		Input of the individual service phone no.

3.7.4 Average Function

For each active sensor point the Single Point Gas Controller calculates the arithmetic average value out of 10 measurements got within the time unit defined in the menu “AV Time”. This average value is indicated in the menu “Measuring Values” next to the current value. At each sensor point the control mode (current or average value) is defined for the alarm evaluation.

The alarm evaluation of the control mode average value is overlaid by the current value, when the current value exceeds the alarm threshold defined in the menu “AV Overlay”. The overlay is delayed by the time factor defined in this menu. Whit time factor 0 sec. the overlay is not active.

Symbol	Description	Default Status	Function
120 s 100 % LEL	AV Overlay	120 s 100 % LEL	sec. = Delay time of average value overlay. % LEL = Alarm threshold of average overlay
1800 s	AV Time	1800 s	sec. = Time for the calculation of the average value

3.7.5 System Time, System Date

Time and date have no memory back up; therefore after each power supply OFF-ON time and date restart.

Input and correction of time and date. Selection of the time and date format.

Symbol	Description	Default Status	Function
US	Time format	US	EU = Display of time and date in EU format US = Display of time and date in US format
hh.mm.ss	Time		hh.mm.ss = Input of the correct time (EU format) hh.mm.ss am = Input of the correct time (US format)
TT.MM.JJ	Date		TT.MM.JJ = Input of the correct date (EU format) MM.TT.JJ = Input of the correct date (US format)

3.7.6 Customer Password (Code 1)

Change the system password for level 1

Symbol	Description	Default Status	Function
1234	Customer Password	1234	1234 = Define the customer's password with 4 characters

3.7.7 Analog Output

The Single Point Gas Controller has one analog output (AO01) with (0)4 to 20 mA / (0)2 to 10 V signal. The signal of SP01 or/and SP02 can be assigned to the analog output. The assignment is effected in the menu "SP Parameters" for each SP. The sensor point sends the signal, which is defined in the menu "C/A Mode".

The output signal (mA / V) and starting point (0 / 20%) is selected at the I/O Board by means of jumper. See fig. 5.

Out of the signals of all assigned sensor points the Single Point Gas Controller determines the minimum, the maximum or the average value and transmits it to the analog output. The definition, which value is transmitted, is effected in the menu "Analog Output 1".

The analog output can be calibrated at 4 and at 20 mA, only in mA mode. Therefore an ampere meter (measuring range 25 mA) can be attached to the AO and the respective factor has to be changed until the analog output corresponds to 4 and/or 20 mA. During calibration evaluation of the sensor point signals is not possible. This calibration is effected by the factory. The factors shall not be changed.

Symbol	Description	Default Status	Function
Max.	Select Output Mode	Max.	Min. = Displays the minimum value of all assigned SP Max. = Displays the maximum value of all assigned SP Average = Displays the average value of all assigned SP
4.0 20.0	Calibration	4.0 20.0	4. = Calibration factor at 4 mA 20.0 = Calibration factor at 20 mA

3.7.8 Define the Failure Relay

Definition of the failure relay. See also fault management (3.1)

Symbol	Description	Default Status	Function
0X	Fault Relay	R04	R0X = Define the fault relay

3.7.9 Power On Time

Gas sensors need a running-in period, until the chemical process of the sensor reaches stable conditions. During this running-in period the current signal can lead to an unwanted releasing of a pseudo alarm. Therefore the power on time is started at the SPC3 after having switched on the power supply. While this time is running out, the Gas Controller does not activate any alarms. The power on status occurs in the starting menu.

Symbol	Description	Default Status	Function
30 s	Power On Time	30 s	XX = Define the power on time (sec.)

4 Mounting / Electrical Connection

The Gas Controller is fixed to the wall through the 4 marked mounting holes at the back side of the housing. These mounting holes are accessible after opening the housing. For mounting you additionally have to plug off the PCB. See fig. 01.

The mounting holes are covered with the enclosed caps after the end of the installation.

We recommend considering the following when choosing the mounting position:

- The installation height depends on the gas type to be detected. For gases whose specific weight is higher than that of air the installation is near the ground. For gases with a specific weight lower than that of air installation has to be at the highest point possible.
- Cables are inserted from below.
- Keep a minimum distance of 150 mm on the right side in order to open the stainless steel housing.
- Customer's instructions.

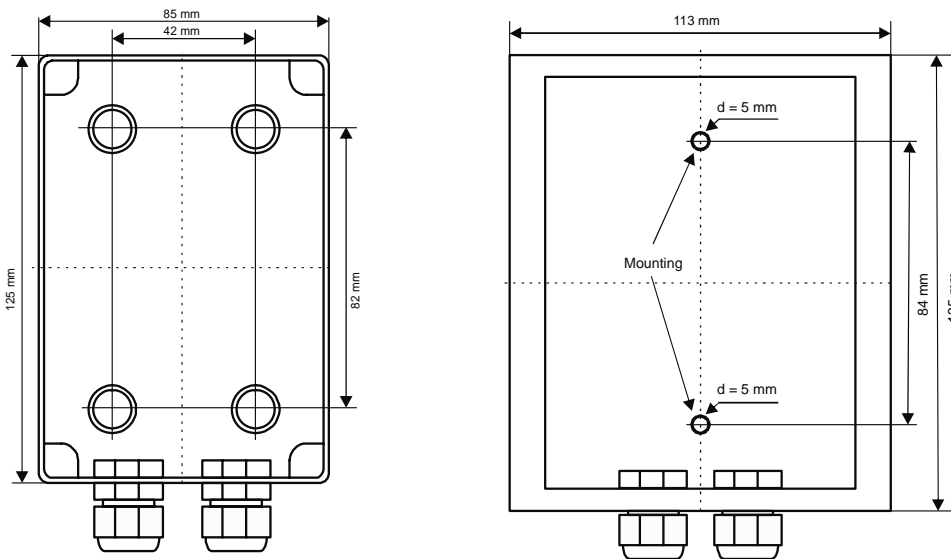

Fig. 01 Standard plastic housing

Stainless steel housing

4.1 Electrical Connection

The technical requirements and regulations for wiring, electrical security, as well as project specific and environmental conditions etc. must be observed when mounting.

The electrical installation may only be completed by a qualified electrician in full compliance with pertinent regulations.

4.2 Connection Diagram

Connection diagram with Option external Transmitter 4 to 20 mA*
Fig. 2

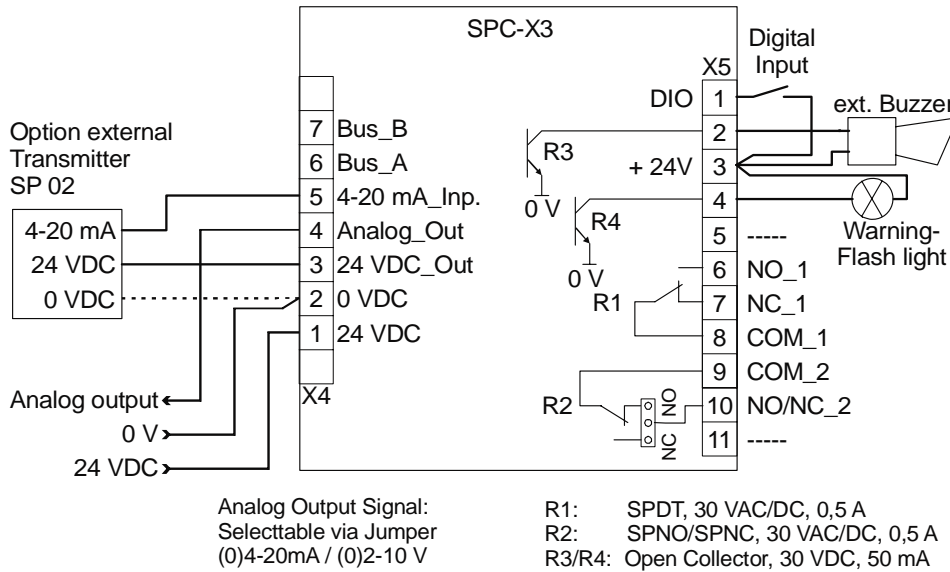

Connection diagram with Option external Transmitter (0) 2 to 10 V*
Fig. 3

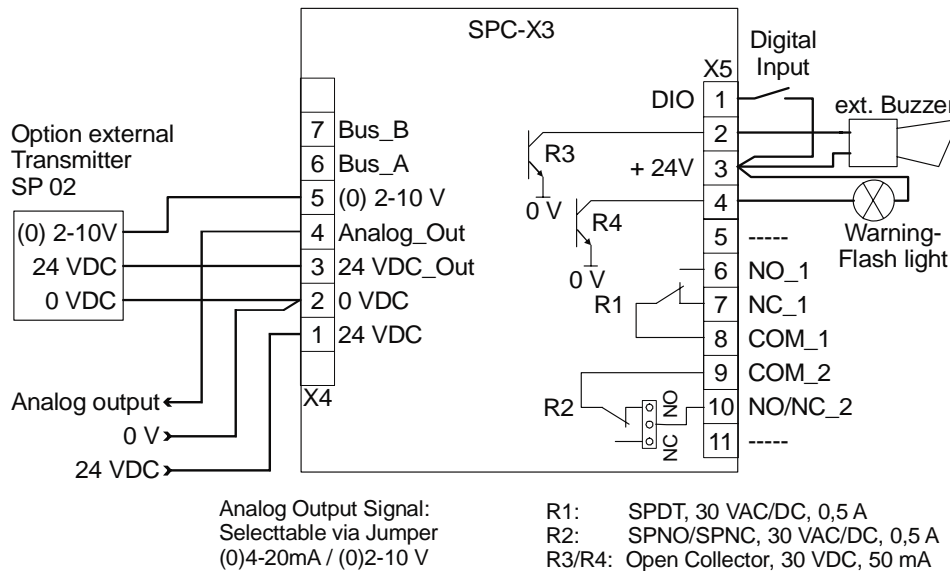

* The analog input function is determined by the hardware. Each PCB has got a label with the specific type.

4.3 Connector Block / Overview SPC3 Module

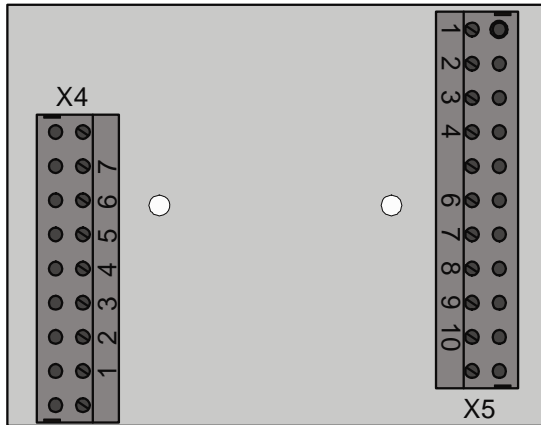

Fig. 4 Selection of the analog output signal

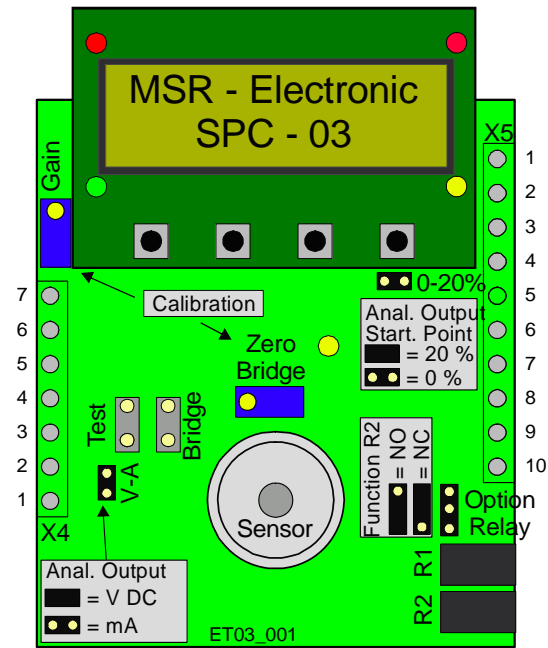

Fig. 5

Jumper 0- 20 %	Jumper V-A	Output signal
Not set	Not set	0 – 20 mA
Set	Not set	4 – 20 mA
Not set	Set	0 – 10 V
Set	Set	2 – 10 V

5 Commissioning

5.1 Commissioning

Prior to commissioning, the wiring of the SPC3 including all field devices must be completely terminated!

Check the optional external transmitter input signal, it has to be the same as indicated on the label of the PCB. See fig. 05

Select the contact for relay 2 with jumper NC/NO. See fig. 2/3 and 5.

Select the analog output signal with jumper V-A and 0-20%. See fig. 5

After switching the power supply “ON” and at the end of the Power ON Time, the SPC3 is ready for use.

The SPC3 is delivered with standard parameters and set points. The registration of the optional external gas transmitter and the assignment of the alarm relays to the individual alarms must always be performed during commissioning. Additionally all other parameters have to be checked and adapted to the local conditions.

The standard parameters can be taken from the following configuration and parameter card. We recommend registering the individual parameters and set points into the list.

We recommend checking the parameters and set points according to the following check list.

5.2 Checklist Commissioning

System Parameter

Parameter	Finished
Time and date	
Parameter of average function	
Password level 1 (customer's password)	
Function analog output	
Define fault relay	
Power ON time	
Service phone no.	
Maintenance date	

Relay Parameter

Parameter	Finished				
	Relay R	1	2	3	4
Relay mode					
Function static / flash					
Latching mode					
Horn function					
External relay operation					
Delay ON time					
Delay OFF time					

SP Parameter

Parameter	Finished		
	SP No. ¹	1	2
SP mode			
Gas type			
Measuring range			
SP signal			
Threshold 1			
Threshold 2			
Threshold 3			
Threshold 4			
Hysteresis			
Delay ON time			
Delay OFF time			
C/A mode			
Assigned failure <> alarm			
Assigned alarm <> alarm relay			
Assig. SP sig. <> analog output			

¹ SP 01 = On Board Sensor, SP 02 = external Transmitter

6 Configuration and Parameter Card

Commission:		Project No.	
Customer:			
Commissioning - Company			
Commissioning - Date		Service Technician	

6.1 Configuration Card of System Parameters

Service	Software Version	Maintenance Date	Service Phone	AV Overlay			Time System	Customer Pass	Power ON Time	Fault Relay
				% LEL	Time	AV Time				
Default	GC 03	06.06.08	858-578-7887	120	120	1800	US	1234	30 s	0

Analog Output 1		
	Calibration	
Mode	= 4	= 20
Max.	4.0	20.0

6.2 Configuration Card of Alarm Relays

Relay No.	Mode	Static Flash	Latching Mode	Horn Function			External		Delay Time	
				Time	Quitt	DI	ON	OFF	ON	OFF
Default	Energized	0 s	No	0	0	0	DI	DI	DI	DI
R01										
R02										
R03										
R04										

6.3 Configuration Card of Measuring Parameters

SP No.	SP Status	Gas Type	Measuring Range	SP Signal	Thresholds				Hyst
					A1	A2	A3	A4	
Default	Not active	Ex	100	Linear	10	20	100	100	5
01									
02									

Delay Time (sec.)		CV/AV	Assigned SP Fault < > Alarm				Assigned Alarm < > Alarm Relay				AO
ON	OFF		A1	A2	A3	A4	A1	A2	A3	A4	
0	0	CV	0	0	0	0	R1	R2	R3	R0	0

7 Specifications SPC3

Electrical	
Power supply	18 – 28 VDC/AC, reverse polarity protected
Power consumption (without options)	120 mA, max. 2,9 VA
Analog output signal Selectable: Current / Voltage : Starting point 0 or 20%	(0) 4 – 20 mA, load ≤ 500 Ω (0) 2 – 10 V, load ≥ 50 kΩ Proportional, overload and short-circuit-proof
Alarm relay (R1)	30 VAC/DC, 0,5 A, potential-free, SPDT
Alarm relay (R2)	30 VAC/DC, 0,5 A, potential-free, SPNO/SPNC
Binary output (R3; R4)	30 VDC, 0,05 A open collector output
Visualization	
Display	Two lines, each 16 characters
Status LED (4)	Normal operation- Fault- Alarm 1- Alarm 2
Operation	4 push- buttons, menu-driven
Operation Environment	
Humidity	15 – 90 % RH non condensing
Working temperature	- 10° C to + 40° C (14 °F to 104 °F)
Storage temperature	5° C to + 30° C (41 °F to 86 °F)
Pressure range	Atmospheric ± 10 %
Physical	
Enclosure stainless steel, type 5	Stainless steel V2A
Colour	Natural, brushed
Dimensions (W x H x D)	113 x 135 x 45 mm (4.48 x 5.35 x 1.8 in.)
Weight	Approx. 0,6 kg (1.32 lbs.)
Protection class	IP 55
Installation	Wall mounting, pillar mounting
Enclosure plastic version, type 0 / 7	Plastics GWPLAST
Colour	RAL 7032 (light grey)
Dimensions type 0 (W x H x D)	87 x 127 x 56 mm (3.43 x 5.0 x 2.2 in.)
Dimensions type 7 (W x H x D)	114 x 156 x 75 mm (4.49 x 6.14 x 2.95 in.)
Weight	Approx. 0,4 kg (0.9 lbs.)
Protection	IP 55
Installation	Wall mounting
Cable entry	Standard 2 x M 20
Wire connection	Screw type terminals min. 0,25 to 2,5 mm ² (14 to 30 AWG)
Guidelines	EMC Guidelines 89/336/EEC CE
Warranty	1 year on material (without sensor)
Options	
Analog input (external transmitter)	
Analog input (1)	4 – 20 mA, input resistance 200 Ω, (0) 2 – 10V, input resistance 25 kΩ, overload- and short-circuit-proof
Power supply for external analog transmitter	24 VDC max. 50 mA
Buzzer	
Acoustic pressure	83 dB (A) (distance 200 mm) (0.7 ft)
Frequency	2300 Hz
Serial Interface	
Transceiver	RS 485 / 19200 Baud
Heating	
Temperature controlled	3 ± 2 °C (38 °F ± 3.6 °F)
Ambient temperature	-20 °C (-4 °F)
Power supply	18 – 20 VDC
Power consumption	0,3 A; 7,5 VA

8 Gas Sensor

8.1 Description

The integrated sensor works according to the catalytic bead principle. The monitored ambient air diffuses through a sintered metal disk in the sensor. Here the explosive gases are burned by catalytic means at a heated detector element (pellistor). The resulting combustion heat also heats up the detector element. This heating changes the resistance of the detector element which is proportional to the partial pressure of the explosive gases.

In addition to the catalytic detector element the sensor also has a similarly heated, inactive compensator element. Both elements are part of a Wheatstone measuring bridge. Environmental influences such as temperature, ambient moisture or thermal conductivity of the monitored ambient air affect both elements to the same extent so that the influences on the measuring signal are almost completely compensated.

The integrated measuring amplifier converts this sensor current into a linear, selective output signal. The measuring amplifier, zero point measuring bridge and the zero point and amplification of the analog output signal are calibrated by potentiometers.

Attention: There is a small quantity of corrosive liquid in the sensor element. If in case of damage persons or objects touch the liquid, you have to clean the affected areas as fast and carefully as possible with tap water. Out of use sensors must be disposed in the same way as batteries.

8.2 Calibration

Required instruments to calibrate the transmitter:

- Test gas bottle with synthetic air or Ex-free ambient air.
- Test gas bottle with Ex gas (methane etc.) in the range of 30 – 60 % of the measuring range.
- Gas pressure regulator with flow meter to control the gas flow to 300 ml/min.
- Calibration adapter with tube (silicone-free, e.g. Viton). Type: Calibr-set-AT3300S01. See fig. 06
- Digital voltmeter with range 0 – 10 VDC, accuracy 1 %
- Small screwdriver.

Note: Please observe proper handling procedures for test gas bottles!

8.2.1 Zero-Point Calibration

Attention: Prior to calibration the sensor has to be powered and fully stabilized for at least 1 hour.

- Connect digital voltmeter to bridge pins "bridge" for zero point calibration.
- Connect the calibration adapter to sensor element.
- Apply sensor element zero calibration gas, 300 ml/min; 1 Bar (14.5 psi) \pm 10%, or other clean air source.
- Wait two minutes until the signal is stable, adjust signal with zero potentiometer "Zero" until the signal is 0 mV \pm 1 mV and stable (= 4 mA).

8.2.2 Gain Calibration

Notes: Ex calibration gas is toxic, never inhale the gas!
 Symptoms: Dizziness, headache and nausea.
 Procedure if exposed: Take the victim into fresh air at once, call a doctor.

- Open window SP 01 in menu “Measuring Value”.
- Connect calibration adapter carefully to the sensor element.
- Apply sensor element span calibration gas (30 - 60 % LEL), 300 ml/min; 1 Bar (14.5 psi) ± 10%.
- Wait two minutes until the measuring value is stable, adjust the value with potentiometer “Gain” until the value corresponds to the calibration gas concentration.
- Remove calibration adapter with a careful light turn. Check the sensor for correct mounting!
- By limiting the gain factor, calibration will not be possible any more when the sensitivity of the sensor reaches a residual sensitivity of 30%. Then the sensor has to be replaces.

8.2.3 Calculation Calibration Gas < >Target Gas (alternative calibration)

$$\ddot{U}_{Gas} = KAL_{Gas} \times (K_{Gas} / \ddot{U}_{Gas})$$

\ddot{U}_{Gas} = Target gas % LEL
 KAL_{Gas} = Calibration gas % LEL
 K_{Gas} = Factor relative sensitivity % LEL calibration gas
 \ddot{U}_{Gas} = Factor relative sensitivity % LEL target gas

Example

Calibration gas	30% LEL Methane
Target gas	Propane
30 % LEL/Methane x (100/63)	47.61 % LEL/Propane

8.3 Cross-sensitivity Data

Gas type	Chemical mark	Sensitivity1 % % LEL/methane	LEL/ % v/v
Acetone	(CH ₃) ₂ CO	50	2.60
Acetylene	C ₂ H ₂	47	2.40
Benzene	C ₆ H ₆	44	1.20
Cyclohexane	C ₆ H ₁₂	44	1.30
Ethyl Alcohol	C ₂ H ₅ OH	64	3.30
Ethyl Acetate	CH ₃ COOC ₂ H ₅	46	2.20
Ethylene	CH ₂	81	2.30
Ethane	C ₂ H ₆	82	3.00
n-Butane	C ₄ H ₁₀	51	1.80
n-Heptane	C ₇ H ₁₆	44	1.05
n-Hexane	C ₆ H ₁₄	46	1.10
Hydrogen	H ₂	107	4.00
Isopropyl Alcohol	(CH ₃) ₂ CHOH	75	2.20
Methane	CH₄	100	4.40 (5.00USA)
Methanol	CH ₃ OH	84	6.70
n-Octane	C ₈ H ₁₈	38	0.95
Propane	C ₃ H ₈	63	2.10
n-Pentane	C ₅ H ₁₂	50	1.40
JP8	-		0.90
JET-A		43	0.70

8.4 Exchange of Sensor Element

Consider static electricity! See point 3.

- Sensor should always be installed without power applied.
- Unplug old sensor element from the PCB.
- Take the new sensor out of the original packing.
- Plug the sensor element into the PCB at X3.
- Make calibration (see 8.)

9 Specification Gas Sensor

Sensor performances	
Gas type	Combustible gases and vapours
Sensor element	Catalytic bead (pellistor)
Measuring range	0 – 100 % LEL
Pressure range	Atmosphere ± 10 %
Storage temperature range	5 °C to 30 °C (41 °F to 86 °F)
Storage time	Max. 6 months
Mounting height	Depending on gas type
Accuracy	± 1 % of reading
Long-term zero drift	± < 5% signal loss/year
Long-term sensitivity drift	± < 2 % measuring range /month
Response time	t ₉₀ ≤ 10s/Methane
Temperature drift	≤ 1 %
Life expectancy	> 3 years/normal operating environment
Humidity range	15 – 95 % RH non condensing
Temperature range	-10 °C to + 40 °C (14 °F to 104 °F)

Calibration adapter

Fig. 6

Type: Calibr-set-AT3300S01



10 Notes and General Information

It is important to read this user manual carefully in order to understand the information and instructions. The PolyGard® SPC3 gas monitoring, control and alarm system may only be used for applications in accordance to the intended use. The appropriate operating and maintenance instructions and recommendations must be followed.

Due to permanent product developments, MSR reserves the right to change specifications without notice. The information contained herein is based on data considered to be accurate. However, no guarantee or warranty is expressed or implied concerning the accuracy of these data.

10.1 Intended Product Application

The PolyGard® SPC3 is designed and manufactured for controlling, for saving energy and keeping OSHA air quality in commercial buildings and manufacturing plants (i.e. detection and automatic exhaust fan control for automotive maintenance facilities, enclosed parking garages, engine repair shops, warehouses with forklifts, fire stations, tunnels, etc.).

10.2 Installers` Responsibilities

It is the installer's responsibility to ensure that all PolyGard® SPC3 are installed in compliance with all national and local regulations and OSHA requirements. All installations shall be executed only by technicians familiar with proper installation techniques and with codes, standards and proper safety procedures for control installations and the latest edition of the National Electrical Code (ANSI/NFPA70). It is also essential to follow strictly all instructions as provided in the user manual.

10.3 Maintenance

We recommended checking the PolyGard® SPC3 system regularly. Due to regular maintenance differences in efficiency can easily be corrected. Limited Warranty Re-calibration and part replacement may be implemented in the field by a qualified technician and with the appropriate tools. Alternatively, the easily removable plug-in transmitter card with the sensor may be returned for service to INTEC Wilson Mohr.

10.4 Limited Warranty

MSR warrants the PolyGard® SPC3 against defects in material or workmanship for a period of one (1) year beginning from the date of shipment. Should any evidence of defects in material or workmanship occur during the warranty period, MSR will repair or replace the product at their own discretion, without charge.

This warranty does not apply to units that have been altered, had attempted repair, or been subjected to abuse, accidental or otherwise. The above warranty is in lieu of all other express warranties, obligations or liabilities.

This warranty applies only to the PolyGard® SPC3. MSR shall not be liable for any incidental or consequential damages arising out of or related to the use of the PolyGard® SPC3.