

# Air & Gas Pressure Switches

Specifications subject to change without notice. | USA 200204 | Page 1 of 2



DBL

## DESCRIPTION

Adjustable vacuum, pressure, and differential pressure switches for air and other non-combustible, non-aggressive gases.

## APPLICATION

Air pressure control and monitoring of ducts, filters, fans and other devices in ventilation and air conditioning systems.

## FEATURES

- Setpoint can be adjusted without field gauge reading
- Compact & easy to install
- High accuracy & life cycles
- Adjustable switching differential
- Calibrated, scaled setpoint knob



certified  
ISO 9001



## SPECIFICATIONS

<b>Type of operation</b>	On/Off, single-stage, micro switch
<b>Output</b>	1 SPDT, 250 VAC, 1.0 (0.4) A
<b>Trip/setpoint</b>	Internal linearly scaled knob
<b>Switching differential</b>	Screw adjustable
<b>Sensing techniques</b>	2 pressure chambers separated by diaphragm
<b>Diaphragm material</b>	Silicone
<b>Life cycles</b>	1,000,000
<b>Permissible ambient temperature</b>	
- working/storage	-4°F to 185°F (-20°C to 85°C)
<b>Wire</b>	
- connection	Spade
- size	Maximum 16 AWG (1.5 mm <sup>2</sup> )
<b>Cable entry</b>	1/2" NPT conduit connection
<b>Housing</b>	
- material	Base = PA 6.6, Cover = Polystyrene
- color	Transparent
- protection	NEMA 3 (IP54)
- dimensions (diameter)	4.0 x 2.3 in. (100 x 58 mm)

<b>Installation</b>	Surface mounted
<b>Pressure port connection</b>	2 for PVC tube, P1 (+) and P2 (-)
- diameter	0.236" (6 mm) for O.D. 3/16" (8 mm) push-on tubing
<b>Ship weight</b>	0.4 lb (0.2 kg)
<b>Warranty</b>	Two years material and workmanship

## WIRING CONFIGURATION

DBL

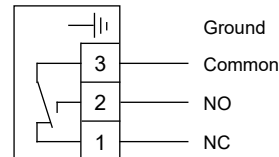

Pressure increase, contact connection: 3 to 2  
Pressure decrease, contact connection: 3 to 1

Pressure port P<sup>1</sup> (+) = high pressure

Pressure port P<sup>2</sup> (-) = low pressure

Adj. Setpoint Range* Inch WC (Pa)	Adj. Switching Diff.** Inch WC (Pa)	Max. Operation Pressure Inch WC (kPa)	Scale Type	Part Number
0.08 to 0.8 (20 to 200)	0.04* to 0.08 (10 to 20)	40(10)	930.80	DBL-205L
0.20 to 2.0 (50 to 500)	0.08* to 0.16 (20 to 40)	40(10)	930.83	DBL-205B
0.80 to 4.0 (200 to 1000)	0.40* to 0.80 (100 to 200)	40(10)	930.85	DBL-205D
2.0 to 10.0 (500 to 2500)	0.60* to 1.20 (150 to 300)	40(10)	930.86	DBL-205E
Kit: (2) Metal Right-Angle Pitots, (2) Grommets, 6.5 ft (2.0 m) Tubing				DBZ-06
Kit: (2) Plastic Straight Pitots, (4) Mounting Screws, 6.5 ft (2.0 m) Tubing				DBZ-07

\* The adjustable trip/setpoint within the control range is calibrated for vertical mounting position pressure, port connection pointing downwards. If mounted in horizontal position, deduct 0.08 inch WC (20 Pa) from desired setpoint for off-set adjustment. If setpoint at the bottom of range, do not mount DBL in horizontal position.

\*\* Factory set switching differential is ± 15% of trip/setpoint.

**DIMENSIONS**

inches (mm)

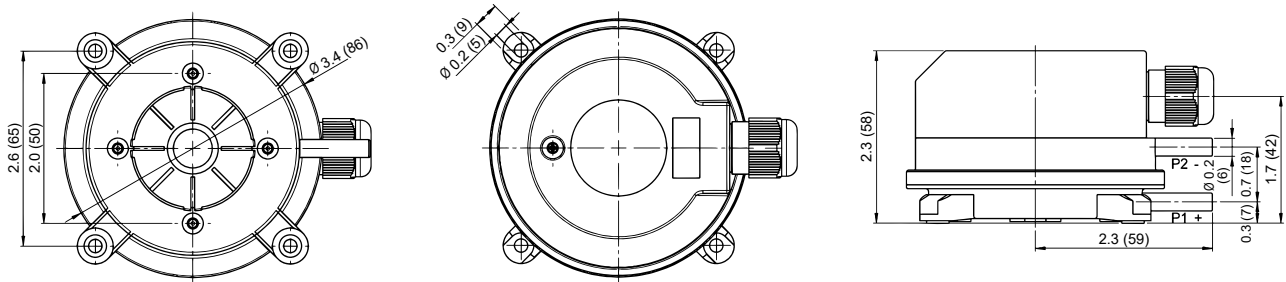

**INSTALLATION**

**Mounting position**

Mounting the switch in the vertical position, with the pressure port connection pointing downwards (figure 1).

If mounted in horizontal position, deduct 0.08 inch WC (20 Pa) from desired setpoint for offset adjustment. If the setpoint is at the bottom of the range, do not mount the pressure switch in the horizontal position. Never install the switch where the setpoint knob faces downward. This will cause incorrect switch performance.

**Surface mounting**

Mount with four screws through bracket (figure 2). Do not tighten the screws excessively. It could deform the pressure switch and lead to air leakage.

**Duct air pick-up**

To insure good airflow to the pressure switch, it is suggested to use the tubing and pitot kit DBZ-06 or DBZ-07 (figure 3).

**Pressure port connections**

Pressure port P1 (+) = high pressure, it is located on the lower part of the housing base. Pressure port P2 (-) = low pressure, it is located on the upper part of the housing base (figure 4).

**Electrical connection and switching function**

Electrical wiring connections must be done per local building and electrical codes.

The DBL data sheet will provide all appropriate data for the control relay and output switching.

**Control settings**

Do not adjust the setpoint knob or screw adjustment for the switching differential (figure 5) when high voltage power is connected to the pressure switch. For setpoint setup and switching differential data, refer to DBL data sheet.

**Housing cover installation**

Mount housing cover (figure 6) prior to operating the pressure switch.

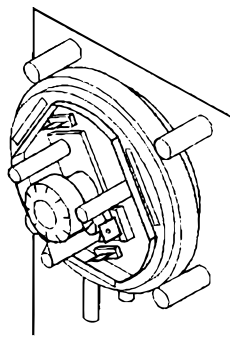

Figure 1

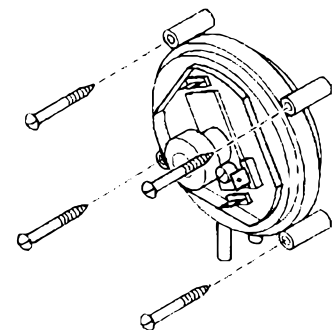

Figure 2

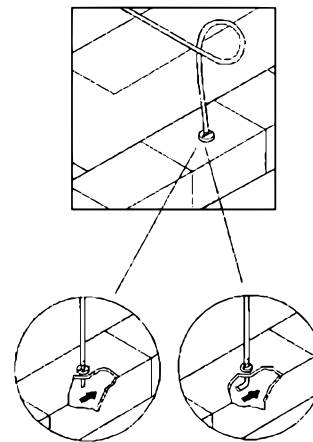

Figure 3

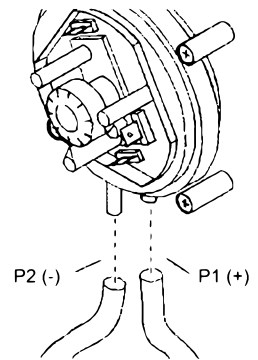

Figure 4

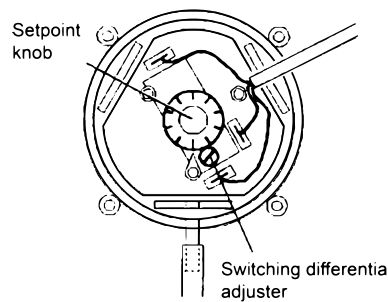

Figure 5

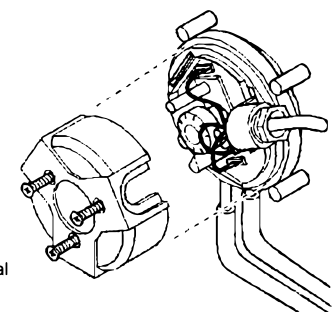

Figure 6